

SKY-POWER FACTS vs. SKY-POWER FANCIES See page 6

FICTION
MODEL
BUILDING
FACT

APRIL
15¢

FLYING ACES



IF THE "NEW CAESAR" RAIDS "CARTHAGE"

AUGUST SENOMBURG

"ATTACK FORMATIONS ARE TICKLISH!"--NOTES ON YOUTH AIR MOVEMENT
DICK KNIGHT MYSTERY, PHINEAS FUN FEST, "COFFIN" KIRK AND TANK
MODELS: CURTISS XP-40, HUTTER SAILPLANE, TWO GAS JOB ARTICLES

MEGOW'S PIPER CUB

Gas-Powered!



PLANE-FILM The Magic Covering

Megow's are now exclusive distributors of this marvelous light, tough, elastic covering for model planes.

Non-porous, smooth as glass, PLANE-FILM can be applied in a fraction of the time required by old methods. Actually stretches itself drumlike over irregular curves . . . easy to get even tension on surface areas, even distribution of weight and perfect balance so necessary to good performance. PLANE-FILM comes attached to backing sheet—it is easy to handle and cut to shape. Stripped from backing, it is soft and pliable, and forms to the many curves necessary in model building.

PLANE-FILM eliminates the use of glue, dope, finishes and stretching, is far superior in lasting quality and produces an opaque brilliant, colorful, glassy effect that cannot be approached by old methods.

**COLORS: Red, Blue, Silver, Yellow
White, Black**

Retail Prices

Per Sq. Yard, \$1.50 (plus 30c Solvent & Postage)			
36" x 18"80	"	25c	" " " "
18" x 18"45	"	20c	" " " "
18" x 12"32	"	15c	" " " "
12" x 12"23	"	10c	" " " "
9" x 12"18	"	10c	" " " "

SOLVENT

½ oz. bottle 5c 1 oz. bottle 10c

MEGOW'S AIRCRAFT DOPE



Superior quality same as used on big planes. Brilliant, rich colors, smooth-flowing, quickly drying. Dense colors, can be thinned 50% and still give excellent coverage. Fine for spraying. Sizes from 5c up. Send for color card.

with the New READY-CARVED Leading Edge!

Experienced model builders know that Megow models can be built in a fraction of the time required for other kits. For instance, note the time-saving exclusive Megow Ready-Carved Leading Edge used on this new Piper Cub! Among other time-savers that help you produce expert jobs, remember that Megow plans are large, clear and easy to follow—that they have been thoroughly engineered and tested—and that Megow kits contain only complete materials of the very highest quality.

The PIPER CUB gas-powered model just introduced, is one of the new, small size, light-weight class that avoids crackups and is so easy to carry in a car and put into flight.

The latest and best in construction ideas, and the most practical in size. Features new ready-shaped Leading and Trailing Edge. Scale spacing of struts and ribs in wings and fuselage. Wingspan 52¾".

\$3.95
plus
20c post.

Bassett's Gas-Powered CARDINAL



Designed by Maxwell Bassett, nationally known builder and champion flier of gas models. Very latest ideas in gas model engineering. 48" wingspan, light, crackup-proof. Ready-to-use propeller, metal parts die-cut. Special rubber wheels. Uses any small ¾" stroke and bore motor.

CARDINAL
\$3.95 plus 20c post.

World-Famous GAS-POWERED QUAKER FLASH

Easy to transport—wings removable, landing gear folds back. Uses any model airplane motor. Motor accessible, easily removed. 3½" puncture-proof rubber wheels. Large plans and photos, all materials. Span 67". Length 47".



QUAKER FLASH
\$4.95 plus 20c post.

GIANT 50" FLYING MODELS

Amaze your friends with the MOTOR-HUM, long flights and flat glides of one of these big, beautiful outline scale models. Light-weight, strong construction, expert engineering, with designs and plans so large and clear that building is easy. In addition to the TAYLOR CUB shown here, there's a WACO at \$2.00; a 60" STINSON at \$1.50; MONOCOUE, \$1.25; FAIRCHILD RANGER, \$1.00 and AERONCA, \$1.00. By mail, 15c additional.



TAYLOR CUB, \$1.00 plus 15c post.

Send 5c postage
for 100-page
illustrated
CATALOG!



MEGOW'S MODELS

Dept. FA, Howard and Oxford Streets, Philadelphia, Pa.
or 217 N. Desplaines Street, Chicago, Ill.
or Great Western Merc. Co., 718 Mission St., San Francisco

S. Guiterman & Co., Ltd., London, Eng. Aer-O-Kits, Sheffield, Eng.
A. Warnaar, Voorburg, Hol. American Products, Tienen-Tirlemont,
Belg. Eskader, Stockholm, Sweden. K-Dee Pty., Ltd., Sydney, Aus.

Please send me

- | | | |
|---------------------------------------|---|--------------------------------------|
| <input type="checkbox"/> PIPER CUB | <input type="checkbox"/> ARROW SPORT | <input type="checkbox"/> WACO |
| <input type="checkbox"/> CARDINAL | <input type="checkbox"/> TAYLOR CUB | <input type="checkbox"/> HOWARD DGA8 |
| <input type="checkbox"/> QUAKER FLASH | <input type="checkbox"/> AERONCA K | <input type="checkbox"/> CESSNA C-34 |
| <input type="checkbox"/> REARWIN | <input type="checkbox"/> FAIRCHILD RANGER | <input type="checkbox"/> RYAN SC |
| <input type="checkbox"/> MONOCOUE | <input type="checkbox"/> STINSON RELIANT | <input type="checkbox"/> GULFHAWK |
- Money Order for \$_____ is enclosed. CATALOG

Name _____

Address _____

City _____ State _____

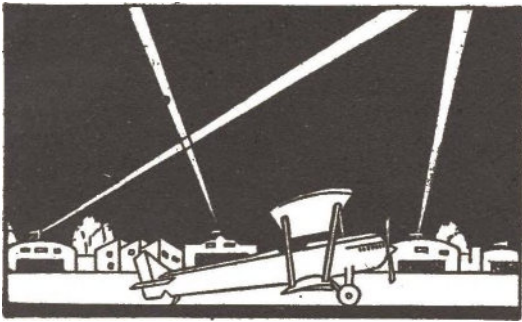

DO YOU KNOW—

What America's real air strength is today?
Turn to page 6

Why a lot of air-minded non-college men are peeved at the sky training set-up?
Turn to page 22

How our civilian aero program should be safeguarded?
Turn to page 25

FLYING ACES

A. A. WYN, Publisher

HERB POWELL, Editor

VOLUME XXXII

APRIL, 1939

NUMBER 1

ON OUR FACT AND FICTION RUNWAY

TRIP-SIX TRAP	DONALD E. KEYHOE	2
Dick Knight saw a stark face—which in the next instant became a grinning skull!		
SKY-POWER FACTS vs. SKY-POWER FANCIES	DAVID MARTIN	6
Straight-from-the-shoulder dope on the aero questions of the hour.		
SLAKED LIMEYS	JOE ARCHIBALD	10
Phineas strains the lesson before the Tommies can lessen the strain.		
"ATTACK FORMATIONS ARE TICKLISH!"	FRANK LAMBERT	14
Cutting it fine was the regular fare—until Fluger cut it finer than that!		
IF THE "NEW CAESAR" RAIDS "CARTHAGE"		17
How Roman Legions may again storm the historic stronghold. The story of our cover		
THE CLUE OF THE BRED A BROOD	ARCH WHITEHOUSE	18
"Coffin" Kirk banished from the air! And "Tank" swallowed by the "green hell"!		
THROUGH THE AERO LENS		21
Our latest batch of newsy sky photos.		

MODEL MAKERS' SECTION

WITH THE MODEL BUILDERS			33
FLYING-SCALE SCOOP—THE CURTISS XP-40!	J. DAVIDSON		34
BUILD THE HUTTER H-17 SAILPLANE.	NICK LIMBER		40
NEWS OF THE MODEL BUILDERS			44
HERE'S THE BELLANCA SOLD TO CHINA!	M. ABZUG		45
GAS JOB KNEE ACTION	REEVES & STEIGERWALT		46
SELECT THE CORRECT ENGINE	SHERESHAU & ZECCHITELLA		48
FROM THE MODEL BUILDER'S WORKBENCH			50
WHAT DO YOU SAY?			50
THE WARTIME JUNKERS J.I	CHARLES EATON, JR.		52

DEPARTMENTS AND FEATURES

THEY HAD WHAT IT TAKES	5	THE AIRMAIL PALS	26
SNAPSHOTS OF THE WAR	13	WISECRACK-UPS	27
ON THE LIGHT PLANE TARMAC	22	MODERN PLANES ALBUM	28
ALL QUESTIONS ANSWERED	24	FLYING ACES CLUB NEWS	30
NOW WE'LL ASK YOU A FEW	24	JOIN THE FLYING ACES CLUB	32
HAPPY LANDINGS	25	IN OUR NEXT ISSUE	55

Cover Painting by August Schomburg

Published monthly by Magazine Publishers, Inc.; office of publication, 29 Worthington St., Springfield, Mass. A. A. Wyn, President. Editorial and executive offices, 67 W. 44th St., New York. Entered as second-class matter, Nov. 14, 1928, at Springfield, Mass., under Act of March 3, 1879. Title registered in U. S. Patent Office. Copyright, 1939 by Magazine Publishers, Inc. Nothing may be reprinted without permission of the publishers. Manuscripts will be handled with care, but this magazine assumes no responsibility for their safety. For advertising rates address FLYING ACES Magazine, 67 W. 44th St., New York City. Subscription rate: \$1.50 for twelve issues in the United States and possessions; \$2.00 in Canada; and \$2.50 in all other foreign countries. Single copies, fifteen cents.

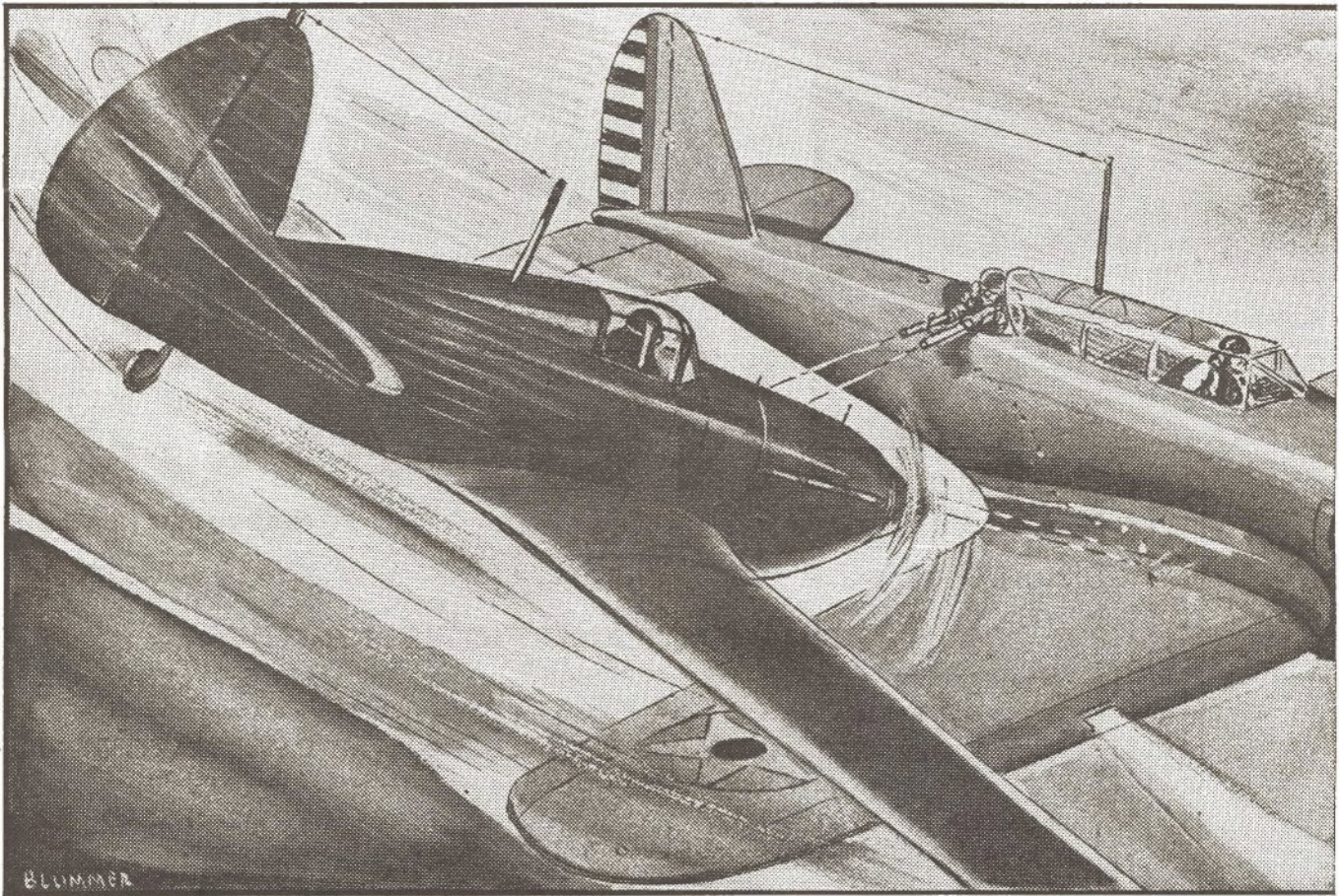

Trip-Six Trap

* * *

By Donald E. Keyhoe

Author of "Raid of the Wraith," "Guns Over Gatun," etc.

Illustrated by Jon L. Blummer

* * *

CHAPTER I

THE BLACK GHOST

FOR almost five minutes, the man from Tia Juana stood furtively watching the Air Corps fighters lined up on Lindbergh Field. The chartered car which had brought him at high speed to San Diego had already departed. But still he made no motion to enter the airport office, though the northbound plane was nearly ready for loading.

A moment longer, he remained back in the shadows, eyes narrowed behind his tinted glasses. The Army ships were Sevversky P-35's, and he could dimly see the muzzles of Browning guns protruding from their cowls. That in itself was peculiar—Air Corps fighters with mounted guns were seldom seen except in maneuvers or target practice. And their presence at a commercial airport only added to the mystery. There were six of the P-35's, and back by the first hangar he glimpsed an equal number of pilots. One of the ships had just been

warmed up. As the unseen man watched, a mechanic switched off the motor and crawled out, and down the line a second mechanic started the engine of another P-35.

The look of suspicion slowly died out of the man's eyes. Whatever the reason for this strange activity, it could hardly be connected with him. No one but himself knew that Richard Knight, fugitive secret agent, was in that part of the world. No one knew it save Doyle, his former co-agent, whose almost frantic code message had brought him hurrying across the border—even though it meant risking arrest.

Reminded of the need for haste, Knight turned from his intent regard of the Army ships and entered the waiting-room. As he passed the newsstand, headlines of an evening paper leaped up at him:

SECOND MYSTERY AIR CRASH

He stopped, the brim of his slouch hat turned down over his eyes, and quickly purchased a paper. There was no time now to read the story, so he shoved the paper into his coat pocket and hurried to the ticket office. His face, tanned to a mahogany, showed no trace of nervousness. But in spite of his grim self-control his pulses began to pound. At any large airport, there was a chance of running into some one who might recognize him, in spite of his attempts to alter his appearance. Complicated disguises had never appealed to him, except when there was no other way. He was relying now on the tint of his beribboned glasses to make his dark-blue eyes seem black, and to combine with his deep tan and black

RICHARD KNIGHT FACES THE FLYING PHANTOM!

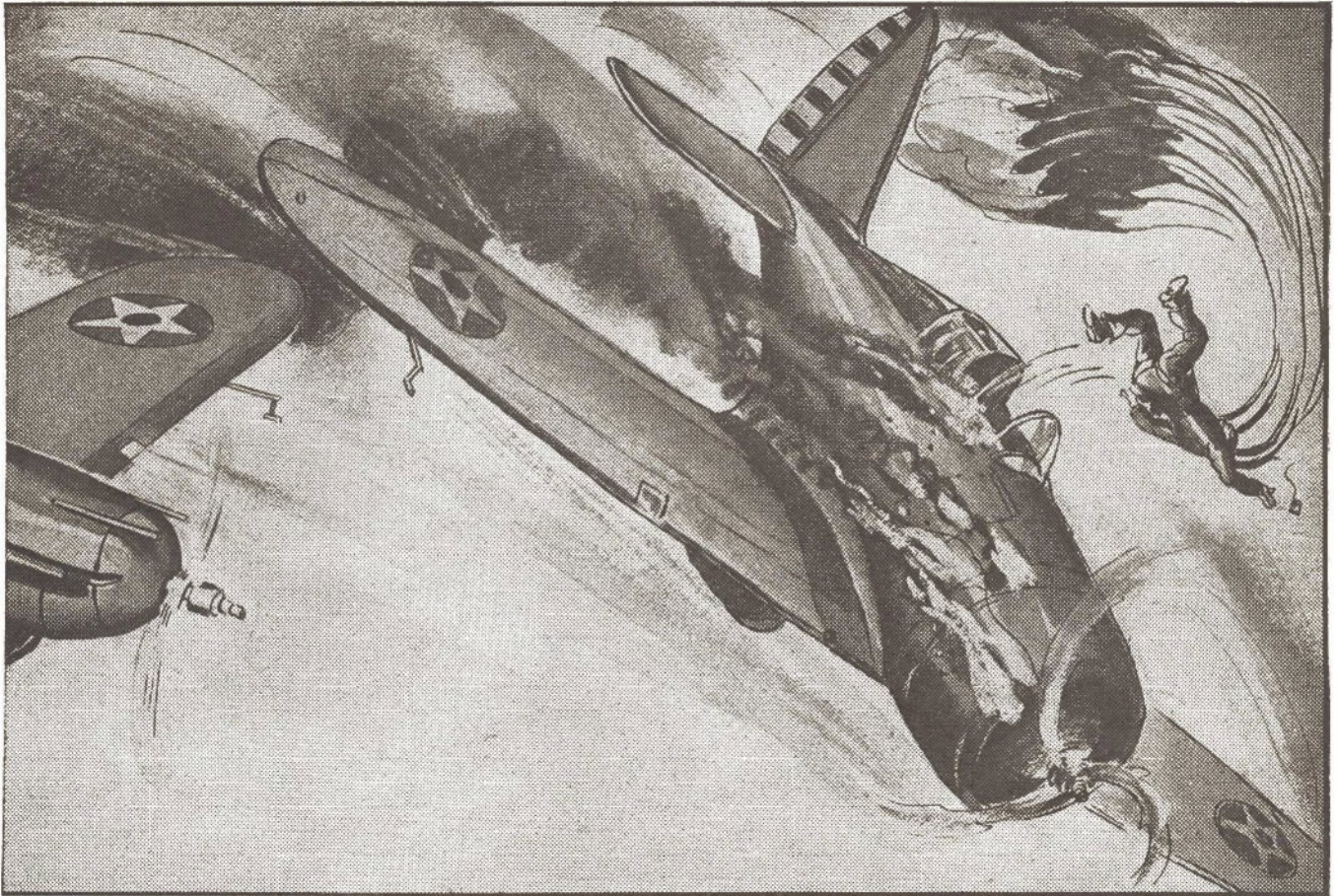

Hardly had the Austrian's flailing figure been wrenched from the pit of the blazing P-35 when the Consolidated shook under a deadly stitching of vengeful lead. The darting ebon devil was upon them!

hair to give him a foreign look at a casual glance.

"One to Los Angeles, *señor*," he told the man behind the counter. "I wish to take the plane leaving at nine-fifty."

"Sorry, the Coast Airline ship is all filled," said the ticket-man laconically. "Reservations sold out early this morning."

Knight fingered the flowing ribbon of his glasses.

"That is unusual, no?" he said. "Especially after this so bad news?"

He tapped the paper protruding from his pocket. The other man looked at him oddly.

"There's a lot of unusual things going on, mister, and that's not the half of it."

"I could, perhaps, hire a small plane?" Knight said anxiously. "It is imperative that I reach Los Angeles as soon as possible."

"All but scheduled flights and Service ships are grounded—by order of the C.A. A.," replied the ticket-man. "Afraid you'll have to take a bus or a train this time."

KNIGHT turned away, went swiftly to the door that lead to the loading space. He emerged in time to catch the muttered words of two Air Corps pilots who were approaching the building.

"—some crazy hoax," the first man said. "A body *couldn't* burn that fast."

"I tell you the General himself saw it," retorted the other officer. Then he checked himself abruptly as he saw Knight. Thereupon the two disappeared within the airport building.

The tall secret agent gazed after them curiously, then turned and strode toward the parking space for cars. But as soon as he was out of the brighter lights he halted, slipping one hand inside his coat. A mirthless smile twitched the corners of his lips as he stole toward the hangars. A sardonic Fate had already marked him as a traitor, and every effort to prove his innocence had only added to the ugly charges against him. What he planned to do now would make small difference in that sinister list.

The second P-35 from the end of the line was idling, and the other one, which had been warmed up, was being started again. Mechanics were at the controls, and Knight hazarded a guess that the pilots he had encountered were going in for some last-minute instructions. He crept toward the nearer ship, hoping to reach it before the floodlights went on for the northbound ship's take-off. He was within twenty feet of the fighter when one of the men down the line saw him and came dashing toward the ship. Knight leaped to the cockpit, thrust his suddenly drawn .38 against the startled mechanic's head.

"Jump! And make it fast!"

The man all but fell out of the ship. Knight whirled, drove a sharp left hook to the jaw of the second mechanic, who was almost upon him. The Army man fell, and in a flash Knight was in the Seversky's cockpit. He jammed the right rudder pedal hard down, gripped the throttle. The motor revved up with a roar, and the fighter's wheels crabbed free of the chocks. The red flash of a pistol cut the shadows, and another gun blazed as two Army

First, a plane crash in Chicago—then a second disaster in Seattle, 2,000 miles away! Was there some sinister, devilish relation between them? That question burned in the mind of Richard Knight, fugitive agent. But now a Coast Airline DC-3—the very ship he himself had attempted to board—was diving past his speeding Seversky. And at one of its windows, a stark white face was pressed against the glass—a gaunt visage which in the next instant became a grinning skull!

pilots came racing from the hangar. A bullet drilled through the Plexiglass enclosure. Knight bent low, sent the fighter thundering out onto the airport, past a DC-3 which was being loaded. A red light blinked furiously from the tower, and floodlights went on with a sudden bright glare.

THE P-35 shot down the cleared runway, lifted swiftly. Knight cast a hasty glance backward as he retracted the landing gears. The other Seversky which had been warmed up was streaking after him, and still others were hurriedly being started. The fugitive agent whirled his stolen ship into a sudden split-turn that brought him back across the airport at less than fifty feet from the ground. For an instant he thought he had shaken off the Army pilot. But with a tight reversal the other Seversky now plunged in after him.

Tracers smoked over his head, yellowish in the glare. Knight nosed down, and the bellowing P-35 seemed on the point of piling headlong into a hangar. There was a second when the fitting tracers ceased, and with a lightning jerk at the stick Knight hurled the fighter into a vertical zoom. Rolling out, he raced across the tip of Coronada and on above the dark Pacific. With the Army pilot shaken off, he held his course out to sea for several minutes, then swung in a gradual curve back to the north, climbing steeply.

There was a radio in the Seversky's cockpit. Knight turned it on, listened on several settings. He caught the routine weather broadcasts, airline dispatches, and plane-to-ground reports along the Coast and nearby areas. But there was as yet no mention of the stoler ship.

He smiled dryly as he switched off the set. G-2 was evidently keeping it off the air, spreading its dragnet by ground wires to avoid tipping him off. They would probably suspect that he was some foreign spy making off with the Army ship to deliver it and its secrets to other spies below the border. In that case he might be able to reach Los Angeles, land at some outlying spot, and still keep his appointment with Doyle.

"If humanly possible, be at Griffith's Park airport before midnight tonight," the Irishman's code had read.

Knight had caught it on a special high-frequency set in the Sikorsky Clipper that had been his shifting base ever since the disastrous affair of the Four Faces. Though he had wrecked the plans of that far-flung criminal empire to seize vital American defense secrets, a dying traitor had condemned him with his last words, and he had been forced to flee in the luxurious amphibian which the Four Faces had used as their flying headquarters. Tonight, the Sikorsky lay securely hidden in Mexico, as near the border as he dared bring it. It would have been suicide to fly that ship back into the States.

"—be at Griffith's Park airport before midnight."

The words ran through his brain again, and on an impulse he reached into his pocket and took out the newspaper. Switching on the cockpit light, he scanned the headlined story:

Twenty-five persons were killed today in a second mysterious airline crash when a Skylounge of the Rocky Mountain Airlines plummeted headlong into the heart of Seattle, causing a disastrous explosion and fire. By a coincidence, this second airliner to crash within forty-eight hours also struck an aircraft plant, causing damage estimated in the millions, with at least a hundred new fighting planes destroyed.

A bizarre element was injected into the mystery when it was reported that Captain J. S. McNeill, the senior pilot

of the ill-fated airliner, sent out a wild plea for help just before the crash. Two amateur operators stated that McNeill screamed something about a "Black Ghost" in the middle of a regular report that he was preparing to land. This, however, has not been confirmed either by the Civil Aeronautics Authority or airline officials.

The Skylounge was within a few miles of the Seattle airport when it hurtled to the ground, engines still at full speed. Four night watchmen at the Braden Aircraft Plant were killed in the explosion. They were cremated, along with all on board the plane, in the resulting fire. Pending investigations, further details are being withheld

Knight stared at the paper, skipped over the list of the dead, and read another reference to the first crash:

This second disaster, closely parallels the crash at Chicago, two nights ago, when a sleeper-plane of Central Sky-lines dived into a hangar of the Barnes Aircraft and Engine Works and set off an explosion and fire which almost completely demolished the plant. The veil of secrecy thrown about this first case lends weight to an earlier theory of sabotage on board the airliner.

There were several columns more, including descriptions of both crashes by eye-witnesses and theories by various experts. Mechanically flying his course to Los Angeles, Knight read every word. He had kept well out to sea, to avoid being reported by observers who might hear his engine, and this course had added thirty miles to the straight airline distance to Los Angeles.

He was still puzzling over the two mystery crashes when he passed over Long Beach. From his altitude of 8,000 ft., the light of the city were obscured in clouds, but he could check his position by cross-bearings on the San Pedro and Los Angeles radio stations.

HE STARTED DOWN in a long glide, throttle cracked. The easiest course was to attempt a quiet landing at Griffith's Park, keeping in readiness for a swift take-off if necessary. He might even be able to land at the comparatively unused National Guard field without having his stolen ship spotted at once.

Knight turned on the radio again to tune in the range-beacon at Burbank and offset his course for Griffith's Park. As he turned the dial he heard a tense voice come through:

" . . . Trip Six . . . Leonard, Trip Six, to Burbank! Clear me in! Escort ships both missing . . . can't wait for procedure—"

Knight sat up tautly. Trip Six was the DC-3 from San Diego—the ship he had intended taking to Los Angeles. Instinctively, he opened the throttle and nosed down to reach Trip Six's altitude for approaching Burbank. The Seversky droned down through a misty darkness only slightly decreasing as the glow of Los Angeles became perceptible ahead.

The fighter was down to 5,000 ft. when a furious current of air struck its wings and threw it into a slip. Knight battled the stick as the P-35 shook in the turbulent air. There was another violent bump, then a freezing sensation went up his spine. *Something* had whirled by his wingtips—something that was only a weird black blur. He snapped on the landing-lights, but the misty sky mocked him with its emptiness. As he stared around him, the voice of the Burbank operator rattled into his earphones:

"Burbank to Leonard, Trip Six! What's happened? Why don't you answer?"

The last word was hardly finished when a frenzied cry came over the air:

"The Thing! It's got me—the Black Ghost!"

The voice of Trip Six's pilot rose in a bloodcurdling shriek—then broke in a horrible silence. Knight dived at full-gun out of the clouds, saw the red and green lights of the airliner less than half a mile away. As he raced after it, the DC-3 pulled up in a sharp, crooked, zoom, then pitched down steeply, as though desperate hands fought the controls.

(Continued on page 56)



They Had What It Takes

XXVII—C. P. T. ULM—GREAT AUSSIE PIONEER

By ALDEN McWILLIAMS



1—Born in Australia in 1892, Charles Phillippe Thomas Ulm differed from most other sky pioneers in that he did not turn to flying until he had reached the age of 27. It was in 1919 that the great possibilities of aviation in the "Down-Under" country inspired him to learn to fly. Then he immediately planned to develop an Australian air system.

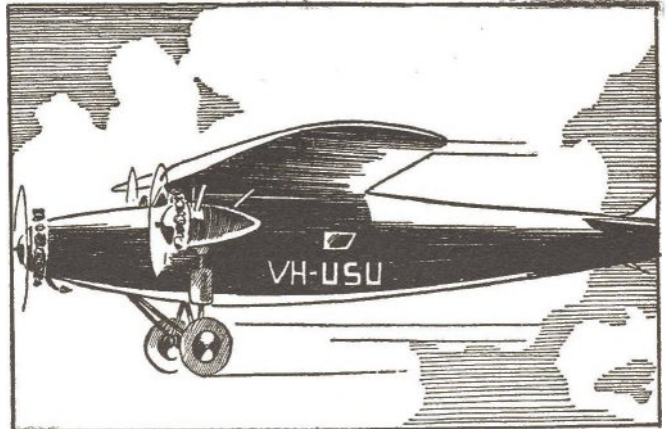

2—Ulm later became associated with the renowned Kingsford-Smith, and together they formed the Australian National Airways. Striking flights around the great continent followed. Then in June 1928, Ulm accompanied Kingsford-Smith when the latter flew the Fokker *Southern Cross* in the first astounding trans-Pacific flight from San Francisco to Sydney.

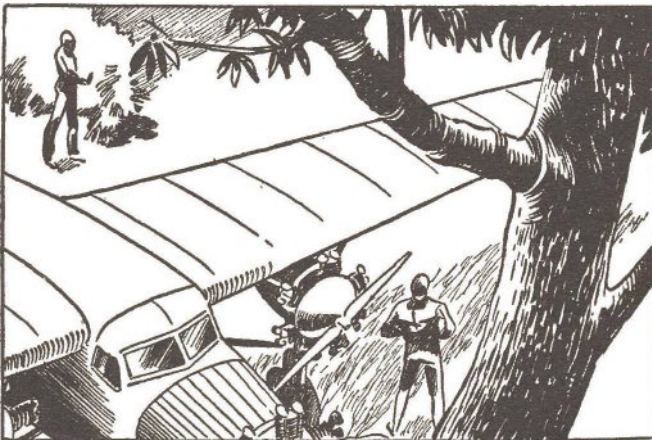

3—After an efficient round-trip sky run to New Zealand, Ulm and Smith took off in 1929 to make a fast journey from their home-land to England. Unfortunately, they were forced down in Australia's Northern Territory and stranded for 12 days before being rescued. Despite this set-back, however, they flew on to Britain in 13-days' flying time.

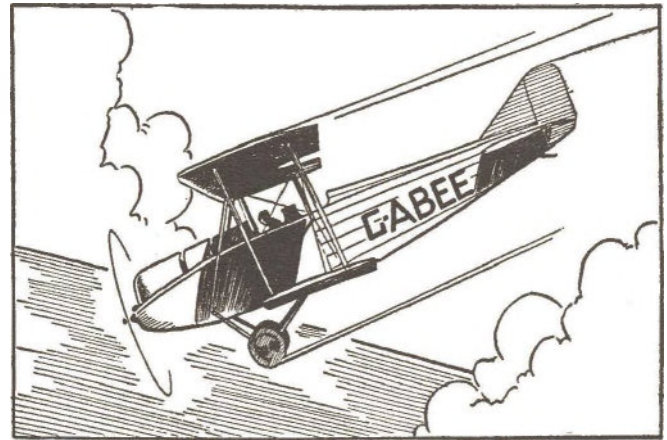

4—Meanwhile, the activities of Australian National Airways had lapsed, so Ulm returned home to revive them. But with the depression years badly affecting this worthy commercial venture, his reorganization plans went awry. Then Ulm again turned to record-flying. He went back to England, got an Avro Avian light plane—and flew it to Australia in seven days!

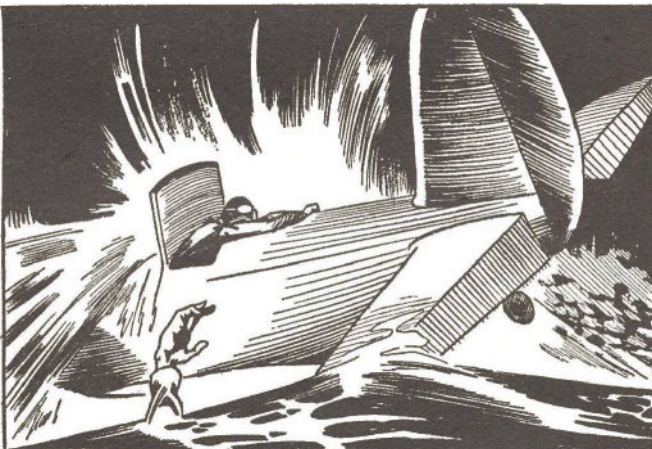

5—Next, this veteran sailed to the U. S., and in December 1934, he set forth from Oakland with two companions on what regretfully proved to be his last hop! Headed for Australia, he roared south-westward—and disappeared between the Mainland and Hawaii! Plane wreckage recently found in the sea near Honolulu may be the remains of Ulm's ship.



6—Not only was Ulm the type of pilot who could work successfully alone but he could also work co-operatively with others to achieve outstanding historical flights. He was to Kingsford-Smith in the sky what Britton was to Red Grange on the gridiron. And so Australia has written a great name on the World's Honor Roll of the Air—C.P.T. Ulm!

Sky-Power Facts

V
E
R
S
U
S

Sky-Power Fancies

* * *

THE UNITED STATES public has just come through another tidal wave of "first-hand" reports on the strength of European air powers. Too many of these much publicized articles have been written by self-appointed experts, though we're ready to grant that most of the writers involved have been sincere in their deductions. Some of these fellows who have "hit the headlines" have been to Europe since the crisis of last September and, under the rigid guidance of officials of the visited countries, they have managed to compile various charts and graphs which have been widely exploited by the newspapers.

Now here in America we enjoy what we like to call a free press. But we must remember that newspapers commonly have what they pointedly call their "editorial policy." And whoever writes articles for them must naturally conform. The policy may, or may not, lean toward the argument that the United States needs a greater Navy, a larger Army, or a more formidable Air Force. On this pro or con basis, then, articles are selected by newspaper editors.

Even so, it is surprising that the gentlemen who have gone experting for our public prints in Europe almost constantly disagree on facts, formulas, and findings. Is it any wonder, then, that the American man-in-the-street comes up out of the deluge still wondering what it is all about? He has been told on one hand that the British Empire has the most powerful and most efficient air service in the world—and he gathers on the other that the dear old Empire is "just about through" because what is left of the Royal Air Force is used for display flying at state funerals, or is busy buzzing around with kite balloon defenses.

The Republic of France, an air transport man tells us, has the most closely knit and most formidable air serv-

By David Martin

Author of "Sky Fighters of the North,"
"Deadlock In the Orient," etc.

With an Illustration by Arch Whitehouse

ice in the world—in the face of other statements that would have us believe that M. Cot has dragged the French Flying Force down to the point where it is comparable to that used by a third rate South American republic. Soviet Russia is held up to us as second to none in sky power—or else there is just one badly frost-bitten aircraft factory there, outside of which firing squads trigger volleys of bullets at the latest batch of mechanics who left a No. 6 nut off the blower of some Muscovite low-wing Special.

Italy, we are informed, is putting an awful fright into France and England because the Roman air service

is anything up to nine times the size of those boasted by the Limeys and Style-Setters put together—or else the Mussolini men haven't yet got over the shock of having their best planes shot down in Spain by 1927 versions of the Breguet.

Meanwhile, Germany is the big bad wolf of Europe's air forces, with anything up to 10,000 first-line sky fighting planes. Either that or she's an upstart nation militaristically with little more than a blamed good propaganda bureau.

The one thing that most of the returning experts *do* agree on is the sky power rank of the United States. We rate somewhere between Ecuador and Patagonia, they appear to have decided. And unless something is done quickly our country will be bombed off the map, gassed to a fare-thee-

well, and generally given the old Orson Welles.

The remarkable thing one notes about all these fancy experts who come back from abroad is the startling amount of statistics they can absorb with *one week* in Germany and a visit to *one* Heinie aeronautical factory.

But it is most pertinent to observe that none of them actually come out of Hitler-land with any real up-to-the-minute *detail* information—no more, in fact, than is to be found in the 1938 edition of *All the World's Aircraft*.

For instance, not one of them tells us what type guns are being mounted on these vaunted 10,000 German military planes, their caliber, or where they are mounted. Nor do we hear any—
(Continued on page 8)

JUST WHAT IS—
America's real air strength today?
The true measure of sky power?
Our best way to build it up?
The actual value of man power?
That bogey called "obsolescence"?

In this revealing feature, our article-writing ace, David Martin, has been given free rein to argue out these, and a slew of other, pressing questions in his own piercing, straight-from-the-shoulder way. And whether you see eye-to-eye with him or not, you'll surely agree that he's done a swell job in clearing the smoke screen from these much-muddled matters.



Left: Some of our National Guard flyers are getting fine training aboard North American jobs of this O-47 type. The true performance figures of this sturdy three-place observation craft are still "hush-hush," but it is believed to be very fast for combat tangles and suitably slow when artillery co-operation work is on the bill.

THESE FIVE TYPES OF FIGHTING PLANES PROVE—

that America is not so fast asleep as some of our newspaper-writing aero critics would have us believe. Basically, says Mr. Martin, we already have an excellent sky-power foundation—one upon which we can build an air bulwark second to none. And, he declares, the establishment of a single, unified sky force is the first step in going about it.

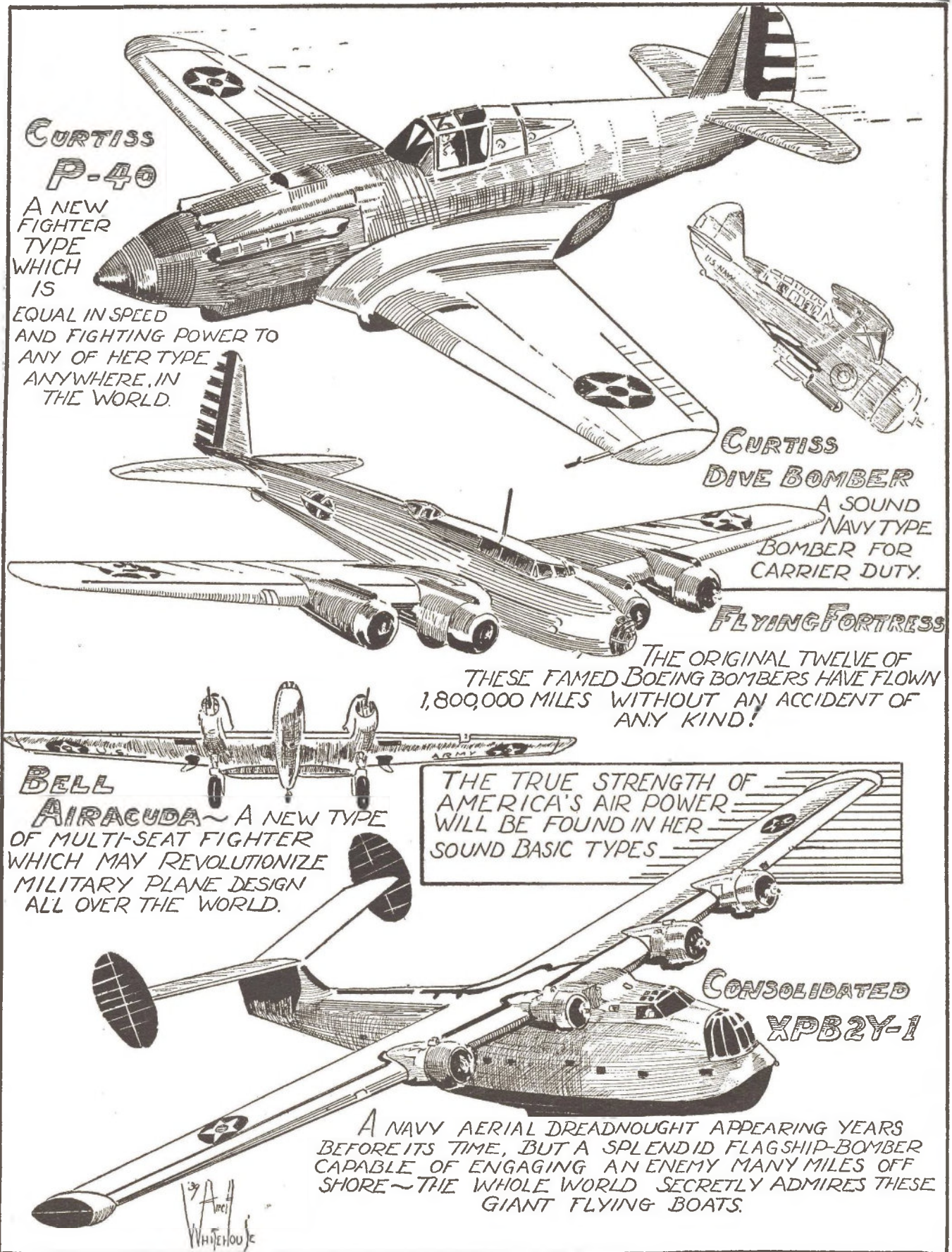

**CURTISS
P-40**

A NEW FIGHTER TYPE WHICH IS EQUAL IN SPEED AND FIGHTING POWER TO ANY OF HER TYPE ANYWHERE, IN THE WORLD.

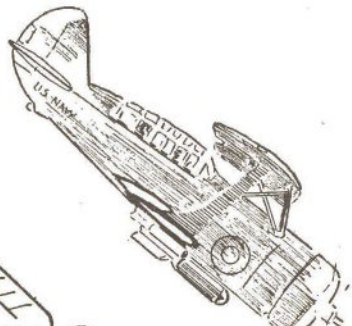

**CURTISS
DIVE BOMBER**

A SOUND NAVY TYPE BOMBER FOR CARRIER DUTY.

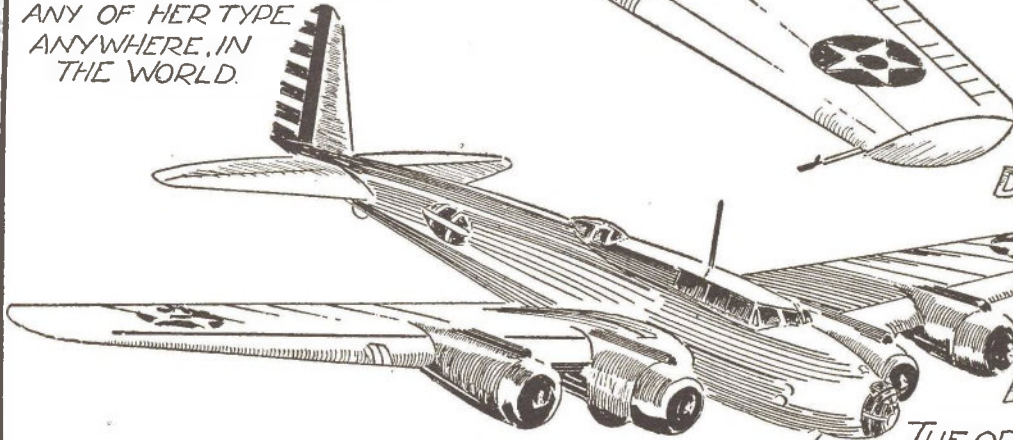

FLYING FORTRESS

THE ORIGINAL TWELVE OF THESE FAMED BOEING BOMBERS HAVE FLOWN 1,800,000 MILES WITHOUT AN ACCIDENT OF ANY KIND!



**BELL
AIRACUDA**—A NEW TYPE OF MULTI-SEAT FIGHTER WHICH MAY REVOLUTIONIZE MILITARY PLANE DESIGN ALL OVER THE WORLD.

THE TRUE STRENGTH OF AMERICA'S AIR POWER WILL BE FOUND IN HER SOUND BASIC TYPES.

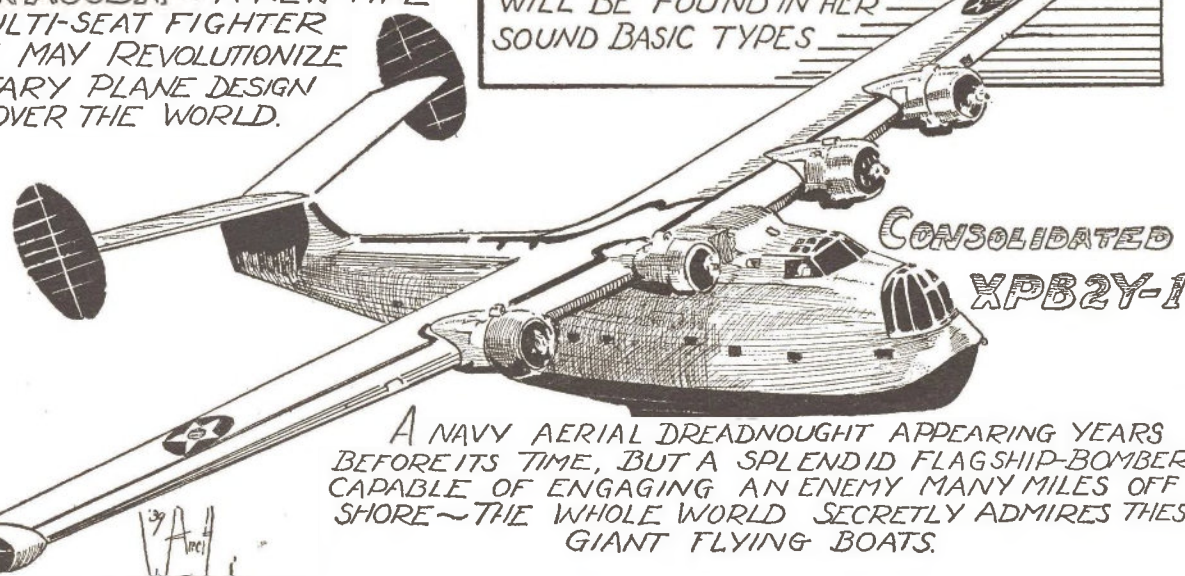

**CONSOLIDATED
XPB2Y-1**

A NAVY AERIAL DREADNOUGHT APPEARING YEARS BEFORE ITS TIME, BUT A SPLENDID FLAGSHIP-BOMBER CAPABLE OF ENGAGING AN ENEMY MANY MILES OFF SHORE—THE WHOLE WORLD SECRETLY ADMIRES THESE GIANT FLYING BOATS.

by A. H. Whitehouse

thing about the specific squadron disposition of all these fighting jobs.

As a result of all this ballyhoo concerning the strength of foreign air power, the United States has been whirled into a lather of rearmament, and President Roosevelt has virtually asked for 10,000 new fighting planes. And in the wake of this, many of the same experts who originally caused most of the excitement are now telling us not to get perturbed, to lay off trying to build 10,000 planes, that the country cannot produce 10,000 planes (although they just declared that Germany could and did), and that as soon as they are produced they would be obsolete anyhow. Some go even further by battling against the effort to turn out a big flock of new air pilots.

In other words, the lads who orated the loudest (after the Munich pact) that France and Britain should rearm, start conscription, and build or buy planes anywhere to stop the marching of Herr Hitler—now orate twice as loud when the same idea is suggested for this country.

BUT ALL THIS is aside from our intended subject. What we are trying to get at is a careful study of America's real air strength. What exactly do we have? And what precisely do we need? What is good equipment and what should be tossed out? Do we lack man-power, machine power, or both? Is our present "double" air service system right, or should we consider a unified sky force such as was long argued by Billy Mitchell?

Now before attempting to find the answers, it is only fair to state here that the writer has not been to Europe within the last twelve months. Nor has he flown any of the foreign fighters. And so, readers, don't hastily push forward to nominate him into the front rank of the aforesaid contrary aeronautical "talk-it-uppers."

But the writer has flown under war conditions, and he has studied military aviation for more than twenty years. And he asks you, therefore, to bear with him while he discusses air power as it relates to the American scheme, with which he is thoroughly familiar.

To begin with, the true necessity of air power, as we see it, is a complete aerial organization, unhampered by politics or association with either the Army or the Navy, except for mutual co-operation. Such a sky service should be designed to meet and overcome any direct attack made by any possible enemy. The leaders of this organization must take into consideration the geographical conditions involved—and it is not merely the strength of numbers that will count but also the perfect co-ordination of men and machines.

Air power, as far as America is concerned, must main-



Our Navy and Marine fighting squadrons are now getting copies of this new Grumman F3F-2. It is identical with the better-known F2F-1, except that it's powered with a 750-h.p. Wright Cyclone, whereas the earlier version mounted a 650-h.p. Twin Wasp Jr. Maximum speed of the F3F-2 is probably about 250 m.p.h. with its regulation load of Naval equipment.

tain certain standards of tactical efficiency, gunnery, co-operation, and squadron morale. Speed in itself is not enough, as has been shown in Spain, where the highly praised Messerschmitts and Fiats were often shot down easily by slower flying Russian Chats. Anyhow, when we are told about a new military type, we first inquire about its armament, where the guns are placed and the arcs of fire. As long as the plane has a dependable engine, we are not so interested in small m.p.h. variances. A ship's fight-ability is more complex than that.

We have learned from a young American engineer

that the Air Corps has issued requests for new single-seaters of pusher design that will do "at least 425-m.p.h." All this is very interesting, and we are waiting now to hear about the establishment of a special high-speed training school where exceptional pilots will be taught to fly them—if and when we get these fast buggies.

Until such a school is established, it will be impossible to find enough pilots with enough high-speed experience to fly 425-m.p.h. fighters and make up a complete squadron. The British pilots who are flying the new Hurricanes and Spitfires had to take the old Schneider Cup training course before they were allowed to fly the new speed demons. On top of that, they must wear a special body harness to keep their insides where they belong in high-speed turns.

At present it's our feeling that American pursuits or fighters are fairly comparable with any in the world. We have planes that do well over 300-miles an hour—if you must have your speed. Generally speaking, these ships of ours are well built, and have reasonably long ranges so that they can accompany our bombers out to sea to intercept enemy raiders in the air or on the surface. True, we have the same minor troubles that all countries experience in new equipment. The Seversky P-35 gave minor trouble with its bearings and the Curtiss P-36A fighter was grounded because of mechanical trouble in the retracting landing gear. But these points were merely mechanical and were easily remedied.

Here, we must speak about aero engines: For a long while, our country has been specializing in the development of air-cooled power plants for military jobs, and in doing so, we have attained the top in that particular motor sphere. However, with excellent liquid-cooled engines being produced abroad, together with Germany's success with the aero Diesel, we Americans are finally beginning to realize that we've got a bit lopsided in the motor field. After the last Curtiss Conqueror plant came off the line, we went dead on liquid-cooled engines—and saw foreign countries forge ahead with them.

But today we're seeing the light, with the new Allison liquid-cooled plants showing the way. We trust, too, that experimentation will soon begin on a top-notch American aero Diesel. Let's go, motor makers!

As for the design of Attack ships and in attack aviation tactics, the United States leads the world, we believe. But there should be more night flying to perfect this specific program. Our bombers are comparable to any on the planet, too.



Left: Twin-engined Attack jobs have recently attracted special attention from the Air Corps, and the much-improved Curtiss A-18, shown here, is an outstanding exhibit. The designers built first-class performance, long range of action, and plenty of low-altitude speed into this craft. She is fitted with the 1,000-h.p. Cyclone motor.

But they have a fault in the lack of good guns and suitable arcs of fire. Experts who should know—experts both here and abroad—agree that the Boeing *Flying Fortress* could be greatly improved by installing better gun turrets and more effective gun positions. The present “blisters” are efficient from a streamline point of view, but they are not particularly adaptable for real air fighting. Pertinent improvements have been started on the Douglas B-18, and they should be considered on the big Fortresses.

In Observation aviation, the United States has a wealth of fine material, both flying and co-operation, such as the best aerial cameras, and excellent communications devices. The Douglas O-46A's, now in use by nineteen National Guard units, are being flown regularly. Therefore, there will be trained personnel to handle these observation jobs should there be an emergency.

As to figures on Army air strength, we must take the word of Major General Arnold, Chief of the Air Corps, who states that at present there are approximately 1,500 first-line planes in our Army and that about 1,000 more are under construction or on order. It is also understood that about 2,000 multi-engined bombers are to be called for, although this figure is only approximate.

It is known, however, that there is a grim shortage of modern equipment in many of our squadrons—that some outfits have no planes at all. Meanwhile, the War Department is checking over several ideas for a new air cannon, and in the interim a temporary weapon is being put together at the Army Ordnance Factory. This trial gun is to be tested out on the new Bell fighters. We believe it is a 37-mm. gun, perhaps one similar to that devised by the American Armament Corporation.

We also understand that the Army Air Corps is experimenting with a new type of armor suitable for the protection of aircraft crews. And thus military plane design may be revolutionized. By a novel arrangement of various types of resistant sheet, this armor boasts the quality of deflecting even a high velocity missile. This is truly one of the first real forward steps in the sky-fighting line since the World War.

AS TO THE NAVY, no one disputes the statement that the United States has the most efficient system of aircraft carrier aviation, and American Navy flyers are among the most skilled in the world. We have six aircraft carriers afloat, all ready for action. At present, we understand, both the *Lexington* and the *Saratoga* are being somewhat remodelled. More elevators are being provided for moving aircraft up and down between the flight deck and the hangars. Also, that mechanical trouble noted in the new *Enterprise* and *Yorktown* has now been completely remedied.

Some of our cruisers have hangars carrying eight aircraft, as well as suitable catapults for launching. In addition, we have three aircraft tenders—the *Langley*, *Wright*, and *Patoka*.

The following numbers again are approximate, but we believe that there are about 1,500 first-line Navy

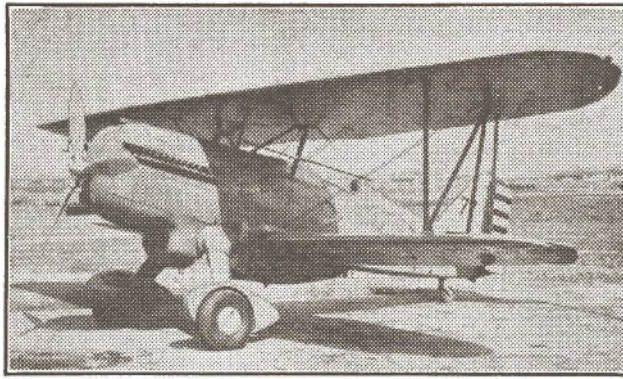

The Curtiss Conqueror engine you see mounted in this old P-8E Hawk represented one of America's attempts to find a good liquid-cooled engine that would stand up under strenuous service conditions. After it was given up, the halcyon days of the air-cooled power plants followed. But now the U.S. bids fair to stage a comeback in the liquid-cooled motor field with its promising new Allison engine series.

planes available and that about 700 more are on order or under construction. Here, we have to remind our readers that a great deal of the Naval Air Service money goes into the heavy patrol-bomber types. There are the Consolidated XPB2Y-1 and the Sikorsky XPBS-1. A new super-flying boat which will cost about three million dollars, is also rumored. Moreover, there are the Sikorsky S-40 Clipper type, the S-42, several Martin jobs, and other commercial ships to draw upon if an emergency should arise.

What are really needed are more bases, both fixed and mobile—for none of the Navy's three tenders is so hot. The *Patoka* has been designed for the accommodation and servicing of dirigibles, while the other two are admittedly obsolete models that should be replaced. It is quite possible, however, that the *Childs* and *Williamson*, obsolete destroyers, will be decommissioned and made over for aircraft tender duties. If, as has been hinted, the Naval Air Service is to be enlarged to 3,000 first-line planes, many more Naval air bases will have to be built to accommodate them. And we have before us the report of the Navy Board that 41 new bases are already under consideration at strategic points in the Atlantic and the Pacific. Twenty-five of these would be for the accommodation of Navy planes. Construction of fifteen of these bases will be begun in the future, according to a late report.

All this, then, should satisfy us that we have at least a sound *Basic* air force. Available figures give us a total of at least 3,000 first-line planes, which compares favorably with any of the nations likely to become a menace to the peace of the nation. Our flying service personnel is of the best. It enjoys as good training as any given to the men of other air forces.

Germany's force has been ballyhooed as comprising 10,000 fighting planes. But later and more conservative statements—from Naziland itself—have cut the figure nearer to the 3,000 mark.

The truth of the matter is that Germany will have all she can take care of with her European problems without attempting to bother the United States.

And what is more, it is now a well-known fact that Germany does not have a consistent fuel supply. Indeed, at the time of the September, 1938, crisis, she is said to have had only enough fuel for three weeks of active service flying!

Geographical conditions prohibit Germany from attacking the United States, for, while her pocket-battle-ship navy has been well played up in the press, it is known that it is not strong enough to attempt any

(Continued on page 55)

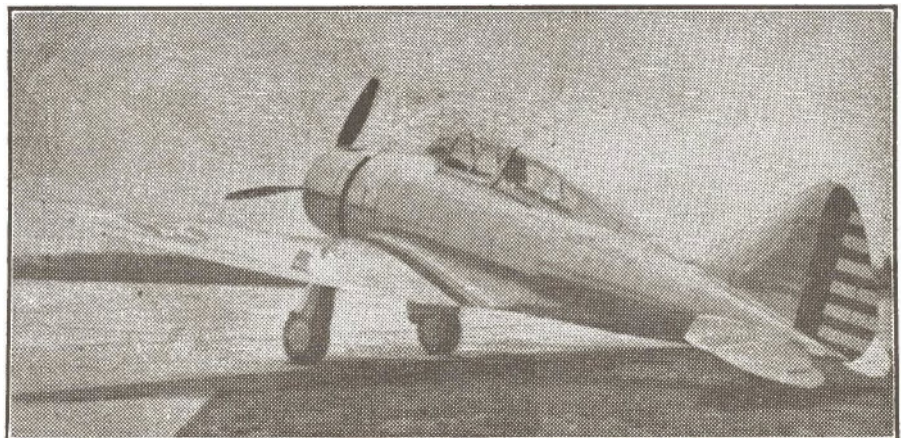

Right: Hailed by many experts as equal to any fighter type in the world, this Seversky P-35 has a top speed of 300 m.p.h., carries two Browning machine guns, and has provision for racks of light fragmentation bombs. The Army Air Corps has taken a batch of 35 of them.

Slaked Limeys

IF the British Air Ministry had not pitched a Camel drome near Bar-le-Duc in France during the Big Brawl, this particular screwball episode would never have happened. But let's get right into the story—

Major Frederick Fyer-Sayles put his flyers to work the same day they moved into the sector where Major Rufus Garrity's Ninth Pursuit Squadron of the U. S. Flying Corps was taking it on the button. And the first flight out they ran into a battle over Mont Sec between Captain Howell and his buddies and a quartet of nosy Alb crates.

Lieutenant Phineas Pinkham was certain that "A" Flight was doing all right without the help of the Limeys inasmuch as Bump Gillis and the Captain had each sent two Jerries well on their way to Valhalla before the winged Camel caravan showed their humps. Already the Boche camera bus that the Albs had been chaperoning was making a dubious landing on Allied real estate.

"Lookin' for cold meat, them beef-eaters," Phineas sniffed as a Camel whisked across the sky over his dome. "Beat it, you pip pips!" he yelled, not that any could hear him.

A Limey went down a sky chute after the very Von that Howell had bopped with a one-two punch from his Vickers. Meanwhile, the surviving Krauts were chased back over the lines into their own yard by Pinkham and Gillis, and when the two swung back toward Bar-le-Duc a captain of infantry squinted up at them from a trench on the border of No Man's Land and grinned like a villain in an East Lynne production.

By Joe Archibald

Author of "Kaiser Biliou," "Don Patrol," etc.

With Illustrations by the Author

Von Frankenstein's crate-crushing circus was giving it—and Garrity's valiant Ninth Pursuit Squadron was taking it. Right on the chin! Even so, the intrepid Yank cloud-scooters didn't cheer when Major Fyer-Sayles and his Camel riders came cheerio-ing into the Bar-le-Duc sector to teach the Munich Monster a lesson. And Phineas Pinkham? Yep, you guessed it! He was right on hand to strain the lesson before the Limeys had a chance to lessen the strain!

"That Spad right overhead," he said to a shavetail, "two guesses who's in it! You can recognize him by that nightshirt flyin' from the wing. That's Phineas Pinkham. And I'm not forgetting that crackpot. In Nancy he put *nux vomica* in my brandy. Well, it was a nice front seat we just had for this sky show. But if them buzzards think they'll get confirmation from *this* outfit, they'll—Well, what I mean is that those Camels were shootin' pretty straight today, Lieutenant!"

"They sure were, Cap'n! They sure were!"

MAJOR GARRITY'S SPADS were sweeping down to look things over. Phineas Pinkham spotted the wreck of the camera ship in a sheep pasture, and he also saw that a big Allied jalopy was stopping not far away from it. Two portly looking brass hats were piling out of the machine as the Camels were organizing overhead preparatory to going back to the Limey drome.

For a wonder, Phineas Pinkham, the miracle man from Boone-town, Iowa, was landing his Spad intact. He anteloped to the wreck of the Boche two-seater and got there just as a British red tab was poking the business end of a service pistol into the prop boss of a bleary-eyed Heinie pilot.

"What's goin' on here?" Phineas wanted to know. "I demand that you stop botherin' the prisoners of the Ninth Pursuit Squadron, as did you have to climb upstairs and knock down a Kraut who was already coming down? Take your fish-hooks off, you tea guzzlers."

"Blarst yer eyes, you bloomin' blighter," the red tab huffed. "I 'ave prevented this 'un from hescapin' at the risk of my own life. I disarmed 'im after a bit of a struggle and 'e's my prisoner, what?"

"Wait 'til I say somethin' before you act like you was deaf," Phineas bridled. "He is the prisoner of the Ninth Pursuit Squadron. You say you got him 'after a bit of a fight,' huh? Why, that Kraut could not pluck up a daisy with both hands. Awright, take your water pistol and put it in your pocket, as I bet it's so rusty it wouldn't—"

"Gad, Colonel, did you ever see the like of 'is cheek? You're jolly well

Boyles-Ryce began to complain of a terrible disturbance in his mid-section. Then three more Limey Camel drivers got as green as turtle soup and called for double-quick first aid.



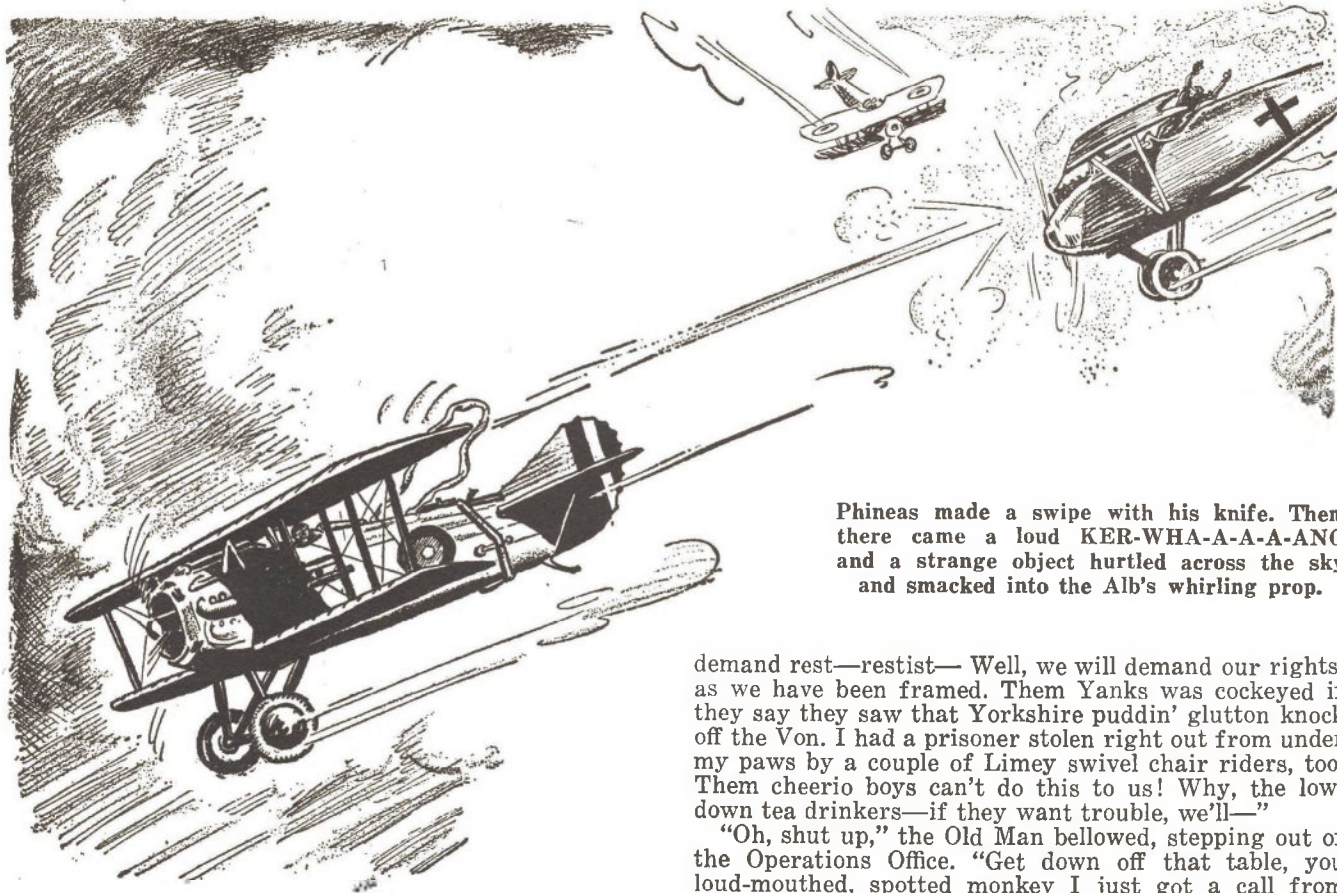

Phineas made a swipe with his knife. Then there came a loud KER-WHA-A-A-A-ANG and a strange object hurtled across the sky and smacked into the Alb's whirling prop.

talkin' to a superior hoffer, you—you blinkin'—! Take the prisoner to the motor car, Colonel. I'll—what's your name, Leftenant?"

"John Doe."

"Hmph! Want to pull my leg, what?"

"I wouldn't mind," Phineas countered. "Just step over here an' I'll tear it loose right from your shoulder. Haw-w-w-w! Awright, I won't kid you. Here's my right name—Paul Revere."

"That's better, Leftenant," the red tab snorted. "Now get along with you, Revere. I will report your insolence to your squadron commander. Colonel, these papers from the Boche's pocket will please Brigade no end. Map of Jerry ammo dump near Sproud! Topping, eh, what? A little bit of hall right!"

"The bums!" Phineas yipped. Then he shot a look at the Kraut that the red tabs had confiscated as their own property. The Teuton had now gathered his marbles again, and by the look on his square pan, he seemed ready to try to make a break for dear old Potsdam at the first opportunity. Reluctantly, the Yank went back to his Spad and got it off the ground with a low zoom that nearly scalped the red tabs who still stood beside the wreck of the Heinie camera ship. And when he got upstairs he saw that the Britishers were having quite a time of it chasing the Boche around the field.

The Ninth Pursuit Squadron's troubles with the Limeys had not even started, however. An hour later a Camel pilot claimed the Heinie that Howell had knocked down, and Major Rufus Garrity regretfully informed his buzzards that a Yankee infantry outfit near the Meuse had confirmed it. Captain Boyles-Ryce, Limey flight leader, had been credited with the descendu and no mistake.

So tempers went berserk in the Frog farmhouse outside of Bar-le-Duc. Phineas Pinkham got up on a table and delivered a tirade that would have made an anarchist's beef sound like a recitation of Little Bo Peep.

"We will not stand for it from them pip pip bums!" he yowled. "We will go over to the Limey squadron and

demand rest—restist— Well, we will demand our rights, as we have been framed. Them Yanks was cockeyed if they say they saw that Yorkshire puddin' glutton knock off the Von. I had a prisoner stolen right out from under my paws by a couple of Limey swivel chair riders, too. Them cheerio boys can't do this to us! Why, the low-down tea drinkers—if they want trouble, we'll—"

"Oh, shut up," the Old Man bellowed, stepping out of the Operations Office. "Get down off that table, you loud-mouthed, spotted monkey I just got a call from the British drome. They demand an apology from Paul Revere! Now what in—"

"Haw-w-w-w-w!" Phineas guffawed enjoyably. "It will be a long trip before they find where his bones are. Pull my leg, eh, what? Pip! Pip! They were a howl. I wonder did they catch the Von, as when I saw them last, they—er—I mean, I heard about it. A dough told me, an'—"

"You're a plain and fancy liar," Major Garrity erupted. "Only *you* would give that red tab a name like that!"

"Well, he wouldn't take John Doe—er—awright, I insulted the Limey fatheads. They were stealin' our prisoner—and how long will we stand for this, fellers? Are we mice or are we men, huh? Blarst the blinkin'—er—we will show them fish-and-chip chappies, eh? We licked 'em in '76 and 1817—and we can lick 'em again. My great-great-grandfather, Benjamin—"

"That's enough out of you, Pinkham!" Garrity roared. "We can't expect to win this war without co-operation from the British squadron. We're shorthanded here, and the French have been catchin' plenty of hell for the last week. We need those Camels in this sector, and if I catch you promoting more bad blood between those British flyers and this outfit, I'll bust you wide open from your tonsils to your heels."

"That's the old fight!" Phineas snorted disdainfully. "A burgler robs your house an' you find out his address and take him the silver he overlooked, haw-w-w! We get robbed by the Limeys and then turn our kissers for another punch in the chops. Of all the *guerres* I was ever in—well, I will not be polite to them pip pips. I'll get hunk! They are still sore at us for dumpin' their tea overboard an'—"

HR-R-R-RO-O-O-O-O-OMM!

WILD YELLS came from the outdoors. A machine gun chattered and Sergeant Hugh Casey dived through the door and skidded to where Phineas Pinkham stood. Bullets came in after Casey and stabbed holes in the floor of the Frog farmhouse. A bottle of catsup broke up near the C. O. and its contents made a mess

● PHINEAS PINKHAM IN A "PIP-PIP" PICKLE ●

out of his tunic. Flyers pancaked, wriggled to whatever protecting screen the room offered.

When the shooting was over, Bump Gillis crawled out of the fireplace with Captain Howell and Phineas came out of Glad Tidings Goomer's domain on all fours. He had a dishpan over his head and was hollering that the mess monkey was wedged under the stove and could not get loose.

"It—it was that Boche Baron!" Casey choked out. "Rittmeister Fritz von Frankenstein. He ain't human. That's the th-third time he has come over an' shel-lacked us. Why don't you aviators do somethin', huh?"

"Sergeant," Lieutenant Pinkham growled with mock dignity, "you forget your rank, as we flyers demand some respect. Von Frankenstein, huh? That bum! I'll get him yet. I'll—"

"You better hurry," Garrity sneered. "He's got 79 victories so far. In another month they'll be calling the late Red Knight a piker. There's 200 British pounds for the flyer who brings him down. They might as well make it a million. Great sports, the Limeys! Ha! Ha! They'll be offering the first man to swim from Australia to Alaska a million pounds before we know it. All right, break this up! Casey, get out of here. We don't want you gold-bricking around the drome. There's a Spad or two, I believe, that are not exactly in the pink."

Phineas Pinkham had been thinking. The Old Man's last remark to Casey had given him an idea. Gold and pink. Colors! He went over to his hut where his mental assembly could function in high gear without interruption. After awhile his ingenuity went into operation and he decided to take a trip to Bar-le-Duc as early as possible. The Limeys, he told himself, had better have plenty of proof the next time they stole a descendu when there were Spads around.

Phineas was giving his mental attention to the von, too. For ten days the Boonetown Bam had been aware of the fact that the Munich Monster had been hogging the spotlight in Mars' playhouse. Moreover, he had made disparaging remarks about Lieutenant Pinkham. Just three days ago he had dropped a package down onto the drome of the Ninth, and in it was an article of wearing apparel. A present for Herr Lieutenant Pinkham—a pair of feminine skivvies trimmed with pretty lace.

As a result, Phineas had taken more ribbing from his flying mates than could be found in a million umbrellas. That had been the unkindest cut of all. So far as Lieutenant Pinkham was concerned, the war correspondents could describe the big *guerre* program thus: "Phineas Pinkham vs. Von Frankenstein. To a finish. Winner take all."

The events of the early patrol were also still irking the spleen of the resourceful Yank. He knew all about the Camel layout. D.H.4's had once used that Frog real estate plot before being moved to what Chaumont considered a more strategic location. Phineas took a box of cigars from a shelf and started crumpling the stogies to bits.

"Limey wisenheimers," he growled. "The Yanks fixed their tea wagon before. I'll give 'em more than the pip-pips, all right. Now to fix that flying coat sleeve—"

"A" FLIGHT went up after the early patrol had returned a little the worse for wear. Von Frankenstein had been out looking to fill some more graves, and he had not missed by much. Howell and his surly brood saw little in the way of Potsdam sky stock. They

sent a Rumpler back to the Rhineland for repairs. But that was all. Finally the flight leader swung back home and signalled to his mates to follow. But Phineas Pinkham took a detour on his own and had a forced landing on the British drome run by Major Fyer-Sayles, K.B.

"Cheerios an' all that bloody rot!" the Boonetown Spad jockey called out to a Limey topkick. "Must have petrol no end, eh, what? Haw-w-w-w! Fawncy anythin' on a Limey drome bein' out of gas! Hop to it, Alfie!"

"The nyme is Cuthbert to yer, Leftenant!"

"Haw-w-w-w! Well, I got to get fueled up, anyhow. And where is there a drink of water on the premises? Oh—er—is that a well over there, Cuthbert, ol' thing?"

It was a well.

Then three Limey officers trotted over to the oasis just as Phineas Pinkham was lifting himself a pail of cool water. He took a gulp, set the pail down on the edge of the well, then exclaimed: "Strike me pink an' even pink-er! If it ain't the jolly Rogers! I bet you still think you shot that Kraut down yesterday, you bums. You would steal the fillin's out of teeth, you—"

A Limey with a well-waxed mustache introduced himself as Captain Boyles-Ryce. "Why, Leftenant, where are your American manners, eh, what? We jolly well no sooner arrive in the sector than you Yankees try to steal a Boche from us. Tsk! Tsk! Atrocious manners, ol' turnip! What? Now, Leftenant, you blinkin' well know—"

"Listen, you cheerio bums," Phineas yipped as he kept one arm over the

rim of the old oaken bucket, I still say you robbed us! You and your red tabs. That puff adder you call a colonel stole our prisoner, too. Oh, I won't forget you bums with the pip. A Pinkham never forgets any more than an elephant. If I see one of you gettin' shellacked by some Vons and I am going by, I will make out I didn't see a thing. I jolly well will, old radishes! Pip pip, what? Well, I guess I'll get going before you steal my watch."

The Limey non-com came up and said: "Leftenant, yer Spad weren't empty, naw. Yer 'ad 'alf a tankful, yuss."

"No kiddin'?" Phineas grinned. "I'll have to get me a new measurin' stick, Cuthbertie, ol' thingie. Well, over-the-river, toodle-oo, and some more cheerios."

The Limeys watched Phineas take off and disappear into the hazy ozone. Boyles-Ryce shook his head. "Wonder what the beggar is up to? Got to keep an eye on that freckled chap, eh, what? We jolly well got the wind up on the Yanks, no end. Their kites are blowin' 'igh!"



"Well, Cuthbertie ol' thingie," chirped Phineas, "I'll now bid you over-the-river, pip-pip, toodle-oo, and cheerio."

THAT NIGHT the Limeys wondered what was the matter with their tea. They complained to Major Fyer-Sayles. Captain Boyles-Ryce said: "Terrible taste, Sir. Perfectly filthy. Drank two cups of it, Sir, to see if we jolly well imagined it. 'Ave a spot of it, Sir?"

"Quite, Cap'n. Possibly an inferior grade, eh? I'll look into this. British Expeditionary Force no stronger than their tea, y'know. Yes?"

Major Fyer-Sayles sipped at a cup of the stuff. He wrinkled his nose, then his brow. He took a big gulp, then drained the brew and smacked his lips. "Deucedly odd," he mumbled. "Gad, I know tea. This is most 'orrible, Captain. Call the mess sergeant at once. Possibly a tainted pot he—"

There was nothing amiss so far as Timmins, the mess
(Continued on page 73)

Snapshots of the War



Above: This Albatros D-2, flown by Oberleutnant Friedrich Karl, Prince of Prussia and an officer in the German Air Service, was shot down in 1918 by a Royal Air Force pilot flying a Sopwith Pup. The Prince later died of his wounds, although he did manage to make a fairly good landing, as will be noted by the excellent condition of the plane. That number "8" on the side of the fuselage somehow makes her look like a racing job.

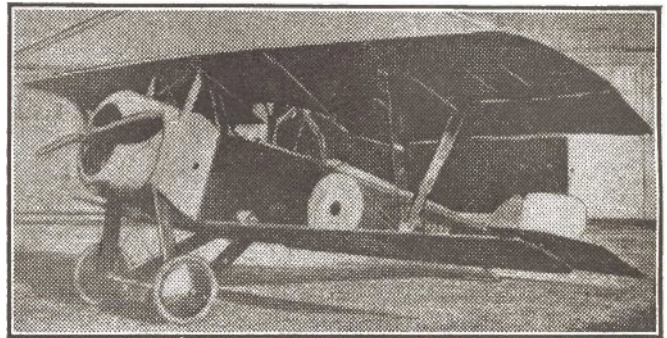

Here's an unusual type ship for all you scrapbook fans. It's the French two-place Nieuport 14W-2C. A close examination of the photo will disclose the unusual rear gun mounting designed to afford machine gun fire forward and over the prop arc. This system was used before a successful Allied synchronization gear allowed gunning through the aircrew. And say, how'd you like to land a ship with such a stiff undercarriage?

Below: A German plane with Allied markings? Yep, this ship—one of the famous Argo seaplanes—was shot down by a Canadian squadron working with the British Royal Naval Air Service. Then it was painted with English insignia and flown to an engineering base, where it was carefully studied. Note the swept-back wings, the stepped hull and the cockpit which appears to be completely enclosed! Seems like our "modern" improvements are not as new as we thought.

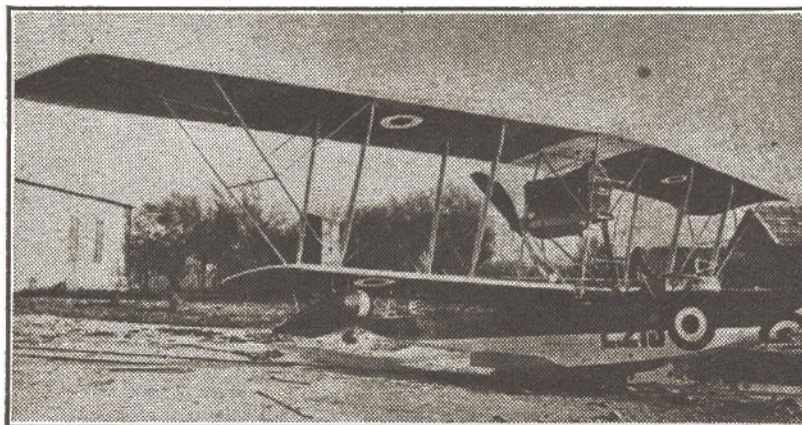
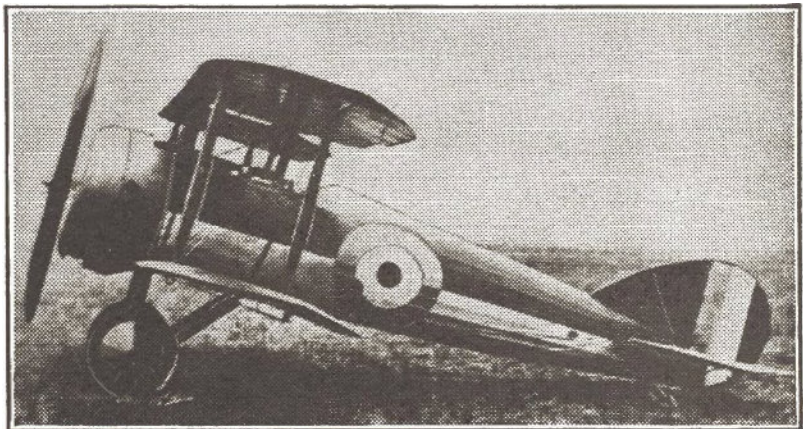

Above is a little known plane of the World War. Listed as the Vickers Bullet, this ship appears to be a combination of the Camel and the Spad. A 210 h.p. Clerget rotary was probably used as the power plant. Although we did a lot of digging in the files, we couldn't find any record of this type ship ever having been put into production—but she does look like a sweet flying job.

These Photos are From the Collection of
W. R. R. Puglisi

Below we have one of the few available pictures of the rare Fokker E-IV. Oswald Boelke, one of the most famous German flyers of the Big Scrap, used this plane as his personal ship. Especially interesting is the fact that this type was the first of the renowned Fokker brood of sky fighters to be fitted with two Spandau guns firing through Tony's early gun gear system.



Left: Seated in his favorite Fokker triplane ready for action, we here see Heinrich Goettermann, officially credited by the Kaiser's war office with 39 victories. And there's plenty of determination reflected in this ace's face, too. The loading mechanism of the Spandau guns, the small wind screen, and the distinctive German-type goggles may be observed here. Our print also indicates that Goettermann, like the present-day Fuehrer, was partial to a close-cropped mustache.

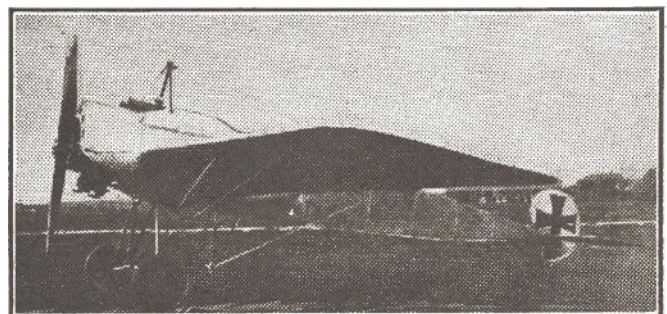

"While we were still wondering about the reason for the extra altitude, Leader Flugler made a wide, diving turn that almost scattered the whole flight!"

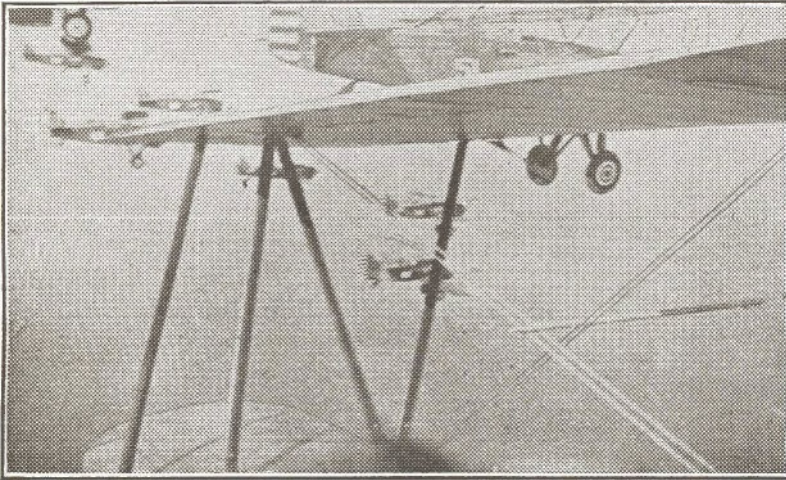

By Frank Lambert *Army Flyer*

IN THE SKY, all flyers are brothers. Especially is this true of military pilots when they are flying in close formation. And when they are roaring along just a few feet above the ground, the relationship is stronger than blood.

Every formation maneuver, you see, must be performed like a perfect play in football. Let any pilot miss a signal or slip out of position, even for a second—and several lives are endangered. For the slightest contact between two planes may result in instant destruction for both of them. And often for others nearby, too.

You've got to have altitude in order to bail-out or recover control—and altitude is something that Attack pilots must learn to get along without.

Formation work at a spare 75 feet—the regulation Attack altitude—is most unpleasant unless you have complete faith in the men around you, particularly the ones just behind. When you lack this confidence that the man behind you is going to manage somehow to keep his prop away from your tail and out of your hair, every turn near the treetops becomes a nightmare. But with plenty of trust in the flyer on your tail, you are free to concentrate on proving to the airman ahead that *he's* justified in having faith in *you*.

My first real scare in flying came from lack of confidence in the man behind—and it was the man ahead who almost paid the price!

WE WERE STUDENTS, just learning to fly the flat formation peculiar to Attack aviation. And perhaps I had better explain here just what is meant by this. As anyone knows who has watched military flying, all formation work is based on the three-plane "element," each element consisting of a "leader" plus two wing-men flying slightly to the rear, one on each side.

When the leader banks his plane for a turn and the others bank with him, the wing-man on the outside of the turn pulls up, while the one on the inside drops down a little so that the wings of the three planes are kept in line and the whole element banks like one big plane.

That was the *fundamental* system we had been taught. But when we started training for advanced Attack work we had to learn a more difficult method.

"Take it from me," says Frank Lambert, "this business of learning the low-altitude method of surprising enemy ground troops calls for a type of 'compressed flight' that packs the close-shaves of a life-time into an everyday routine!" And Frank knows because they had him doing it. But hardly had he got used to this regular flying fare of cutting it fine, when hare-brained Element Leader Flugler came along and cut it finer than that—

"Attack

Attack flying, they told us, really means *ground attack* flying, and pilots who train for this branch of military aviation must learn to fly as near to the ground as possible, even when flying in formation. To sneak-up on ground troops and nail them before they have time to scatter is the object. In short, they explained to us that Attack pilots must learn to fly a "compressed" formation at all times. That's the easiest way to fool the enemy.

But we quickly found out that it is *not* the easiest way to keep out of trouble.

We began as wing-men, flying beside our instructors. And initially we kept dropping down on the inside of turns—for it was the natural thing to do. It prevented us, you see, from "running over" the leader when he turned toward us, and it kept our planes in the same relative positions as when in level flight. That way, we could still see the leader's plane by looking out between our wings.

But when they began instructing us always to keep the leader's head "on the horizon" our peaceful days were over. It sounds simple, but it isn't. It means that when the leader turns in your direction you cannot drop below and partially under him to turn on almost the same radius. You must make a steeper, shorter turn on the *same* level and cut your throttle quickly to avoid over-running him.

Many times I failed to drop back early enough, causing my lower wing to "cover" the leader as we rolled into a bank. Then, when he turned in the opposite direction, I often was a bit late in finding exactly the right position, whereupon his plane would be entirely hidden by my top wing.

Of course, when I could not see his plane I had to pull away in a hurry, locate him again, then try to catch up once more to meekly take my place in the formation. At best, only the wheels of the leader's plane were visible while he was turning away steeply, and only the nose of his plane could be seen by the opposite wing-man on the inside of the turn.

In the new monoplanes, visibility is somewhat improved. But Attack formations are still ticklish, no matter how many times a flyer may have flown them. Those turns especially!

They were certainly ticklish for me. The thing was that I wanted to be very considerate of my instructor. In fact, just to make sure I wouldn't run into him when he turned toward me, I continued to drop below him in the usual formation style.

But he showed no gratitude for my good intentions. For several days he kept waving me up, and he always politely called my attention to my error after we landed. Still, I didn't seem able to conquer my cautious tendency to slip down just a little when he turned toward me.

ONE MORNING he ceased waving me up to the proper level—and I looked for trouble. It came! Just before the next flight, he called me aside and spoke very briefly and to the point: "I am afraid you haven't enough nerve to become an Attack pilot. Anyhow, now we are going to find out."

We took-off but did not climb. The blurred pattern of ploughed fields, pastures, and mesquite thickets sweeping past a few feet beneath my instructor's wheels! Boy! I have to admit I became

Formations are Ticklish!"

slightly dizzy. One wrong move—and it'd be curtains!

The instructor kept glancing back at me. Then he would stare suggestively at the various objects that were passing not far below my own wheels. Finally appearing to be satisfied, he nodded his head and began a turn toward the other wing-man. I opened the throttle and followed him around as closely as I dared, afraid that if I lost my position a hill or a tree might get in the way before I could get my bearings.

After we straightened out, he took one long, sober look at me as though trying to make up his mind about something. He seemed to be taking a kind of *last* look, and I could feel perspiration trickling down from my arm-pits. Then he nodded his head in my direction and turned his plane toward *me!*

I jerked the throttle, held the stick tightly as we rolled into the bank, held my breath, and tried to hold my position. I knew that as long as I could keep my eyes in line with the leader's head and the horizon I was no nearer the ground than he was—and he was *quite* near enough, so I kept that line-up tenaciously. I knew that if I took my eyes off the leader to watch the ground I would probably run into him—and end up on the ground anyway. So I was determined to stay close—and to stay up.

When we straightened out—safely, thank heavens!—his expression did not change. He continued to make turns. He flew even nearer the ground than before. I was tense and rough with the controls, but at least I did not slide downward on the inside of any turns. Thus no mesquite trees were damaged. Meanwhile, I was perspiring so freely that my goggles fogged up and I

had to push them back so I could see clearly again.

At this point, my instructor began to smile faintly, and soon we returned to the field. His face still bore the trace of a grin after we landed.

"I notice," he said slowly, "that you have quit dropping down on the inside of turns."

I said "Yes Sir" very weakly. I was exhausted—but I was still an Attack pilot!

SUCH A TEST as that just related often served as a final examination on that first principle of Attack flying—which was "Stay Flat." A pilot who cannot overcome his tendency to rise or drop with his leader's wings has no business in an Attack outfit. For the larger formations are also kept as flat as possible. Now then, a normal "Flight" consists of three elements of three planes each, with the second and third elements slightly to the rear of the first and lined-up at a 45 degree angle on one side or the other. Anyway, when the leading element makes a right-angle turn, the second and third elements must cross over to the inside of the turn. If they didn't, they'd be left behind. This maneuver we found to be a fairly easy one, even though we had to cross over mighty close above the tails of the element ahead.

But when the leader turns *toward* the second and third elements, the pilots in the formation really begin to earn their flying pay! For when this happens, the leader is turning his element directly into the path of the other six planes. They, of course, turn with him. But while a wing-man may slow down just enough to fly the turn on the inside and not get ahead of his leader, a whole

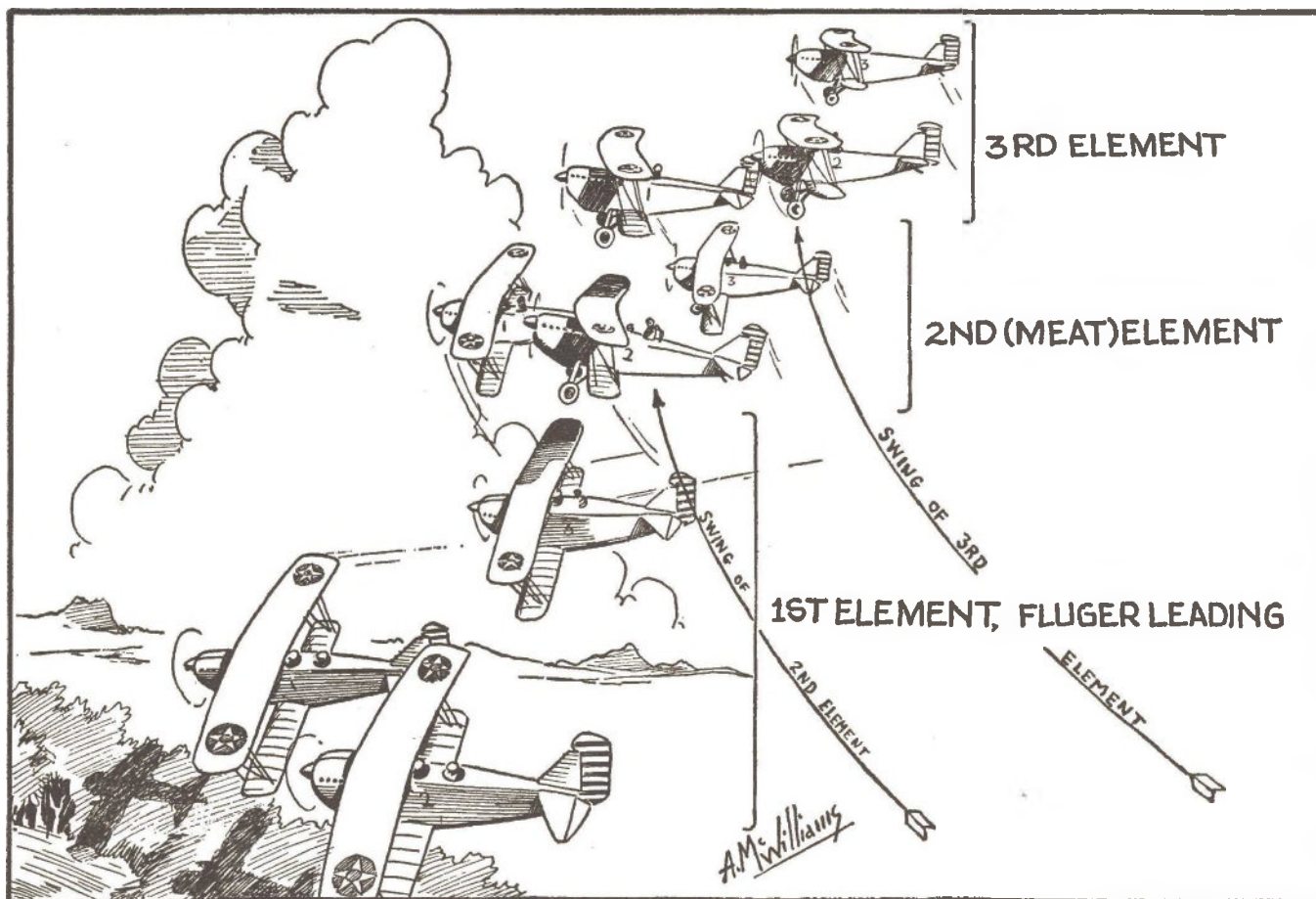

An abrupt wrong-way bank while "grazing" a hill top! It was this erratic maneuver, sprung by the German student, Fluger, leader of the First Element, that got the writer and his fellow attack flyers into a jam. This graphic sketch by our artist, Alden McWilliams, illustrates the episode. The First Element having just turned, we find the Second and Third Elements still in the act of swinging over. And we see the author—piloting Ship "2" of the "Meat" Element—badly caught, during the cross-over, between the upper wing of the First Element's Ship "3" and the wheels of the Third Element's Ship "1."

element simply can't do it.

That's because the difference in distance is too great. Since airplanes cannot stop and mark time while the leading element swings around on the outside, the second element must slow down somewhat and cross over during the turn, finishing on the opposite side and thus equalizing the distance. At the same time, the third element must be crossing over the second—with the result that the second element is literally sandwiched between planes crossing above and beneath it at the same time. That was why we called the second unit "the meat element." And that was why I was not very happy while flying as a wing-man in the second element of those student formations.

OUR WORST MIX-UP happened as we were nearing the completion of our training. The instructors had almost finished with us, hence they no longer formed a part of the formation but instead flew at a distance, from where they watched us practice our formations for the final review.

Now then, the job of leading the nine-plane flight was intrusted to a German Army officer named Fluger—a veteran war-pilot who was attending the school as a student and was about to graduate along with the rest of us. Granted, he was a good pilot—no doubt he's one of Hitler's best today. But he lacked smoothness and his abrupt method of maneuvering made him a difficult leader to follow.

Furthermore, he had little regard for our inexperienced nerves: Once when I came in from a flight on my wing, mechanics discovered oil spattered on my plane and were mystified when they found that it was not *my* engine that was throwing the oil. Then I remembered that Fluger had swept us across a formation of bombers and that I had looked right into the cockpit of one of them as I skimmed over. Sure enough, we learned that the bomber had a bad engine that was throwing oil. It was almost unbelievable, but the oil that spotted my Attack plane had undoubtedly come from the engine of a bomber flying in *another* formation!

But I would have preferred rolling my wheels across bomber wings to being a wing-man in the "meat element" of one of that German's "flying circus" formations! The Chief Instructor had already warned him about some of



"In another instant, I was back in position and my heart was trying to make up for lost beats. Then, quickly I began counting the other planes."

his worst antics—after he had stampeded a herd of cattle into breaking down a corral fence on one occasion, and almost knocked a brakeman from a freight train on another.

Fluger, however, took all these reprimands with good humor. His last bawling out had come after he had scattered our formation by putting us into a flying column and then pointing his nose at the sky, all of which left us floundering in a chain of propwash.

"Couldn't you see that the other planes were stalling and falling out of formation from trying to follow your steep climb?" demanded the Chief Instructor gruffly.

"Yes," replied the German sadly. "They were terrible!"

On the morning of my big scare, Mr. F. seemed calm enough at the take-off. It was a sunny day and the rising air currents caused even our steady old Curtiss A-3 Falcons—we didn't yet have the Northrop A-17A's—to pitch about considerably.

But when I looked past the leader of my own element, I could see that our Jerry flight leader was already clowning. As his plane pitched and bucked in the rough air, he patted the cowling and pretended to soothe it as though it were a horse. To our surprise, he then led us all the way up to fifteen hundred feet.

While we were still wondering about the reason for this extra altitude, he made a wide, diving turn that almost scattered the whole flight. No, flat formations are not suited for climbing or diving turns. Nevertheless, he continued his dive, and by the time we regained our proper positions the flight was roaring low over the flying field, *downwind*.

Below us, a squadron of pursuit planes had arranged itself in formation on the field. And it was just about to take-off when the leader saw us coming. We could see the startled faces of the pursuit pilots turn up at us as we passed directly over their heads.

All our planes were now flying just a few feet above the ground to simulate the attack, but after we crossed the field the second and third elements had sense enough to rise to a higher level in preparation for a turn. Friend Fluger then turned away from the echelon—as he was expected to do—so there was no difficulty.

But that surprise "attack" on our own airdrome was

(Continued on page 72)

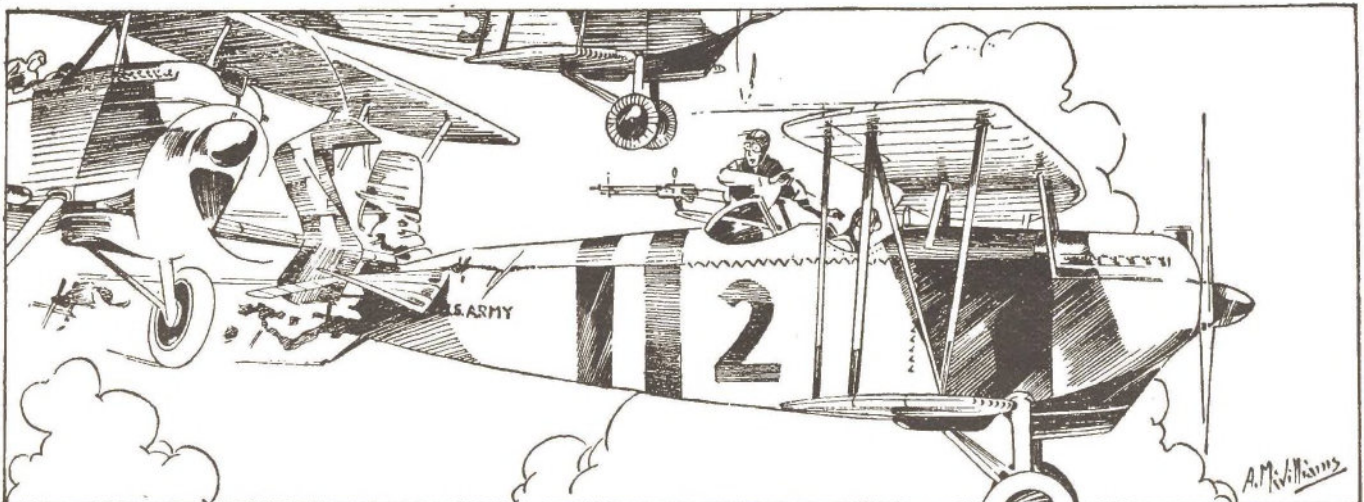

Frank Lambert's striking revelations of Falcon formation flying bring to mind the heroism for which Lieut. Robert D. Moor was posthumously honored with both the Cheney Award and the Distinguished Flying Cross in 1931. When a wing-man, thrown momentarily out of control by an "air bump," smashed the tail of his plane, Moor valiantly stayed with his plunging, damaged ship until he finally got his badly-stunned observer to bail out safely. But by that time, it was too late for Moor to save himself. He was killed in the terrific crash that followed.

If the "New Caesar" Raids "Carthage"

THE DRAMATIC STORY BEHIND OUR COVER PAINTING

* * *

WE IN THE UNITED STATES, reasonably secure in our geographical position, are prone to consider Europe as a veritable seething pot of war. We can point out how for centuries bloody battles have been fought on the nationally-conglomerate continent across the sea. We have read of great marches across the Alps, retreats from Mons and Moscow, the battles of Austerlitz and Waterloo.

But for determined and indeed almost continuous strife, what are all these as compared to the raging combats that have been staged at Carthage? That great city of antiquity, founded in 814 B.C. by the Phoenicians, was destroyed for the first time by the Romans in 146 B.C. And thereupon was born a heritage of war and destruction that stimulates the imaginations of men to this day.

Most striking of all is the fact that this historic battleground may now once more become the scene of strife—for France's modern city of Tunis in north Africa lies at the very site of ancient Carthage!

Consider the fact that this teeming center, which more than 2,000 years ago was attempting to resist the raids of Roman Legions, is now threatened by the winged warriors of a modern Caesar. Two thousand years have brought a new civilization. Yet Carthage (its new name of Tunis does not alter the point) is still menaced by the Roman Legions!

The insistent clamor for the possession of this commanding African post is truly an old story. France and Italy have had these arguments before—and they will continue to have them as long as the ancient site of Carthage is the strategic stronghold it is. A glance at your map will show how this projecting section of land, if properly fortified, can be a major factor in swinging the destinies of the Mediterranean if Mussolini should decide to carry forward his present plans for a new Afro-European empire.

Yes, Italy fully realizes the value of the "New Carthage"—and France, its present holder, knows it. Meanwhile, Great Britain will probably be satisfied as long as this fought-over colony remains in friendly hands.

The Berber natives of Tunisia have seen their land swept in turn by (take a deep breath here) the Phoenicians, Romans, Vandals, Arabs, Spaniards, Turks, and the French. These followers of Mohammed must view the ruins of ancient Carthage—once termed the "Queen of the World"—with mingled feelings. For it appears that a lasting peace is not to be.

France-held Tunisia is considered a menace by the new-day Romans. Indeed, it can actually be seen by many Italians, since it lies less than 100 miles across a thin strip of sea from Marsala, in Sicily. Thus, the nationalistic men of Mussolini would be happy to back

a military effort to regain this commanding outpost.

In the interim, the true Tunisian patiently hopes for the day when he can throw off *all* foreign yokes. The young men of the land would welcome the time when Tunisia can take its individual place in the great State of Islam and help re-unite Africa with the East.

The Italians know all this, too, and they'd very much like to play the native element against France, hoping to gain Italian loyalty along the route. Mussolini understands the value of military display, and he has made the most of his efforts in Ethiopia. Now his propaganda bureau is taking great pains to "sell" the Tunisians on the advantages of Italian rule and Italian protection. The Tunisians, on the other hand, are probably willing to play this diplomatic game, as the French oppose the Italians, in hopes that out of any resulting war they may be able to rise to demand their own national freedom.

As a background for a 1939 war, this "New Carthage" would provide many interesting topographical features. The territory of Tunisia is a strange combination

of desert, oases, and mountain plateaus. In the northeast, the temperature seldom goes over 90. But near Tunis proper and along the Sahel coastal country, burning sirocco winds often blow in from the desert, bringing extreme heat and blinding dust.

Westward from Tunis stretches a region dotted with what are known as *shotts*—depressions which in the wet season may become lakes. As they begin to dry up, these *shotts* become impassable quagmires, then they eventually harden so that men and vehicles can pass.

All these things will have to be considered in any modern war staged in Tunisia.

There are many fine and valuable harbors in Tunisia, as there were in the days of Carthage; and today the French Navy has placed its main Naval works and an arsenal at Sidi Abdallah. Then there is Bizerta, which boasts splendid shipping accommodations. Here there are shipyards, a dry dock, a submarine base, and an air base. This set-up, according to inside information, is backed to no small degree by the British, who continue to keep one eye on their Mediterranean life-line.

A French Resident General controls Tunisian finances, commerce, public works, and foreign affairs. But a native Bey, titled as Regent, otherwise rules the land. Meantime, the French Government has extended the jurisdiction of the local native councils.

French army posts are scattered all over the country. But to a great extent, the troops are natives under French officers. The Tri-Color has been openly rushing Tunisian fortifications because of the new threat from nearby Italian Libya. And reports have it that a minor form of

(Continued on page 73)

Roman Legions — this time swift "Legions of the Sky" — may once again lay siege to that historic African stronghold long famed as the "Queen of the World." For Mussolini is already acting out his dream of a new Roman Empire.



The Clue of the Breda Brood

By Arch Whitehouse

Author of "Vultee Vortex," "Trans-Jordan Tracers," etc.

Illustrated by Alden McWilliams

"IT'S TAKING A CHANCE," Brian "Coffin" Kirk muttered, "flying a stolen foreign bomber-fighter this way. And having no registration and no papers is asking for it. But when I tell them what happened up there at Dulit, the Governor ought to do something about it."

Behind Kirk, curled up in utterly exhausted animal sleep, lay Tank, his flying and fighting ape-pal. Tank had drawn the hatch cover shut and was reasonably comfortable, and Kirk knew he could rely on the gorilla if anything turned up.

Kirk's route followed the coastline up past Barham Point and across Kinabalu Peak to Sandakan, which lay on the other side of Lubuk Bay. The speedy Heinkel would eat up the distance in two hours or less.

Ahead lay safety, rest, and officialdom tinged with warm friendship for Kirk, who almost single-handed was fighting the diabolical ring of war mongers known as the Circle of Death. And Coffin was still congratulating himself on his amazing luck in escaping from his last adventure with the agents of the Circle who had trapped him in the grim lethal chamber of old Dulit.

"Old Cockosaert, their leader, got away in one of these Heinkels," Kirk thought. "I wonder what the devil they will be up to next?"

The feud between Kirk and the bloody Circle of Death had been raging since twenty years before when Kirk, then a mere child, had escaped, with the aid of a trained ape, from the Berlin zoo where his father, an American espionage agent, had been cruelly betrayed and shot down in cold blood. It was that crimson-stained scene that forever flickered in the memory of Brian Kirk and prodded him on against bitter odds to win revenge for the man who had sired him.

Again that scene flashed before his eyes as he caught the outline of Lubuk Bay in the velvet half-light of the Borneo night. He drew his features into a mask of hatred. The Circle of Death had now swept its scimitar into the Far East.

"I wonder where that murderous Belgian will head for now?" Kirk pondered. "He said

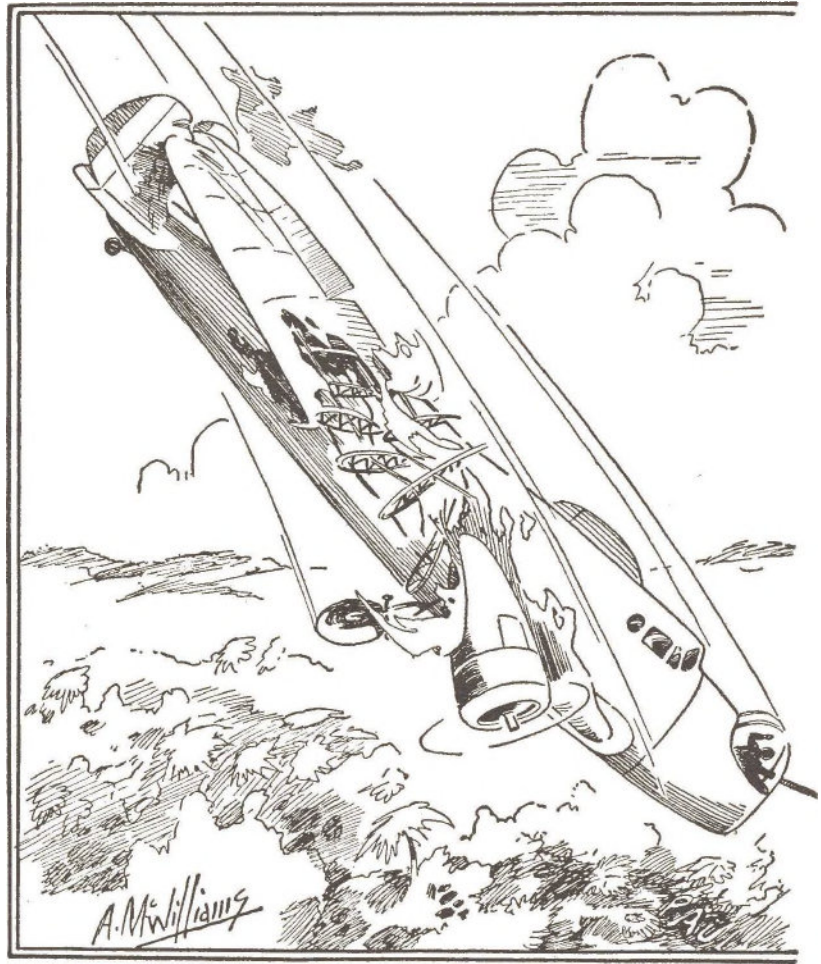

something about captured Dutch tankers. But it's dollars to dingbats they'll try something else—even though we managed to block off their fighters."

THE HEINKEL was approaching Sandakan now, and Kirk forgot the Dulit affair to consider his landing and the explanations to come. As he circled the city, throttle back a notch or two, "Coffin" again thought of the description of Sandakan he had gleaned from his studies. He repeated to himself the information bearing on this tropical center.

"There are 13,000 people of various races, creeds, and color in Sandakan, and Sandakan is located more than 10,000 miles from the seething center of strife-ridden Shanghai. A small detachment of British and native constabulary maintain peace and defense for the territory of British North Borneo. And," added Kirk, "they are helped along with their Lee Enfield rifles and Lewis machine guns.

"There are nine wireless stations in the region," the reports had stated, "a state bank, and two British Residencies. The commerce amounts to less than ten million dollars a year, but Sandakan is important because of its geographical position in relation to the Philippines, Singapore, Hong Kong, and Australia. And several of the Democratic powers are interested in the safety of British North Borneo, although most of them would officially deny it . . ."

With that much remembered, Kirk circled the north side of the city, and his eye followed the main line of lights which ran southwest toward the open country beyond. He had been

Swiftly, silently, and unseen that weird, nameless scourge swept upon Sandakan, Britain's North Borneo outpost. Then lights failed, radios went dead, and planes became useless hulks of fabric, steel, and dural. That meant banishment from the air for "Coffin" Kirk. And now, as he faced the dread jungle which had spewed this strange sorcery, hate boiled in his heart. For "Tank" — faithful "Tank," his steel-muscled, simian body-guard—had been swallowed by that green hell!

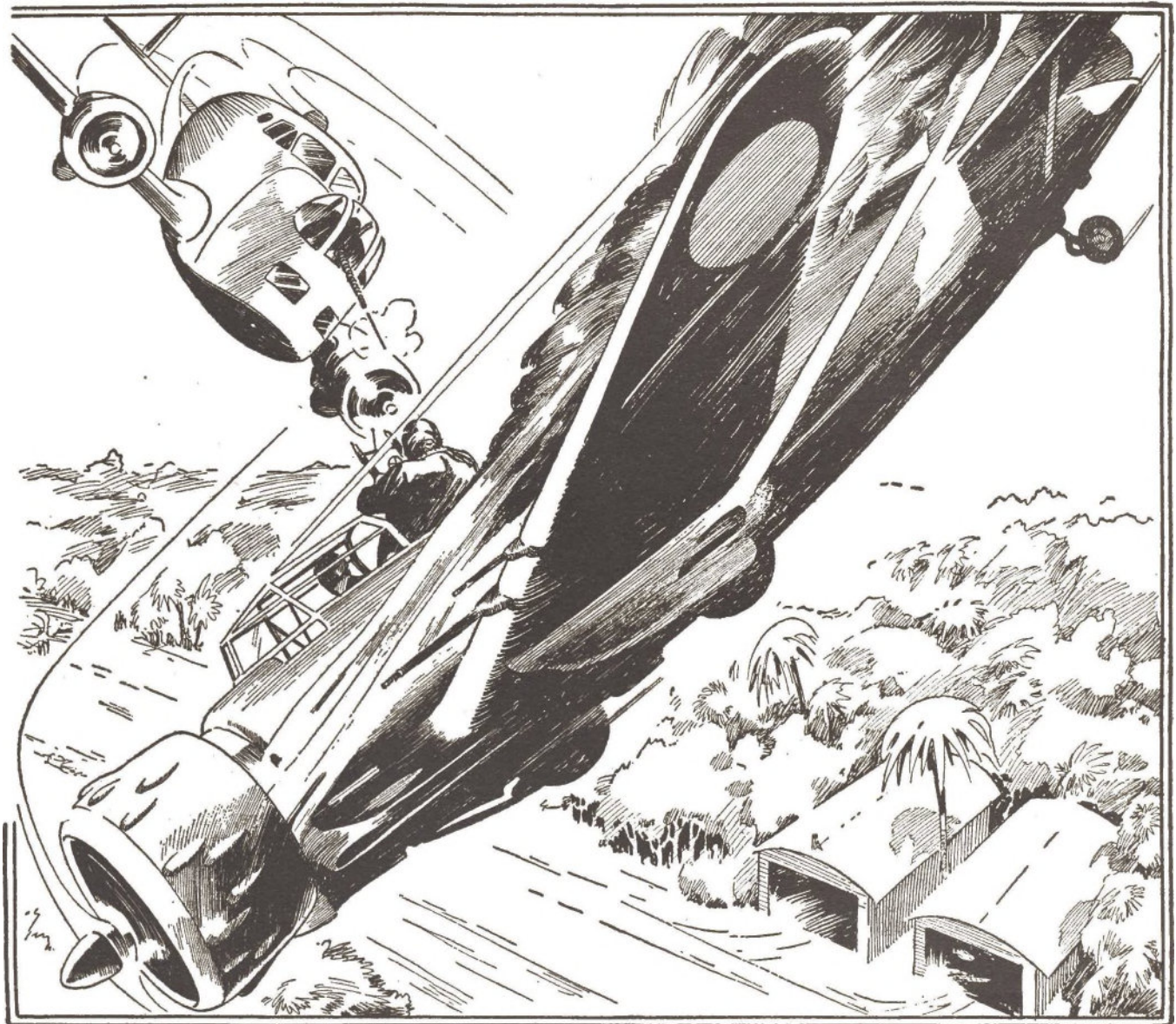

With a scrawnch of ripping members, the starboard wing of the first Fiat buckled. But then, before Kirk could swing around, there came the sudden shock of battering Safat lead—and their Breda was in flames!

advised in Singapore as to where the new R.A.F. field was located, and he was making a mental map on the end of the line of lights to figure out just where the air-drome lay.

But just then the faint thud of concussion caught the stolen Heinkel and made her wing-tips dance. Kirk was all ears and eyes. Then he glanced down again and discovered that all the lights below had been suddenly extinguished!

"Queer!" he muttered. "Some defense measure I suppose. Since I haven't reported in they're taking no chances."

Kirk looked about the cockpit for a radio set, but he had not been aboard long enough to completely familiarize himself with the layout. He circled the city again, trying to figure the German lettering on the panels of the speedy fighter-bomber. And even though he was well versed in the language, he took several minutes in selecting the right switches to put the set in action.

Then he called the station ZGW—a temporary designation given to the R.A.F. headquarters station there—but got no answer.

Kirk frowned a little at that and started to call again. "Something queer about this. Hello! What are those flashes down there?"

But concussion again caught up with him—and now he knew.

Bombs!

Sandakan was being bombed! Some one was dropping "eggs" on important points of the town! The Circle of Death, perhaps . . .

"Come on, Tank," Kirk bellowed over his shoulder. "Get up, you lazy rascal, and keep your eyes open."

It was well that the simian reflexes of Tank responded. Kirk had sensed that something was wrong, and during the few minutes in which he had been vainly attempting to get in touch with the R.A.F. field somewhere below, Fate was bearing down on them out of the Borneo darkness.

The hunched figure in the back seat uncoiled, rubbed a hairy hand across his broad nose, and sniffed. He shot a preliminary glance at Kirk, and then instinctively moved toward the Krupp-Spandau movable gun grip.

INSTINCT, that blind mode of action, came to Coffin Kirk's aid in the next split-second instant. He gave the control-column a nimble twist, flushed the rudder over, and pressed against his belt as if to urge the Heinkel to faster speed.

As the fighter-bomber came around, two forked spurts

GRIPPING NEW "COFFIN" KIRK SKY MYSTERY

of flickering tracer light flashed overhead and spanged against the upper wing-tip. Tank responded with a low jungle growl and yanked the gun out of its cradle.

"Wait a minute," ordered Kirk. "Let's first see who they are."

Tank blinked, pawed at the gun again, and looked up toward the winged thing that spat death at them. Then he ripped the Krupp gun around, took his usual wide-eyed bead, and fingered the trigger.

"Wait a minute," Kirk warned again. Then he ripped the Heinkel around so he could get a better view of their attacker. He fully expected it to be another Heinkel, but it turned out to be an Italian ship.

"Hello! A Roman this time. Looks like a new Breda 65."

The jet-black ship was a two-place, low-wing with a folding undercart. In the nose—ringed in with a deep circular cowling—was an 850-h.p. Alfa-Romeo engine. Not a super-speedster this ship, but a neat piece of equipment for bombing, combined with excellent maneuverability and get-away. Kirk took all this in as another splatter of tracers fanned down at them from four 7.7-mm. guns set in the leading edge of the Italian plane's full-cantilever wing.

"That baby can be flown like a single-seater," Kirk yelled at Tank, who was still fingering his gun with sleepy anticipation. "Let him have it, fellow!"

The simian crouched over the spade grip, pulled the trigger, and held the gun steady. Kirk watched, treadled the rudder, and brought Tank's fire dead into the nose of the black raider.

"That made him twist," cried Kirk. "Hold it, Tank!"

The black Italian bomber swung away as if startled by the sudden opposition. Kirk took advantage of the opening, hoiked the Heinkel up, snapped her over hard, and came around at the Breda and opened fire. Tank's great paws were on his shoulders as he drew the bead. There was only one heavy caliber Spandau-type gun under the Heinkel's hood, and Kirk knew his aim had to be true.

Brat-a-tat-tat-tat-tat-tat-tat. . . !

The single streak of fire spat out like a javelin from hell. Vibration rattled along the metal framework of the Heinkel and Tank danced with animal glee in the rear pit.

"Got him! Smoking already!" Kirk called as Tank jabbered excitedly.

The Breda twisted in agony and tried to evade the torturing fire that engulfed the ship in a shroud of death. There seemed to be smoke coming from the Italian ship, but it was only faint in the glare of the flame from the Breda's exhaust.

"That's queer," reflected Kirk, giving her a final burst. "I'll play safe. He may be trying to gas us."

The Breda was out of control now, slipping and sliding off on one wing. Instinct again seemed to warn Kirk, and he drew clear, but kept the Italian ship in sight.

"There's something screwy about this," Kirk muttered, as he kept distance from the floundering bomber. "He's going down all right, but there's something queer in Scandanavia."

The Breda fell off and dropped into a slippery spiral. It was evident that she was definitely out of control, but they followed it down until it struck into a jungle copse near a great spraying waterfall.

"That should finish him," Kirk reflected as he circled again, waiting to see if the wreckage would burn.

THEY swung around twice, but no answering signal of flame came up. And Kirk had to be satisfied with the realization that no plane could land safely in a dense growth like that and get out again. He made a quick check-up on his map and figured the Breda had

gone down about ten miles southeast of Sandakan.

Tank now had the hatch open and was leaning out into the slip-stream. He looked down and made strange noises through his nose. Kirk leaned over, lugged the ape inside, and made him put the hardware away.

"Well, that was that," Kirk said to himself, audibly. "Now we'll find out why those lights went out and what all that bombing was about."

Kirk put the Heinkel into a climb again and headed back for the Borneo city, wondering how he was going to find the field without the aid of ground lights. He decided to try the radio again, but the thing only spluttered and died cold.

"That's queer. *Everything* is out now!"

He fumbled with the set for a minute or two, then realized that the motor was turning over unevenly. Kirk made a quick adjustment on the Daimler-Benz throttle, but the spluttering became more pronounced. Even Tank sensed the tension and peered over Kirk's shoulder.

"He didn't put a burst into us this close to Sandakan, did he?" asked Kirk, as if he expected Tank to answer.

The German engine did not respond to any mixture adjustment. Kirk switched over to another tank, tried again. The spitting and sputtering became worse. He stared about with a helpless grimace. He wished they had parachutes.

The spluttering now became still worse and she started backfiring through the carburetor. There was a final cold explosion, and the engine quit dead!

"Okay. Here we go, Tank. Bundle up and get ready for a crash."

Kirk peered over the side and sought an open stretch of ground to pancake on. But the earth below was a dull gray patchwork of nothingness. Then without warning something blazed out below that appeared to be a landing signal.

"Looks fairly good down there," he argued to himself. "Sure—it's the field. I can see the hangars now. Damn camouflage almost fooled me. But they've got a flare out for us."

He brought the Heinkel around in a wide circle and made his approach in the direction of the smoky blaze that appeared to be set up in the middle of the field. The controls were going lopy now and he had to wrench the ship about hard to get any action. He worked on the pneumatic undercarriage gear to get his wheels down, and he let out a sigh of relief when the red light on the dash finally changed to green indicating the carriage was in order.

The field was clear to his vision now, and Kirk was satisfied that he could get in safely—engine or no engine. He banked into the wind and let her ride gently. Then for the first time he realized that the blaze was not a landing flare at all, but a burning plane!

"Whew!" gasped Kirk. "What a night!"

The Heinkel floundered over the billowing heat from the burning ship and Kirk nosed her down, felt for the wheel brakes with his heels, and then waited for her to touch.

The Heinkel stabbed at the earth once, dug in hard, floundered into a dull balloon bounce, then dropped back with a metallic thud. Before Kirk realized what was happening the bomber-fighter came to a sudden stop, dipped her nose—and went over on her back.

That was all Kirk remembered.

COFFIN KIRK awoke sometime later with a clatter in his skull like that of blacksmiths building rock-er-arms. Some one seemed to be letting skyrockets off under his nose, and his eyes were peering into a crazy-quilt maze of light. Finally, it all cleared and he shook himself into some degree of sanity and stared about him.

Heavy legs, greasy tropical shorts, red hands, and businesslike belt buckles made up the lower portion of the cyclorama before him. He raised his eyes a trifle and noticed a ring of broad chests and khaki shirts upon which were stitched murky decoration ribbons and R.A.F. wings. Farther up were tanned necks, sturdy chins, and faces that bore official frowns—and grease.

(Continued on page 61)



Through the Aero Lens



Under the British term "medium bomber" this Bristol Blenheim, now being supplied to the Royal Air Force in large numbers, is vaunted by the Englishers as the fastest machine of its class in the world. A low-wing, full cantilever job, the Blenheim is powered with two Bristol Mercury engines. It has a service range of well over 1,000 miles and an official top speed of 279 m.p.h. Indeed, some reports have it that the Blenheim can do 285 m.p.h. at 15,000 feet! Observe the "frog-nosed" prow of the plane, also its sturdy retractable undercarriage.



This German Henschel 123 fighter-bomber has a top speed of 225 m.p.h. and a range of 600 miles. A two-placer designed after the earlier 122 general-purpose job, it's equipped with spats, spinner, a three-bladed prop, and a sliding hatch over both cockpits. Reported as an export model, it may be seeing service with some South American air force within a short time.

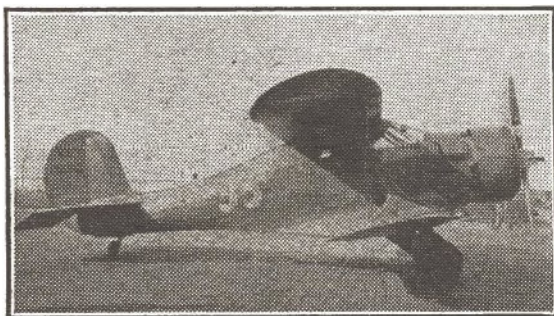

Here's a shot of Jackie Cochran's Wasp Jr.-powered Beechcraft which was flown by Max Constant in the recent New York-Miami Air Race. In case you didn't read about it, Max roared it home to first place, too. Jackie, you'll remember, used the high-speed Seversky AP-7 when she copped first honors in the 1938 Bendis race—so maybe she's forgotten she even owns this Beechie.

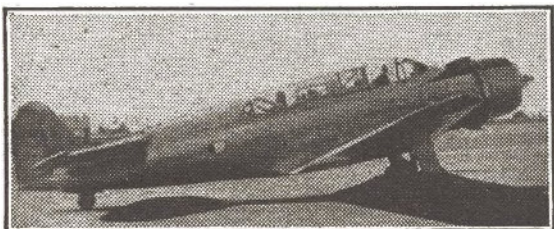

Vultee has now again attracted all aero eyes, this time with an improved model of the V-11 shown above. Tagged the V-12, it's a Twin Wasp powered job which we understand will be offered in the export market as either a three-place bomber or a two-place attack ship. As a bomber she turns in 222 m.p.h.; as an attack job, 247 m.p.h. at 19,000 feet.

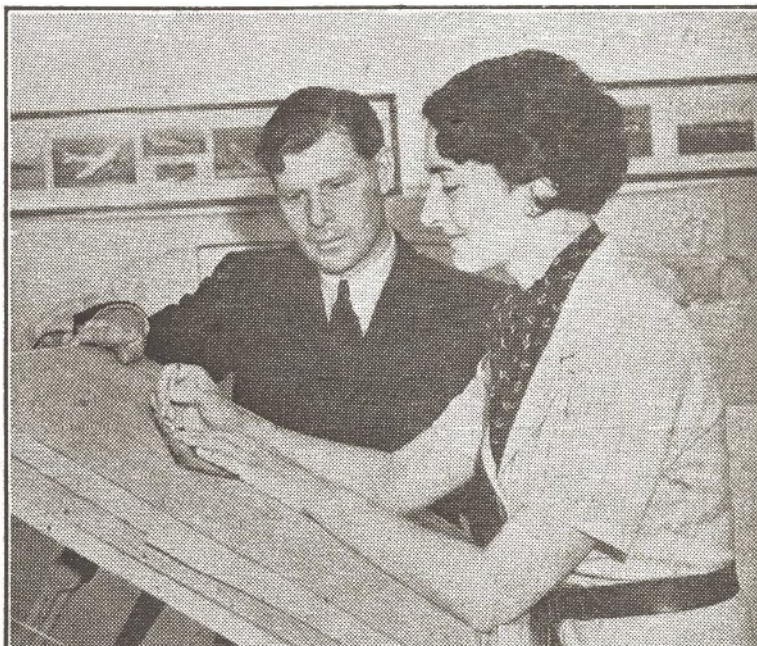

You've surely heard tell of that young wizard named F. G. Miles—the fellow over in England who's turned out that sweet series of ships which includes the Miles Falcon, Magister, Mohawk, and all the rest. Anyhow, maybe the secret of such success lies in letting one's attractive wife take a hand at the drawing board. But all kidding aside, Mrs. Miles HAS been a mighty big help to her husband in his work. FLYING ACES is pleased to introduce this famous couple to you here.

Right: This scene, taken inside a compartment of the huge 74-place Boeing 314, is the sort of thing that makes the oldsters of aviation weep. For it proves that flying is becoming more nerve-tingling and risky every day, doesn't it? Yep, it certainly doesn't! And Harold Mansfield, of Boeing, tells us that those davenport-type seats "are deeply cushioned with a special pillo-woy substance made of curled and rubberized Australian horse hair." What, oh what, will the barnstormers of yesteryear say to that? Altogether, now—let's bust out into a good old cry. The old days—are gone!



On the Light Plane Tarmac

NOTES ON THE YOUTH AIR MOVEMENT

TRAINING FOR THE LUCKY FEW?

FOR YEARS, we of FLYING ACES have been staging an almost continuous campaign in this department urging that a "break" be given "the young man in the street" who wants to fly.

In the early years of this effort, we were probably more enthusiastic than efficient. We simply kept singing the chorus about getting people into the air. Exactly how it could be done was a somewhat hazy question.

Still, as the years rolled by and we carried on through the aviation doldrums that followed 1931, the picture became a little more clear. By that time, we had managed to sift through many piles of monthly mail from our readers and found out just what it was the average aviation enthusiast actually wanted to do most of all.

It's quite true that many of our correspondents had ideas about joining the Army or Navy Air Service. Quite a few, too, pictured themselves at the controls of modern airliners. There was a time there, also, when the Border Patrol had a grand following, and then it was the Coast Guard. What's more, certain features in our magazine brought a lot of fellows to hanker after test piloting and trans-ocean flying.

Well, all that's perfectly normal. There's a little bit of Robin Hood in all of us. We like to imagine ourselves in the rôle of some popular legendary character. We all go for the King Arthur yarns. We canter the London-to-York road with Dick Turpin, share a flagon of meade with Mad Anthony Wayne, and draw a bead over a squirrel rifle with Daniel Boone.

In other words, we all secretly yearn for deeds to do as individuals—deeds in which something or someone is defended, the poor are protected, and right goes trampling over might.

This type of "yen," no doubt, is the basis of true patriotism. Those who have it play stirring parts in national defense—often with no desire for reward in the form of either pay or rank.

Today these people want to fly—not necessarily in the trim formations of the Army or Navy, but simply to satisfy a spirited urge. And these are the people we have had in our mind ever since we started to do pieces in favor of some scheme that would enable a lot of people to fly safely, cheaply, and as often as they desired. We have continued to believe that the more people we can

get into the air, whether as amateurs or professionals, the better prepared will be our country should an emergency arise.

It was with profound satisfaction, then, that we read President Roosevelt's statement that something was going to be done, through the National Youth Movement, to teach several thousand suitable persons to fly under official Government supervision. Our heart was lightened. This was the real thing!

But then came the rude awakening. From Congress on down the plan took a panning. Certain aviators blistered the newspapers with criticism. Fearing competition, some of the small flying school owners let out a squawk that scared the polar bears up in Greenland. Some of the arm-chair defense experts loosed a barrage to the effect that the plan was screwy. And most of us who had been suggesting the idea scurried for bomb-proof shelters to evade the explosions.

The thing is that no scheme, however clean of line and intention, will satisfy everyone. Anyhow, our guess is that the anti-plan aviators, who live on the headlines of their deeds, don't want everyone to fly simply because as soon as a lot of people take to the air, that same lot of people will realize that there is nothing much to it. That, in itself, would whirl away the halos that many have placed on the air heroes.

The squawk of the small flying school operators is that for years they have been hanging on to a slim existence and that

now when the masses are to be taught to fly, they will get no part of it because all the flying will be done at the bigger fields. It's tough, too.

Meanwhile the long-suffering ordinary chap figured the move would finally enable him to go to some nearby field and get flight training. But when he actually read the details of the plan, he discovered that it was the college guy who is to get in on the free flying—not the \$25-a-week lad who for years has had his eyes aloft with the hope throbbing through his veins that some day he might actually get the opportunity to win a pilot's ticket.

It's true that G. Grant Mason, Jr., of the C.A.A., recently pointed out that this program should not be considered as "the whole story." Nevertheless, with all our digging we've been unable, at this writing, to find any contemplated provision for flight training for the non-college "young man in the street." And that's a damn shame!

APL OFFERS PROMISE

PERHAPS there is some hope in a new organization that has been brought to our attention. Perhaps we need something more than a lot of blasts in a magazine. Perhaps we need some sort of an organization where actual flesh and blood plays a part, rather than paper and printer's ink.

The Airplane Pilots League has temporary headquarters at 516 Fifth

Training For the Lucky Few?

APL Offers Promise

"I Still Rent Mine"

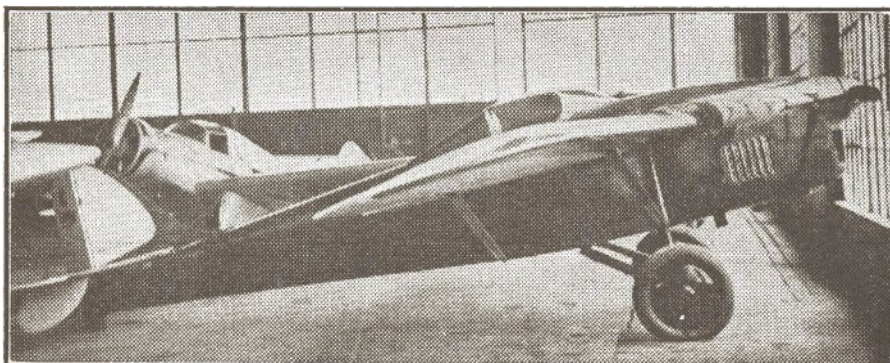

Looks like a nice little job, huh? It's the new Babcock Skymaster just produced by the Babcock Aircraft Company, of Akron, Ohio. Sleek lines, a covered cockpit, and inverted Menasco power are featured.

Avenue, New York City, and within a short time it will have offices in Washington, D. C.

At present it is composed of a group of pilots headed by John L. Scherer, a well-known aviation editor and aero columnist for the Rochester *Times-Union*. Jack, as we know him, is being assisted by Stanley Gerstin, another flyer-writer.

Anyone holding a student pilot's permit or any higher flying license is eligible for membership. The APL is not connected with any magazine, it is a non-profit organization, and every member has a vote. The dues of \$1.00 per year includes a membership card and a suitable lapel wing pin.

The object of the APL is to unite the 40,000 student pilots and the 21,000 licensed pilots into one strong organization so that they can effectively combat adverse or restrictive aviation legislation, achieve modification of several present laws which are very unpopular with pilots, and co-operate with the Civil Aeronautics Authority by acting as a go-between for the Authority and the private pilots of the nation.

The APL also favors the creation of a Civilian Air Reserve which would be fair to operators of both large and small flying schools and to holders of pilot licenses as well as to future pilots. According to Scherer, some of the plans now proposed by the C.A.A. call only for aid in getting new pilots—to the neglect of present certificate holders.

That there is a need for such an organization will readily be seen when it is realized that the largest aero organization in the country which accepts flyer members has a roll of only 2,500 pilots. This can hardly be considered a representative organization of flying men.

The APL has hopes also of sponsoring a "little National Air Races" which would be open to non-professional skymen.

We believe that many of our readers will be interested in the Airplane Pilots League, thus we have offered this information in event you fellows want to give it a further check.

"I STILL RENT MINE"

THIS MONTH'S prize letter comes in a somewhat roundabout way, from a fellow who is a friend of ours. We were talking to him some time ago on the way down to Heights-town, N. J., where we tried out the new Piper Cub powered with the 50-h.p. Franklin motor. Anyhow, this lad is our idea of a real light-plane pilot. He has a number of swell things to tell you about the problems of flying a sport craft—particularly a rented one—and we are more than pleased to welcome his letter to the Tarmac and let him take two bucks.

Light Plane Editor:

I'm an average (I think) pilot—and I'm still wandering from field to field *renting* my airplanes. I have had some very enjoyable contacts in this way with a few of the good operators in aviation, of which I believe there are all too few. And I have refused to fly at some of our so-called business fields.

Anyhow, the feeling has come over me that there must be quite a number of pilots in the

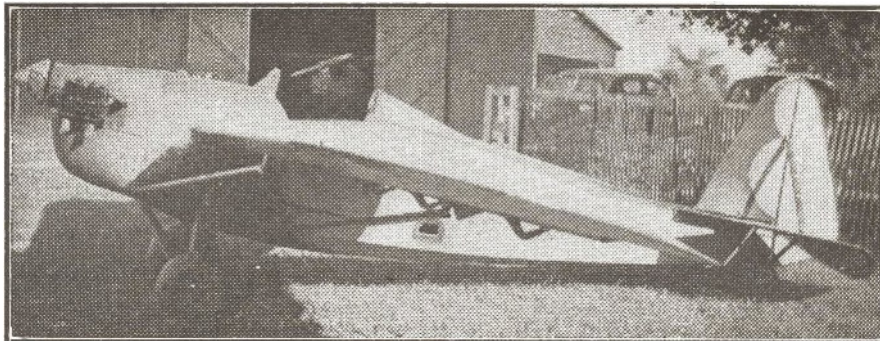

Down through the years has come the Heath firm. And here we see the company's latest sport craft. Dubbed the "Experimental Bullet," it employs a Continental power plant. The factory, incidentally, is now located at Benton Harbor, Mich.

same state of mind as I find myself—well along in hours and with a certificate of competency, but not quite ready for my own ship, though still wanting to fly in the meantime. If such is the case, they must look on the situation much as I do.

Have you ever driven to a field with the urge for a hop and deciding that if the set-up looks right you'll rent a job for an hour or so and just fly for sheer fun? I have lots of times. But too often I have seen only one ship available—and that one getting its routine check, even though it's Saturday or Sunday! Having been to several airports on week days, I know very well that the planes could be checked earlier without straining the schedule. Why, in cases like these I have been asked to help gas and service a ship! Of course, I'm not above it. But I came out to fly, not to work.

And have you ever wanted to go cross-country in a rented bus? Well, most of the operators just plain don't
(Continued on page 78)

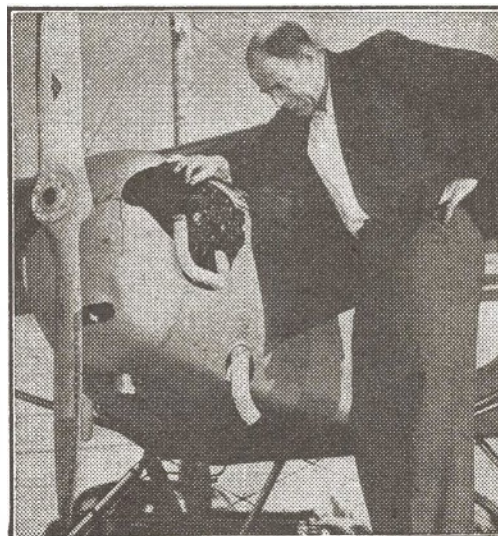

A winner and his ship—Dewey Eldred, of Willoughby, Ohio, and his neat Taylorcraft seaplane! Flying non-stop from New York to Daytona, Fla., on January 7, Eldred set a new international record for light float-jobs by covering the 902-mile distance at an average speed of 71.1 m.p.h. On the right we see him admiring the 50-h.p. Lycoming engine which buzzed his ship down the coast to set the new standard. And below we get a nice view of the Ohioan taking his Taylorcraft off Biscayne Bay during demonstration flights in Miami.

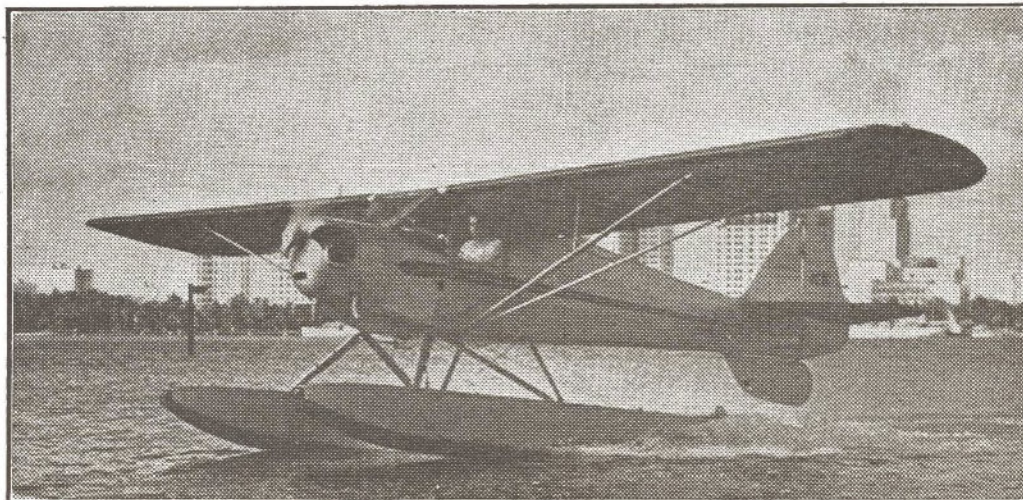

All Questions Answered

This section of **FLYING ACES** is at your service. So if you have an aero query, fire away and we'll answer it here. All questions will be considered in the order they are received. For a personal reply, send stamped, self-addressed envelope.

Ken Brindal, South Australia:—The Fairey Battle has a top speed of 257 m.p.h. and a span of 54 feet. The clipping of the plane you sent in is that of a Douglas DC-2. Glad you have liked our "Conroy" feature.

Donald Buckberry, Romulus, Mich.:—So you want to contact any **FLYING ACES** reader who has the model plans for the Douglas O-46A observation ship and the North American O-47A? Perhaps some of our readers can straighten you out.

Billy Jacobs, New York City:—The drawing you sent in is of a French Morane Parasol, a high-wing single-seater used early in the World War by both the French and the British.

John Hezlip, Carlinville, Ill.:—I believe you can still get compressed air motor parts at the Cleveland Model and Supply Company, 1866 West 57th Street, Cleveland, Ohio.

Cleon R. Newman, Corning, N. Y.:—The roll of drawings you sent in are very interesting and show some talent. But they are not suitable for reproduction as they now stand. Technically correct drawings call for the use of drawing instruments and suitable paper for the work. Air story illustrations must also have drama and action to build up the plot. Cover scenes demand even a finer type of work. You have a good foundation, but you require more actual experience and study so that you may learn the various problems of the game.

T. Osato, Chicago, Ill.:—Your lengthy letter received recently concerning our charge that the Russian armies of the World War were not among the greatest is most interesting and your compilation of Russian victories give evidence of your sincerity. However, you cannot ignore the series of events that led up to the Treaty of Brest-Litovsk. The list of victories you have drawn up is Okay in one sense. But none of them were major conflicts. And blaming the big defeats on lack of ammunition and dirty work at court, does not wipe out the fact that the Russians were soundly beaten.

Milton Mitchell, Milwaukee, Wis.:—Frankly, I know of no book that will teach you to fly. You must learn by actual flying. You can get much fine information, however, from Assen Jordano's book *Your Wings*.

Fred Compo, Ballston Spa, N. Y.:—We are always open for new aero jokes.

Address **Wisecrack-Ups**, care of this magazine. First, however, read the note at the top of the **Wisecrack-Ups** page in this issue.

Leo Marcus, Woodhaven, L. I.:—Yes, I wrote the article you referred to in your post card communication. I suggest that you consult Hamilton's *Complete Model Aircraft Manual* for the answers to your questions on model airplane design.

J. A., Hood River, Ore.:—I would suggest that you first check with a competent Government physician before you give up hope concerning your physical condition for military aviation. Not being a physician, I cannot make a statement regarding your case.

Abraham Gisser, New York City:—Your suggestions concerning the manner of building up the air services are all very good—except that you ignore the fact that this country only has about 36,000 skilled workers who can build modern planes. When we have about 100,000 such workers trained, the chances for improvement will be much better.

Dan Williams, Gadsden, Tenn.:—Many thanks for your Christmas card. Dick Grace can be reached through the

batros, as the magazine you clipped it from states. The Albatros triplane had small double struts, not single interplane struts. So you are right.

Pat Blackledge, Laurel, Miss.:—The actual official figures on the Hurricane and Spitfire are: Hurricane, 335 m.p.h.; Spitfire, 355-plus m.p.h. The 355-plus figure was given out on the Spitfire at the recent Paris Aero Show. It indicates, of course, that the job does better than 355. But how much better, we have no idea. Unofficial figures, though, are 375 m.p.h.

Bill Colley, Riverside, Calif.:—I know of no plane called the Grumman Hell-diver. The insignia of Major Garrity's Ninth Pursuit is a mystery only Joe Archibald can solve. Actually, however, the Ninth Squadron during the World War was a night-observation outfit, and today it is an airship squadron. The insignia for the latter is a triangle made up of three elongated links inside which a rising sun is shown against a horizon of blue background. You have a good idea in that new Black Bullet design and we'll have to buzz over to Long Island and see if we can work it out with Barney O'Dare. Maybe he could sell his boss on it.

George W. Hering, Hales Corners, Wis.:—The new Allison 2,250-h.p. engine is still under test and not ready for installation, as far as I know. It is a 24-cylinder plant using four rows of six cylinders each mounted on an oval-shaped crank-case. The Cunningham-Hall GA-36 was not a military model. It was a two-place monoplane powered with the 145-h.p. Warner Scarab engine. The Bell Fighter is not in service as yet, and I have only just learned that the air-cannon to be fitted are something special designed by the Army Ordnance Department. Beyond that I know nothing about the weapons. There are no further details on the French Delanne, either. It was not on display at the Paris show, so it apparently is not ready for display or performance as yet.

Robert G. Shaw, Victoria, Australia:—Static balanced ailerons are those balanced through leverage to a small mass weight which makes it easier to move the control surfaces. They will be noticed as small streamlined weights mounted on a short rod above the hinge line of the elevators or ailerons, as the case may be. The pitch angle of a prop is best defined as the angle which the chord of the blade section at any particular place makes with the horizontal
(Continued on page 26)

And Now We'll Ask You a Few

- 1—How are "plastics" to be included in the manufacture of airplanes?
- 2—What is a sirocco?
- 3—What was the Fairey "Flycatcher"?
- 4—Do German fighting planes use automatic gun turrets?
- 5—What is the Bergamashi A.P.1.?
- 6—Who wrote the book *Some Still Live*. And what is it about?
- 7—What is the horsepower of the latest British "Dagger" motor?
- 8—Can cities be bombed with poison gas from the air?
- 9—How can ice conditions stop the motors of an airplane?
- 10—What is the meaning of the word "aerostation"?

(Answers on page 80)

publishing office of Doubleday Doran, Garden City, Long Island, N. Y. The book *Strategy and Tactics of Air Fighting*, by Oliver Stewart, is one of the best technical works on air warfare I know of. Your bookseller can get it for you. Orville Wright is still very much alive.

H. E. Seibert, St. Paul, Minn.:—The triplane shown in that picture of the memorial to von Richthofen is most certainly a Fokker triplane—not an Al-

HAPPY LANDINGS

BY ARCH WHITEHOUSE

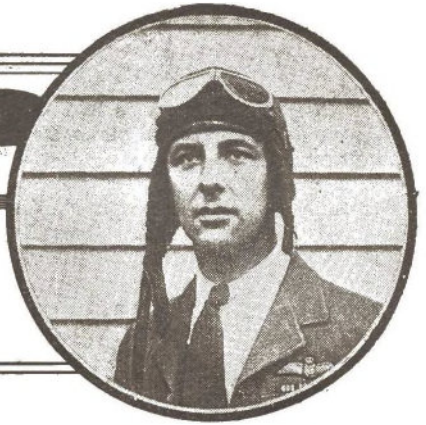
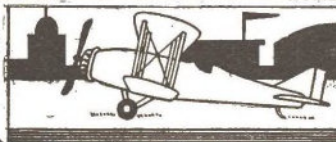

“Plan For 20,000—But Plan For 'Em Right!”

* * *

LET'S start off with three questions: Would you care to become one of the 20,000 pilots to be trained by the United States Government? On the military score, do you realize what it takes to become a military pilot? And do you know the actual percentage of successful candidates, who actually pass the Primary Flight Training course at Randolph Field, our “West Point of the Air”?

You do know, of course, that if President Roosevelt's plan is accepted a sum of \$10,000,000 a year will be provided to train 20,000 young men as civilian pilots. And we take it for granted that in case of an early war most of these men will be automatically taken into the squadrons of the Army or Navy Air services.

Incidentally, Dr. George Gallup, the gentleman who runs the famous American Institute of Public Opinion, has “sicked” his survey corps on the American public—and he's discovered that 87 percent of the population favors a sky training plan while only 13 percent put thumbs down on it.

Now then, add *this* striking fact to the layout of figures: The records at Randolph Field disclose that out of the 300 or so accepted as candidates for flight training each year, only about 51 percent actually stand the gaff of this tough course and get by. It must be understood, you know, that the original 300 had already passed their educational and physical training tests. What's more, those proving themselves able to “take it” at Randolph still face another course at Kelly Field!

In short, the fact that a war-scared Government is willing to donate \$10,000,000 a year will not produce 20,000 first-class military pilots. The kind we turn out at Randolph and Kelly are not made on money alone.

“But wait a minute,” you say, “This is a civilian flying program.” Our answer to that is: We know it—but nevertheless the factor of building up potential air force material is very much the moving motif of the scheme. And that being the case, it's well for us to keep it strongly in mind.

Now what means will be taken to select these 20,000 would-be pilots? What precisely will they sign up for when they accept this training? What personal protection will they get? And what will happen to them once they have learned to fly?

Are the candidates to be selected entirely from the college crowd—or will the plan be broadened to give the high school fellows a “break”? Will the training go beyond the simple rudiments of training-plane flight, or will it include a certain amount of time on not-quite-obsolete service planes? Is it possible that the candidates will complete this training and then find themselves members of the U.S. Army or Navy and under the complete jurisdiction and formal discipline of these services?

Exactly what happens in Europe during the next few

months will have a bearing on this last important point. We would like to know in this event, just what the status of these candidates will be once they have put their names to the applications. Will they be *bona fide* members of the national defense? Will they be considered in the same light as the 1917 soldiers who “signed up for the duration” and as such come into the same classification as enlisted men who can be shunted about, ordered hither and yon, and rushed into any branch of the service from Tank Corps to the Engineers?

We of FLYING ACES feel that we have pioneered in this “20,000 pilots and 8,000 war planes” business. We began to point out the need for such expansion nearly ten years ago because we had a little foresight. So when all the other aviation magazines were overabundantly cheering the trans-Atlantic heroes, the wonders of the Ford trimotor, and the growth of commercial aviation, we in our lonely voice were trying to draw attention to the fact that something should be done about our air forces.

But no one seemed particularly interested in the Air Services in those days. And whenever we so much as suggested that foreign powers were going ahead in the matter of high-speed fighting ships, we promptly got a slew of letters telling us to forget about war. “Instead,” they said, “get people to paint the names of their towns on their barn roofs.”

SO NOW, after the idea has at last percolated into the nogginns of the Government, they are scaring us to death with the immensity of the plan they hope to put over. Is it any wonder, then, that we're afraid all this will be carried out in slipshod, over-night fashion? We remember full well the boasts and statements made in 1917 when the United States entered the World War. Initial high hopes and glorious promises frequently collapsed. Seven hundred million dollars and a whole year of time were wasted, whereupon our great resources, wonderful engineering skill, boundless enthusiasm, and high-voltage energy were as nothing—because the system too hurriedly planned, then unsoundly executed.

Today, they want to train 20,000 good civilian pilots in double-quick time, seeming to forget that an Army Air Corps Cadet under normal conditions can get but 90 minutes of flying per day for a full year and even then is not considered first-line material. Let the reader understand that we realize that 20,000 pilots will be needed, make no mistake about that. But before diving into the deep end, the promoters of the plan should check, re-check, and re-re-check to make sure they've got their scheme actually drafted in can't-miss style.

Since we've stuck our chin out this far, we'll now make an attempt to approach the problems involved: First, insurance should be sponsored by the Govern-

(Continued on page 79)



All Questions Answered

(Continued from page 24)

plane when the airscrew is laid flat on its boss on this horizontal plane, its axis being vertical.

K. A. Rides, Christchurch, N. Z.:—I have no record of the first actual use of the seaplane catapult aboard a cruiser, so I can't answer your query, although the clipping you sent me is very interesting. I have looked this subject up from many sources, but no one seems to have bothered to list the first naval catapult take-off. Perhaps some of our readers have a clue to this mystery.

William Bowen, San Antonio, Texas:—The most recent reports have it that there are nineteen Federally-recognized National Guard air units. Each National Guard squadron is supposed to be provided with eight observation planes. In the general organization scheme they have what is known as Division Aviation, consisting of one Observation squadron and one Photo section for each of the eighteen Infantry divisions.

Norman Rowe, Milton, New Hampshire:—Many thanks for the clipping on Mata Hari and her execution. I found it

very interesting. The Curtiss P-36 uses the 1,100-h.p. Twin-Wasp engine. The Curtiss P-37 is being powered with the 1,000-h.p. liquid-cooled Allison motor. No performance figures have been given out on this ship. The details of Tony Fokker's latest plane will be found in this month's Modern Planes Album. It is known as the D-23.

Noel M. Aldridge, South Africa:—Safety slots are used to prevent stalling and are usually placed in the leading edges of the wings. Landing flaps act as air brakes and slow up the landings—or assist in take-offs by increasing the lift of a part of the wing.

Walter Gasko, St. Louis:—Anthony H. G. Fokker can be reached at his works in Amsterdam, Holland. The fastest plane of any type in the world is the Italian Macchi-Castoldi racer which has done 440 m.p.h.

John Silletto, Hollywood, Calif.:—The Ford tri-motor monoplane which used three 420-h.p. Wasps back in the 1932 era had a top speed of 138 m.p.h., cruised at 113, landed at 59, had a ceiling of

16,300 feet, and flew a normal radius of 580 miles.

Joseph Rawlinson, Salford, England:—I must disagree with you. Most gas masks in use over here will give protection against illuminating gas or coal gas. Perhaps those being distributed over there are not the same—but they should be because there is much more danger from illuminating gas in a bombing raid than there is from poison gas. In fact, as far as I can find out no gas bombs have actually been dropped anywhere in any war. Gas of the war poison variety must be discharged from cylinders and under the most suitable wind conditions. It cannot be discharged from bombs that explode because the explosion either burns it or dissipates it completely. Tell this to your Air Raid Precautions official in dear old Salford. In conclusion, thanks for the kind words on our Kerry Keen stories.

Sam Walker, Chicago:—You are puzzled by all the newspaper reports on the estimated strength of the German Air Force. I do not wonder at it, because nearly every report is different. But again I must remind you that none of these reports include any actual details on the planes in question. They do
(Continued on page 71)

The Airmail Pals

THE RECENT war alarm over on the other side of the big pond really threw quite a scare into our British cousins. As you probably know, they were outfitted with gas masks, and instruction as to how to defend themselves in case of air attack. And J. Douglas, of Glasgow, Scotland, one of our Palsters, really had a big enough share of the scare to last him for a long time to come.

Doug tells us that he was kept busy for several weeks digging trenches in his back yard, instructing the citizens in the use of gas masks, and the like.

"R.H.P.D., you'll never know what a mad time we had of it," he says. "I had intended to write for a Pal, but

the turmoil in my country simply kept everything out of my hands except war materials!"

' Well, fellows, somehow Doug *did* get time to write, and we immediately teamed him up with Rolf Slade, a worthy ink-slinger from Columbus, Ohio.

Nickels come into the office for the Kitty in umpteen different forms, but here's a chap who's really got a swell idea: Ed Brinton, of Philly, cut a piece of balsa just large enough to fit over his jitney, covered it with tissue, and then glued the whole thingamagig to the bottom of his letter—pretty good, helping the balsa industry, huh? Incidentally, you might like to know that the R.H.P.D.'s Kitty is getting very touchy these days. The fuzzy feline is now demanding *cream* instead of his usual saucer of skimmed cow juice. Yep, we believe he ought to be taught humility.

W. Jankowski, of 8639 Muskegon Ave., Chicago, has been quite ill for some time, and he'd like *all* of his pen pals to get in touch with him.

"Don't any photographers write in?" asks Sid Davies, also of the Windy City. "I don't care how long it takes to find one, just so long as you do. Pleez, *PLEEZ!* get me a Pal that can talk the gibberish of the hypo hounds and the neg nursers."

Well, after going through flocks and flocks of letters, we finally hooked Sid up with Roger Perrault, of Lyndonville, Vt., who's another photo phriend—and is just the type Sid's been lookin' for!

If any of you American chaps are looking for a real airdrome hanger-arounder, P. Middleton, of 13 Townton Road, West Bredgford, Nottingham, England, would probably fill the bill to a "T". He's been expecting a letter from one of his A.P.'s for quite some time, and has concluded that said pal has dropped him. So see what you can do, fellows, to brighten him up.

That ends the news for this month, scribblers. And now, *Bunkey Doo*—as our New Zealand Pals say—until this time next month.

—THE RIGHT HONORABLE PAL DISTRIBUTOR

HOW TO GET AN AIRMAIL PAL

FIRST, write the best possible letter you know how. Use your best pen-and-ink handwriting or a typewriter. In your letter, introduce yourself fully—for this is the letter we'll forward to the pal we'll pick out for you. Tell your age, your interests in aviation, your other hobbies, and any additional items that might interest a new friend.

Then on a separate sheet tell the R.H.P.D. what kind of an Airmail Pal you want. Send your letters to Airmail Pals, FLYING ACES, 67 West 44th St., New York, N. Y. Be sure to enclose a stamped, self-addressed return envelope, *plus* five cents in stamps or coin for each pal requested (our fee for the R.H.P.D.'s "Kitty"). We'll try to supply you with a pal in line with your specifications, although we cannot guarantee to fill the bill exactly every time.

Your new pal's letter will be sent to you, and yours to him—after which you will correspond direct.

Do not ask for "lists" of pals. We cannot supply them.

REGARDING FOREIGN PEN PALS

PLEASE NOTE that FLYING ACES' foreign circulation is only in English-speaking countries (specifically, Great Britain, Australia, New Zealand, and Canada). Therefore we cannot undertake to supply you with pen pals in Germany, France, China, etc.

If you are an American resident and want an overseas pen pal, *do not write a pen pal letter*. Instead, send us a short note telling in a general way what kind of a chap you are and what kind of a pal you seek. Enclose a stamped, self-addressed return envelope and five cents for each pal called for. A foreign writer's letter will be sent to you, then you may correspond with him direct.

If you live outside of the United States and want an American pen pal, write a complete letter as described in the first paragraph of this box, and send it *without* the return envelope but *with* an International Reply Coupon worth five cents. Get the coupon from your local postoffice. Your letter will be forwarded to an American correspondent, after which you need only wait for his reply.



WISECRACK-UPS



Taxi in on this runway and pick up a plane load of laughs! In this department, we present a collection of jokes, cartoons, and humorous verse. For all original contributions which we can use here, FLYING ACES will pay \$1. Contributions cannot be returned. Address all letters to WISECRACK-UPS.



Walker
 "Fessenden, you'll have to bail out. I simply CAN'T work with anyone looking over my shoulder."

THE PUNNING PINKHAM

Heinie prisoner (being questioned): Himmel! Mit mein staffel t'ings gedt verse yedt. Nine outd of ten of der flyers dey gedt shodt down!

Phineas: You mean life is justa toll of Jerries. Haw-w-w-w!

ILLITERATE MODEL

Junior (crying): Wah-h-h! I've gone an' lost my gas job. It flew outa sight.

Mother: There, there, son! You can put an ad in the paper for it.

Junior: B-b-but that wouldn't do any good. It can't read!

SAFETY FIRST
 Sign On Flying Flea—
 Grounded Until After
 The Duck Hunting
 Season

KNOWS HIS SON

"Pop," said Junior enthusiastically, "I have some balsa wood, some wheels, a propeller, tissue paper, and paint. Can you guess what I'm going to make?"

"A mess," came his father's prompt answer.

TIGHT QUARTERS

Greaseball: Yes, I said I saw *The Dawn Patrol* at the Bijou last night.

Screwball: But how did they ever get in there?

PROOF OF IT

With a terrific *ker-wham*, the D. H. observation bus bearing those two stalwart Irishmen, O'Toole and O'Sullivan, crashed into No Man's Land.

Presently, the weak voice of O'Toole was heard from within the wreckage:

"I say, there, O'Sullivan! An' how ar' ya?"

"Oi-m alive," came back O'Sullivan.

"Sure, an' ye've always been sich a liar, I don't believe ya," declared O'Toole.

"Begorra! Thin Oi'm dead!" wailed O'Sullivan. For no damned O'Toole iver dared call an O'Sullivan a liar whin he was livin'!"

IMPERTINENT

Stewardess (indicating safety belt): Now just strap yourself in, madame.

Heavy lady passenger (incensed): I'll ask you not to be fresh! I'm already wearing a girdle!

UNNECESSARY EXPENSE

Pilot (to lady student): And now we'll taxi down the field.

Lady stude: Don't be so extravagant. I have my own car here.



"You big brute! Frightening those poor little chimney swallows!"

SHOCKING EMERGENCY

"Calling all Flying Fleas
 Calling all Flying Fleas All
 Flying Fleas must be provided with
 pants, since a flock of ladybugs have
 been reported in the vicinity."

After seeing an arrow insignia on the fuselage of a war plane, Dumb Dora decided it was put their to show the pilot which way the plane would fly.



MEL SODERLUND

"Well, you WOULD tell Junior about that Mayo Composite business!"

Modern Planes Album

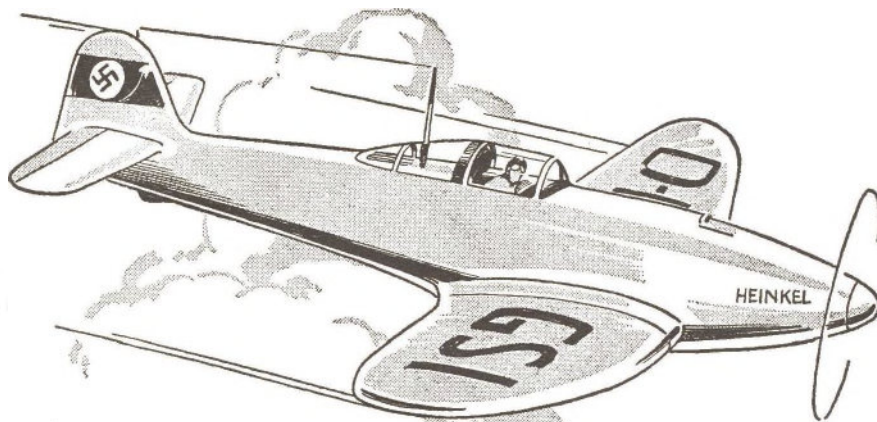

HEINKEL HE.112 FIGHTER

HEINKEL HE.112 FIGHTER

WE have been hearing a lot, both pro and con, concerning the strength of the new German air service. And the emphasis, thus far, has been on the great Messerschmitt M-109 fighter, which has been turned out in special souped-up form and also as a normal service ship, the latter differing decidedly from the former in performance.

But now let us talk about another of Hitler's military jobs—the HE.112

developed during the last couple of years by the Ernst Heinkel Flugzeugwerke of Oranienberg, which is near Berlin. This is a single-seat fighter powered with the 660-h.p. Junkers Jumo 210, a twelve-cylinder Diesel power plant driving a two-bladed, constant-speed prop. This engine is a water-cooled inverted-Vee type. Fuel tanks are carried in the center portion of the ship's wing.

The HE.112 looks much like the standard low-wing fighters manufac-

tured in Great Britain. Its wings are cantilever, and the wingroots are swept up at their junctions with the fuselage. The outer portions of the wings are elliptical in plan form, much like those of the Supermarine Spitfire, and they taper in thickness. The whole of the trailing edge is hinged in such fashion that the outer portions act as ailerons while the inner portions are employed as landing flaps.

The plane is all-metal in structure. The undercarriage retracts upward and outward into the wings. And the pilot's cockpit is fitted with a transparent sliding hatch.

Two fixed machine guns are fitted into the sides of the fuselage to fire through the airscrew, and two automatic guns of unknown manufacture are set in the wings outside the prop's arc. Racks for six 22-lb. bombs are ensconced beneath the wings. A two-way radio set is standard equipment.

Top speed is 316 m.p.h.—quite an increase over earlier estimates. And she cruises at 298 and climbs to 3,280 ft. in 1.2 minutes. A range of 2,100 miles at normal cruising speed is boasted.

FOKKER D-23 FIGHTER

TONY FOKKER again startled the Paris Air Show crowd, this time with an eye-opener in the form of the new and unusually designed D-23, a single-seat twin-engined fighter powered with two Walter Sagitta engines.

The motors used are twelve-cylinder, inverted-Vee air-cooled jobs manufactured by the famous Walter Motor Car Company of Prague, Czechoslovakia. They are rated at 600-h.p. each, thus this new Fokker fighter has 1,200 horses under its hood.

It remains, however, that the D-23 is a derivation of the earlier G.1 which featured two tractor radials set into the leading edge of the wings. In that plane, the tail booms proved to be too much of a "blind spot" for the tail gunner.

In this new fighter, the pilot sits high behind the front engine and is protected from behind by the rear engine. And owing to the happy arrangement of the tricycle undercarriage, allowing a longer nose, his forward view is particularly good. In addition, the pilot is further protected by armor plates set in front of his

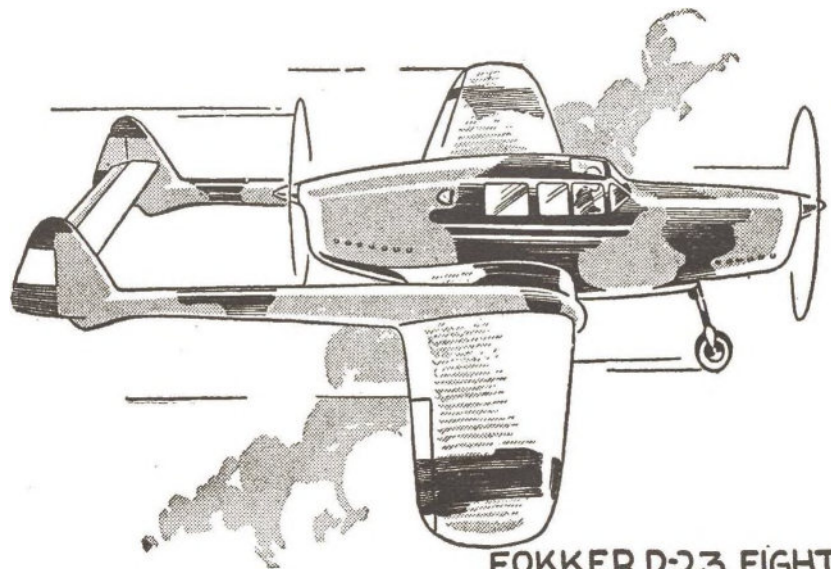

FOKKER D-23 FIGHTER

seat and also alongside the cockpit. Thus we see that after twenty years, designers are again considering the physical risks of the pilot. The last plane that used armor was the 1918 Sopwith Salamander—the original attack plane.

Four guns are fitted in the D-23, two in the fuselage and two in the wing. The fuselage guns are Brown-

ing F-N's of 7.9 mm. caliber. The wing guns are of the same manufacture but are 13.2 mm. weapons—in all probability the new heavier Browning gun we have been hearing about. We understand that a special explosive bullet is used in these wing guns.

The expected speed of the D-23 is something like 330 m.p.h.

NEWEST OF FIGHTERS—ORTHODOX AND UNORTHODOX

With the world's great air powers striving to outdo each other in building huge sky-fighting fleets, the designers are having a field day and startling models are now competing with the conventional jobs.

Herewith, we present two of the unusual ships side by side with two flyers of more standard type.

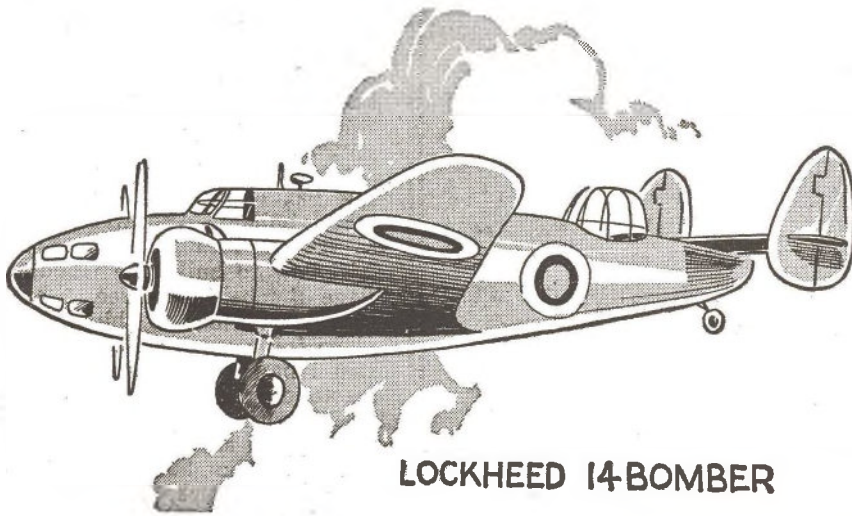

LOCKHEED 14-BOMBER

LOCKHEED 14 BOMBER

AMERICANS should be interested in this late addition to the British R. A. F., since it is an American ship. It is interesting, too, that the British experts, after careful consideration of our types, should select a plane which to the ordinary eye appears to be little more than a revamped high-speed transport.

The first of these Lockheed 14's

has been flight tested. And according to unofficial information—of which there is plenty—it is one of the fastest bombers in the world. Britain ordered 200 of them, to fill emergency needs, and meanwhile it's said that both flight and maintenance crews will have to be specially trained to handle them.

For one thing, 750-h.p. P. & W. "Hornet" engines are employed,

which will be new propositions for the British mechanics. Also new tools will have to be adopted because of the difference in thread-nut measurements in British and American practice. The pilots, moreover, will have to become accustomed to the peculiar characteristics of the Lockheed, which uses the famous Fowler flaps, adding something like 27% to the wing area in flight operation.

Armament details are not available, but it is obvious that at least one and possibly two guns will be placed in the nose turret. Two more will be set in the rear turret and possibly another will fire out of a tail tunnel at targets below and behind. The obsolete dome turret (see sketch) will no doubt be replaced with the new Fraser-Nash armored turret.

They say this job will be used as a reconnaissance-bomber, possibly to augment the Avro Anson patrol in East Coast defense work.

But whatever duties the Lockheed 14 will be required to perform, it will be quite interesting to see how one of our American products stacks up against British military ships.

PAYEN FLECHAIR FIGHTER

THE YEAR 1939 has opened with a startling display of unusual fighting planes. And foreign manufacturers will not have all the edge in the matter of strange craft, either. For we learn on good authority that our Army Air Corps is bidding for a single-seat fighter of 450-m.p.h. top speed, to carry an air cannon, and if possible be a pusher. Maybe Crash Carringer's *Hale Hellion* will at last come into its own.

But the most unusual craft to reach mock-up stage seems to be the new French Payen Fléchair. That name means "arrow"—and this job certainly looks like one!

Of tantom sesquiplane type, it must be presumed that this ship's long feathering tail-plane constitutes part of the main lifting surface. Incidentally, it is set slightly below the line of the main wings. Certainly the most striking piece of proposed fighting equipment we have seen in ages, this plane is to be powered by two 100-h.p. Salmson engines set in tandem and geared to drive two concentric airscrews. Yet even with only this 200-h.p. available, the designer claims he will get 285 m.p.h. out of it.

Further reports say the Fléchair

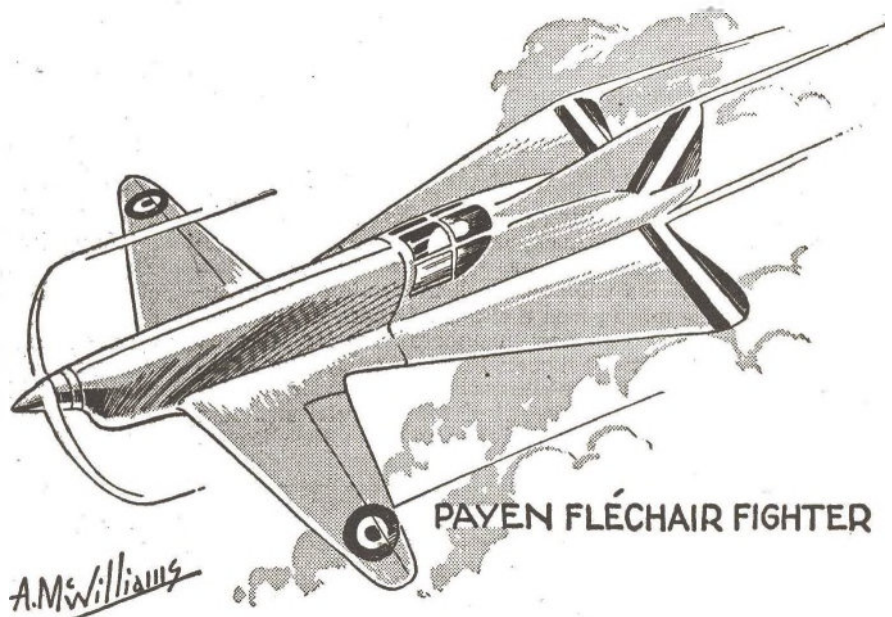

PAYEN FLÉCHAIR FIGHTER

will have but a single landing wheel under the fuselage and that auxiliary skids for maintaining balance on take-offs and landings are to be fitted to the wing-tips.

Owing to the strange layout, the designer has had a problem placing the pilot where he will obtain the best arc of vision both in action and landing. For this reason, the cockpit has been located well aft. As for arma-

ment, two automatic air cannon are to be set in the leading edges of the main wing.

Even though the Fléchair has been designed on a totally new principle, it might prove to be an impetus to bring military aircraft back to the low horse-power field. And then, if it shows any promise, we may see the seemingly endless high h.p. experimentations slowing down a bit.

Flying Aces Club News

By Clint Randall

National Adjutant
Flying Aces Club

AND NOW all you lads of the FLYING ACES CLUB, the March winds are once again starting to blow. Yep, summer's just around the second-next corner, and all of you buzzards will soon have better weather for your weekly trek down to the nearest airport.

All of which reminds old Clint of the days when he, too, sat in the bucket seat of a sky buggy behind a few hundred horses that carried him through the ozone over many a square mile of the globe.

But let's take-off pronto into the news that you've been waitin' to hear—

THE FIRST letter in the batch is from Lewis Barton, of Clifton, Texas. Although this joy-stick cowboy is a little older than most of you fellows, he's just up to his neck in the old game. He's been interested ever since the Big Fuss, and he says: "I got a permanent crick in my neck from looking for Jerry planes when I was over in France as an engineer."

Well, buzzards, you might be interested to know that Lewis is an F.A. Escadrillian, and is very close to receiving his first award. Religiously, he has shipped us his monthly reports—at times, even sending two a month—and he's about to be repaid for his splendid work in making the Escadrille bigger and better than ever!

And now, do you remember our old pal Tony Mendolia? Well, Tony's about to leave his home drome in search of happier hunting grounds. Yep, he's signed up with the Navy and is now a gob—almost! Almost, because he's waiting to get a call from the Navy Department any day—in fact, any hour! But he promises to try to work his way into the Naval Air Force and thus keep the good old F.A.C. banner spanking in the breeze.

So let's wish this fellow Clubster luck, boys, in his ambish to reach his ceiling—the Air Force!

Charley Metzler, of Lockport, N. Y.—he needs no introduction to you fellows—has again broken the ice, too. Yep, because of his valuable work in signing new members, he's once more given a chunk of space in the Club News. Here are the new members Charley signed: Harvey Schultz, Otis Willoner, Phyllis Conley, Dot Lockwood, Jean Pils, Marian Weaner, Doris Metzler, Gladys Weaner, and Tom Mulvey. All of the new girl members just named have banded together to form the FLYING

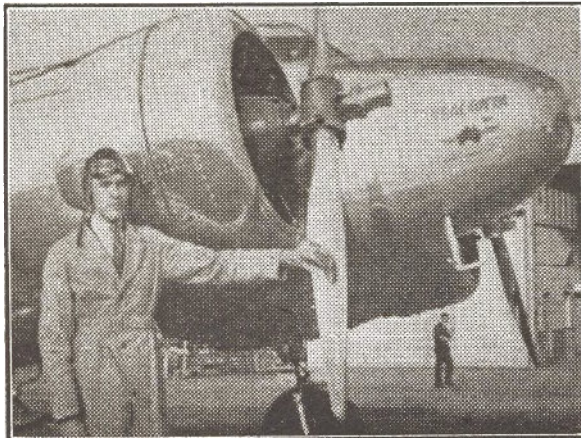

Ready to take off? Nope, Bob Day, of Ansett Airways, Ltd., Melbourne, Australia, is just posin' to have his "pitcher" took. He says he can't fly that Lockheed "Electra" yet. But there'll come a day, as Joe Penner says. And anyhow, Bob has his helmet and goggles—so bring on a training plane!

Gosh, doesn't it feel great to have spring headin' this way again? Sure makes a guy perk up a notch or two, don't you think? Why Clint is even sitting up straighter in his "office cockpit!" Yes, he's all set for a hangar chat with all you aviation-boosting fans. So let's soar into the meat of the news and see what all of you fellows have been doing—

ACES Nurses Division. Doris Metzler was the organizer.

Bob Day, whose photo appears at the bottom of this page, is a very up and coming Australian who has both feet in the aviation game. He says:

"I not only work for an air-line but I am also an old time model builder. And was I glad to see in 'Trail Blazers of the Air' how to build the Handley-Page Bomber! You see, I have been intending to build that plane for a long while, and now that I have the plans there'll be no stopping me!"

Well, that's Determination with a capital "D"! And from looking at Bob's photo, we'd say that chin of his really shows determination—and that he'll probably go a long ways in the aero line. Good luck, Bob!

To R. M., of Coffey Ville, and others who wonder why they haven't received an answer to their letters: If you read the "Join the FLYING ACES Club" page again, fellows, you'll see that it says you *must* send a self-addressed, stamped envelope along with your letters to Clint. Every month we receive a slew of letters without return postage, and we're sorry they can't be answered. You see, the staff here at G.H.Q. has to run the organization on a strictly military air service basis. And we're sure that's the way you want us to run it. And now, let's all read the "Join the F.A.C." page once more—so we'll be better Clubsters. Okay?

And now that's off our chest, here's the rest of the news:

BOB WELLS, of Oakland, Calif., has a very sad story to tell. Bob says:

"The last model I built was a Nieuport 28. For one of its flights—which proved to be the *last*—I took it to 'Frisco and launched it from the Chronicle Building. It did one loop and then power glided for about 600 feet. The model then went into a stall and did a 9-G'er for 36 floors directly to the street! From where I was, I didn't see the ship hit. But if it wasn't wrecked then, a passing street car ran over it and finished the job."

Tough luck, Bob. But you really should feel proud. Yessiree, we'll bet our last Dzus Fastener that your model is the first one that ever did a *real* terminal velocity dive! And, incidentally, how many of you fans know what a Dzus Fastener is?

Lawrence Robinson, of Oak Grove, Mo., and Oral Stowell, of Kingman, Ariz.—along with a host of other fellows—have registered a complaint. Yep, they don't like F. A.—because it's published only once a month!

Hey, do you wanta *kill* the poor editor with work?

Walt Gunning, Jr., of Remus Point, N. Y. has just finished what he considers to be the best model of his career as a builder. It's a Boeing F4B-4, complete with ignition wires, spark plugs, engine cooling-fins, glass covered instruments, shock absorbers, and a 355-piece replica motor!

We'd say Walt's got something there! Have any of you other fellows built a model that's *more* detailed?

Ever hear of Ruth Nichols, Cecile "Teddy" Kenyon, Betty Gillies, or Margo Bain Tanner? Sure you have! And you know that they rank among the best woman pilots in the country. Well, fellows, you'll hear something new about them very

shortly. And here, fellows, is why:

When 20th Century-Fox Studios decided to make their movie called *Tail Spin*, they got in touch with these gal pilots and gave 'em nice contracts to come to Hollywood and act as experts on the film. After the picture has been "shot", the pilots will make an air tour of the key cities of the country—'Frisco, Seattle, Salt Lake City, Denver, Chi., St. Louis, Detroit, Cleveland, Pittsburgh, Kansas City, Oklahoma City, Dallas, New Orleans, Memphis, Atlanta, Philly, Boston, Newark, and New York. Don't fail to see 'em if your home tarmac is on that list.

Bob Achterberg, of 718 Church St., St. Joseph, Mich., has plans for organizing a state-wide unit of the F.A.C. His program sounds very interesting. And all of you Wolverine Clubsters should drop Bob a line.

And now, how'd you like to have an uncle like Bill Darby's? Bill, who lives in Big Spring, Texas, has an Unk who owns two airplanes—and he taught Bill to fly in one of 'em. Yes, sir, we'd call that a gift right from Valhalla, wouldn't you?

And remember the old "Jennies?" Well, R. C. Dempsey, of Colby, Wis., tells us that he once paid \$1.00 per minute for flying time in one of 'em. And what's more, his trip was only as a passenger!

R. Dunne, C. O. of our Dublin, Ireland, F. A. Squadron, is really interested in the Club—and what we mean, *really* interested! He's just written us that he wants two dozen pairs of F. A. wing emblems for the members of his outfit. Yep, when those Irish do something, they do it in squadron style. And that's a tip to the rest of you.

Ever hear of an aerial bomb for advertising purposes? Well, Bernard Revering, of Perham, Minn., is working on one. He intends to shoot the "bomb" from a shot-gun. And, if the darn thing works, it'll open with a FLYING ACES banner streaming from a chute.

But Bernard hasn't got up enough nerve to try it yet—he's afraid he'll spoil his new shot-gun! Sad situation, huh?

JOHNNY BUCHANAN, of Dorchester, Mass., was just in the office here at G.H.Q. It seems that he's an expert metal mechanic and riveter—out of a job! Johnny's heading out to Grumman and Seversky to see if there's anything doing. Let's all hope that he'll be able to break the ice.

Bill Mickelson, of Racine, Wis., is working hard to put his home town on the aviation map in bigger style than ever. He and a group of other fellows are organizing a couple of NAA chapters for rubber and gas modelers

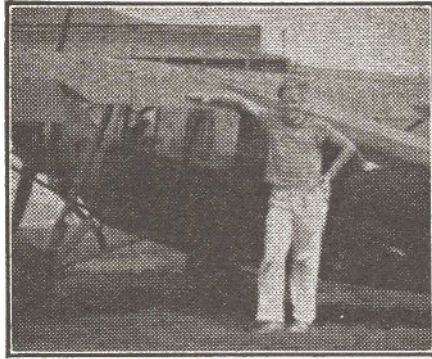

This smiling lad snapped in the act of giving a Rearwin "Sportster" a loving pat is Karl Frick, of Maywood, Ill. Karl says, "I want to get to the top in your Club—and I'm surely going to do it!" That's what we call the real spirit. And by the way, Karl, does Oak Park High still beat the tail skids off Maywood in football? Ye Ed of F.A. used to go to O.P., you know—and he tells Clint his Alma Mammy used to do big things with the pigskin in his day.

in that good old Badger community.

Personal to Gene Martin, of Waterloo, Iowa: No, Gene, you certainly don't have to join our F. A. Club every month, or every year. You join—and you're in! We print the month on the applications just so's we can keep our records straight when the new members come in. One application gives you a life-time membership in the Club.

Roy Cameroi, of 1021 Chestnut St., Hamilton, Ohio, would like all nearby fellows interested in starting an F.A.C. Flight to get in touch with him. Roy's in earnest, so give him a break, will ya, fellows?

Ever hear of the N.P.J.A.? Well, it means National Parachute Jumpers' Association. And R. W. Rongenecker, of Peru, Ind., one of our Clubsters, is a full-fledged member. He says: "My experience as a parachute jumper has

been uneventful, and there's not much to say about myself." Gosh! Ronny talks about it just like he was ordering a bowl of clam chowder!

Did you ever look at the window of a model store with envy in your heart? Well, Bill Bailey, of Ardmore, Okla., is one fellow who doesn't. Bill's father owns a hardware store in Ardmore and handles Megow models. Guess Bill's Pop has to keep this fellow Clubster of ours away from the model shelf instead of away from the jam jar!

And now, fellows, for the next several lines we'll go through the rest of the mail for choice items: Jim Simpson, of 404 Shepherd St., Chevy Chase, Md., would like all FLYING ACES Clubsters in his vicinity to get in touch with him . . . George Hamilton, P. O. Box 182, Camden, N. J., will be in Plattsburg, N. Y., in the latter part of August during the Army maneuvers. He would like all you fellows in that district to contact him without delay.

Joe Farino, of Newark, N. J., a 13-year-old lad, is interested in the "lighter things" of aviation. He's scouting around for plans of a man-carrying glider . . . From Halton, England, Bill Frobisher writes in and suggests an all British "With the Model Builders" page for one of our issues. We think it would be a swell idea, and would like all of you English chaps to shoot us a photo of the best model you have on hand.

Those letters are piling up in front of Clint again, fellows. Another stack was just brought in by the mail truck, and if they're all to be answered 'fore it's time to dash off another Club News page, Clint had better call it a day.

So your N.A. will be seeing ya again next month with more chatter about all of you.



Talk about a change! Just look at the metamorphosis—or whatever it is they call it—that's come over our popular Honorary Member, Jackie Cooper, in four short years. On the left we see him as he appeared back in our March 1935 Club News at the time he was making the movie "Treasure Island" with actor-pilot Wallace Beery. And on the right we show him in his very latest "still" as he takes time off from the filming of Monogram's "Gangster Boy" to put the finishing touches on a flying-scale model. Fact is, Jackie was in such a hurry to get back to the work-bench here that he didn't even pause to slip out of that boiled shirt he's wearing.



JOIN THE FLYING ACES CLUB

Honorary Members

President and Mrs. Franklin D. Roosevelt
 Vice Pres. John Nance Garner

Casey Jones	Rear-Admiral Byrd
Wallace Beery	Capt. Eddie Rickenbacker
Al Williams	Colonel W. A. Bishop
Col. Searonl	Major G. A. Vaughn, Jr.
Major von Schleich	Willy Coppens
Lieut.-Col. Pinsard	General Balbo
G. M. Bellanca	Walter H. Beech
Capt. B. Sergievsky	Frankie Thomas
John K. Northrop	Dwane L. Wallace
Colonel Roscoe Turner	Josef Veltjens
Charles W. A. Scott	Maj. A. P. de Seversky
Richard C. DuPont	Donald W. Douglas
Maj. A. W. Stevens	Major C. C. Moseley
Capt. O. A. Anderson	Clarence D. Chamberlin
Major Fred Lord	Mrs. Charles S. Bayless
	Lieut.-Col. Theodore Roosevelt

Official Charters

F.A.C. Flights and Squadrons are recognized at GHQ only after they have received their official charters. These illustrated documents, printed on fine paper and portraying various features in the field of aviation, are excellent for framing and display. Their inspirational text is in keeping with the high ideals and aims of our Club. Each charter application must include a full list of proposed group members and their addresses. Each of these members must hold his regular F.A.C. card, obtained by clipping and sending in the membership coupon printed on this page. If applications are approved, Flight Charters are issued for 25c, and Squadron Charters for 50c. Send the correct fee with your application. It will be returned if the Charter is not granted.

WIN YOUR WINGS

Save This Whole Coupon for
CADET OR PILOT
 insignia of the F.A.C.



Gold finish Actual size

All members with Official Membership Cards are eligible for Cadet Wings. This coupon, with two others and 10c, entitles members to Cadet Wings. Do not send this coupon alone. Save it until you have three. Then send them in all together with a self-addressed envelope and 10c to cover cost of wrapping and mailing.



Silver finish Actual size

All enrolled members who have won their Cadet Wings are eligible for Pilot's Wings. This coupon, with four others and 10c, entitles Cadets to Pilot's Wings. Do not send this coupon alone. Save it until you have five. Then send them all together with a self-addressed envelope and 10c to cover cost of mailing.

Send the Whole Coupon

regardless of which kind of wings you wish. Separate sets of coupons are needed for each insignia. Canadians send 15c, or three International Reply Coupons. Overseas readers send 1/-, or five Reply Coupons secured at the Post Office. Only one pair of either kind of wings to a member. If yours are lost, send 25c for new ones (2/- overseas). [49]

Do Your Full Share to Advance Aviation

To advance the cause of aviation, over 50,000 men and women, boys and girls, have banded together to form the **FLYING ACES CLUB**.

It is the easiest club in the world to join. Just clip the membership coupon, fill out, and mail it to GHQ with a stamped, self-addressed envelope. Your official card will then be forwarded to you. After joining, you can quickly win promotion and the right to wear the various insignia of the Club.

In the **FLYING ACES CLUB** there are two kinds of local organizations, known respectively as Squadrons and Flights. A Squadron must have eighteen members, including its leader. A Flight must have a total of six. You can start either of these groups in your own community by enrolling your friends in the Club, then applying for an official charter as detailed in the column at the left. *Each member must hold an F.A.C. card.*

Meetings and activities are conducted among the squadrons and flights according to the wishes of the members. GHQ has established no rulings in this respect, nor are there any dues or red tape whatsoever. The entire idea of the Club is a common meeting ground in an international organization for the lovers of aviation in its various phases. Many local Squadrons and Flights hold regular contests and public events. Many hold weekly meetings for model building, and instruction, and even regular flight training.

Awards and the Aces Escadrille

After the membership card, and Cadet and Pilot's wings, comes the Ace's Star. This is awarded for enrolling five new members, using, of course, a separate coupon for each. As an Ace, you are then eligible for membership in the **FLYING ACES ESCADRILLE**. Then you may win truly handsome awards. Among these are the Distinguished Service Medal and the Medal of Honor, two of the finest decorations that have ever been designed.

Any member who has reached the rank of Ace is eligible for membership in the **FLYING ACES ESCADRILLE**, an advanced organization which replaces the old G-2 unit and opens the way for participation in a definite program contributing to the forward movement of aviation.

To enroll, an Ace must apply direct to Escadrille Headquarters, giving his name, age, address, rank, and highest award already won in the Club, and enclosing a stamped, addressed return envelope. If he is approved for membership his instructions will be forwarded. Membership in the Escadrille is limited to American and Canadian members only, at present.

Special Service!

This Aviator's Positive Identification Bracelet



Registration and Bracelet Only 25c!

A valuable identification service for F.A.C. members is now offered with our World War type aviator's bracelet. Every one now issued will bear a serial number—which is the key to your confidential identification record on file at GHQ. In emergencies where prompt identification is needed, this number may be sent to GHQ, and identification facts will then be furnished. When ordering, send your name, address, occupation and full physical description—age, height, weight, color of eyes, hair and complexion, etc., together with name and address of nearest kin. Overseas readers may receive bracelets and be registered for 2/- in coins or Int. Money Order of same amount.

Keepers of the Log

In order to keep in touch with GHQ, every squadron should appoint a member with a facility for writing as Keeper of the Log. It shall be the duty of the Keeper of the Log to send in regular reports of interesting doings of his squadron. His is an important job, because it is only by means of interesting squadron reports that life can be given to the **Flying Aces Club News**.

Photographs, too, are an important consideration for the Keeper of the Log. Either the Keeper himself, or any other member with a camera, should keep a photographic record of the squadron's activities, for reference purposes, to show prospective new members, and to allow a selection of pictures to be sent to GHQ for reproduction in our monthly **Club News** pages.

The cost of film, prints, etc., would be a legitimate charge against the squadron's own treasury or could be covered by members' contributions. A number of flights and squadrons, incidentally, send us prints which have been taken, and completely developed and printed by foto-fan members of the outfit.

Correspondence

In all correspondence with GHQ where a reply is desired, enclose a stamped, self-addressed return envelope with your letter. GHQ receives thousands of letters weekly, and cannot undertake to answer those who do not heed this rule.

Official Supplies

Due to popular request, we have ordered a new supply of F.A.C. stationery and official F.A.C. (paper) pennants. The stationery is of high quality with the **Flying Aces Club** letterhead attractively hand-lettered, and the price is amazingly low—100 sheets, postpaid for 25c. The attractive pennants (with glue on the back) sell at 6 for 10c or 20 for 25c.

We also have a new supply of swell embroidered wing insignia for cap or sweater made up in colorful blue and gold, they're available at 25c each.

(Overseas prices: Stationery, 100 sheets for 2/-; pennants, 20 for 2/-; wing insignia, 1/6.

April Membership Application

I, the undersigned, hereby make application for membership in the **Flying Aces Club**. I agree to live up to its rules and regulations; to foster the growth and development of aviation; and cooperate with all other members in the work of spreading aviation information, building up confidence in flying for national defence and transportation. I will aim to build up the Club and its membership, and do my best to win the honors that the **Flying Aces Club** offers.

My name is
 Age [49]
 Street
 City State

Do you build airplane models?.....
 Mail this application, enclosing a self-addressed, stamped envelope. Canadian and overseas readers send the application, self-addressed envelope, and an International Reply Coupon worth 5c, secured at the Post Office.

FLYING ACES CLUB, 67 W. 44th St., New York

With the Model Builders



Left: CR-R-R-ASH! WHAM! This Jerry Albatros D-4 has hit in an honest-to-gosh Chinese three pointer in No Man's Land! Chuck Garrett, of Hammond, Ind., built the ship and laid out this striking model scene—which looks real enough to "get by" on the "Snapshots of the War" page. The gray terrain and shell-stripped trees especially appear to be the McCoy.



The glad hand of modelers is extended here by two of our English readers, of Guilford, Surrey. Ray Corps and Dennis Allen, the chaps in the photo, are showing the warm friendship that modelers the world over receive from other fellows in the game. Anyhow, that's the old spirit we like to see. There can't be too much of it.

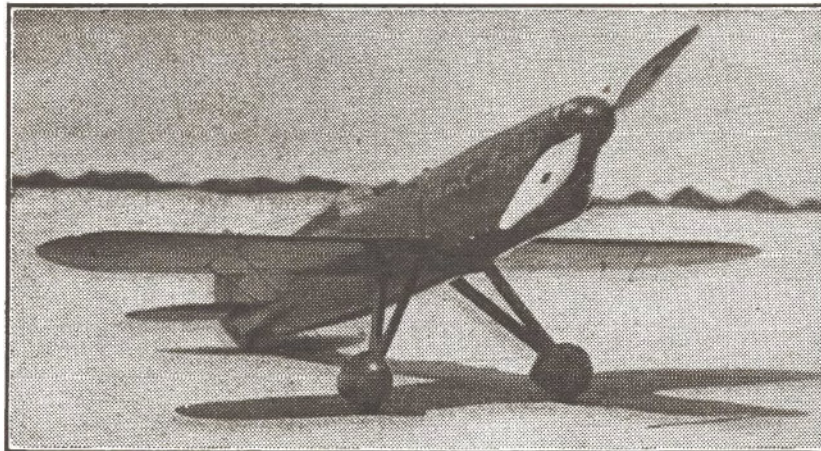

This Brown Special "Miss Los Angeles" is just about the sleekest model racer we've ever seen. Yes, the builder, Don Barth, of South Bend, Ind., made his 18" job as an exact replica of the famous ship. We honor it as our "Model of the Month." For here Don has given us everything down the line from beautiful workmanship to swell photography.

Below: Nope, this isn't the Paris Aero Show. Those copies of F.A., showing faintly in the background, give it away. But these striking ships—some of George Lufts' prized models—come pretty close to looking like a real-life exhibit. George hails from Manchester, N. H. And he's a corking modeler as well as an ace-high photographer, we'd say.

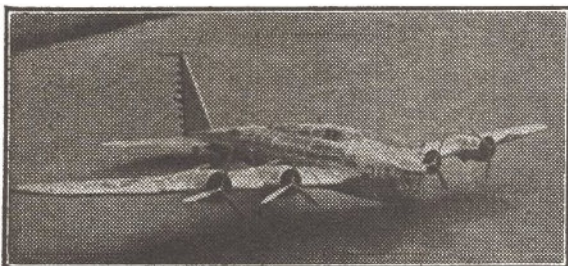

Above: Bill Lynch, of Ozone Park, L. I., is the artisan who turned out this miniature of the Boeing B-17. Covered with sheet aluminum and "riveted" with pins, this "Flying Fortress" took seven months to build—seven months of after-school time!

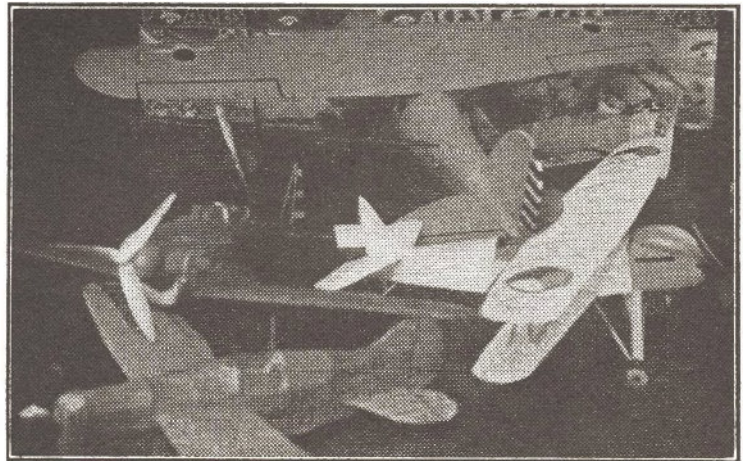

Right: Thirteen-year-old Doug Lewis, of 659 Lotus Ave., Oradell, N. J., tells us that this gas job, the "Red Zephyr," is only his SECOND gas model. Wow! From her detail and clean workmanship it looks like Doug has been in the game for years! Doug has put this sweet baby through 35 flights without one crackup! And he attributes his smooth landing success to the fact that he's equipped the ship's undercarriage with shock absorbers. And if you want the same sort of easy set-down, then why not "Fit Your Gas Job With Knee Action," as is explained a few pages ahead in this model section? Incidentally, if any of you fellows have a model "D" gas tank on hand, Doug would like to get in touch with you.

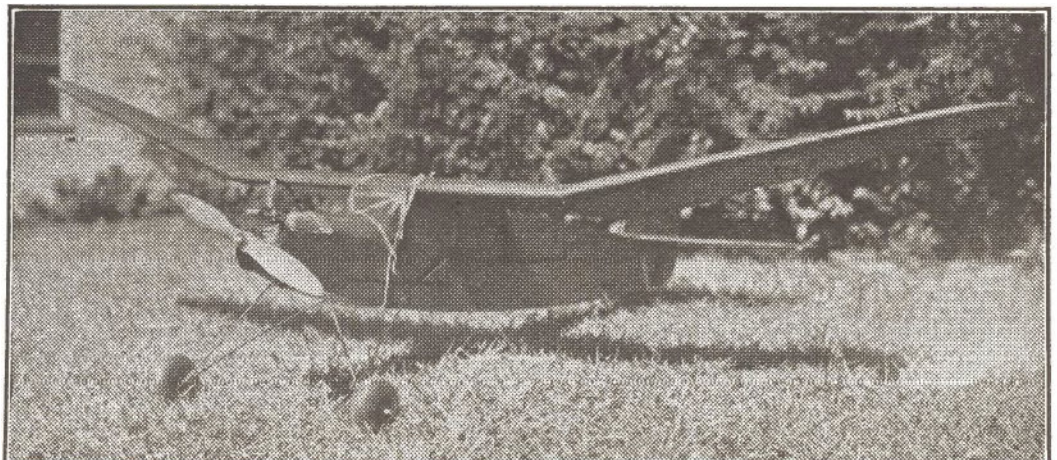

Flying-Scale Scoop—

The Curtiss XP-40!

* * *

By Jesse Davidson
and Harry Appel

A FAST-DASHING flying model of a new Army pursuit! That's the kind of job which we know goes over the biggest with all you modelers—and that's the kind of miniature skyster we have for you here in this Curtiss XP-40 pencil-streamlined winged hurricane!

Granted, this striking craft—we mean the *real* XP-40—is on the secret list. So we don't know the full inside details of how this cloud hurtler ticks. And we wouldn't be allowed to give you such *sub rosa* dope if we did.

But "hush-hush" policy to the contrary, you can still have a staunch and speedy rubber-powered replica of this fighter on *your* model tarmac. And in this article we give you full instructions on how to go about it.

First off, readers who are familiar with the Curtiss XP-37 will notice that the lines of the XP-40 bear a great similarity to the earlier craft. Upon closer study, however, new details are revealed. The pilot's compartment has been moved farther forward and is completely enclosed by the usual sliding hatch. What's more, a new and more powerful engine—namely, the Allison 12-cylinder liquid-cooled plant which develops something like 1,620 h.p.—is said to drive the XP-40 at a cruising speed of better than 350 m.p.h. And top speed? Well, rumor has it that the ultimate velocity is in the neighborhood of 400 m.p.h.!

Wow! No wonder they're hush-hushing her!

Machine guns within easy reach of the pilot are the latest Browning .50 caliber type. Another appetizing bit we'll pass on to you is the stirring gossip that recently reached the ears of Walter Winchell. This story has it that our Air Corps master-minders are somewhat worried that the XP-40 may fly so fast that it'll be darned hard for our flyers to aim 'er straight!

The XP-40 is the latest modification of the original Curtiss Hawk 75 low-winger which made the last of the old Hawk biplanes look like a wartime Jenny by comparison. The fuselage of the XP-40 has been effectively thinned out behind the cockpit, resulting in the attainment of increased speeds through streamlining. The wing is of all-metal structure, internally braced, and completely housing the retracting landing gear.

Ailerons, rudder, and flippers are of metal construc-

tion, fabric covered. The three-bladed Curtiss constant-speed prop is encased in a spinner cap, giving the ship's external appearance extremely clean lines. And it also gives the real-shipish streamlined looks.

THE MODEL'S FUSELAGE

THE HOLLOWED type of fuselage used in our model has been chosen because this is the best way to simulate the metal skin used on the actual ship. The fuselage, which is carved in halves, necessitates the use of stiff paper templates for its top and side views, as well as for the cross-sectional contours.

Fuselage blocks should be of the softer balsa variety and knot-free throughout. The first step is to cement both fuselage blocks together very lightly since they must later be separated. Trace the side views of the fuselage on both sides of the block and remove all the excess wood with a sharp knife. Use sandpaper to smooth the surface and then trace out the top view of the body.

Reverting to the fuselage plans for a moment, notice the section starting just aft of the sliding hatch, marked "C-C". At this portion the upper part of the fuselage is channeled. To get the proper dimensions and contours, make a stiff paper template of the portion to be channeled, trace the template in its proper position, and carefully carve out the channel. A fuselage cross-section template at "C-C" will provide the depth at the extreme width.

The next step is to carefully eliminate the wood portion of the fuselage which forms the cockpit housing. The section is identified on Plate 1 between "B-1" and "C". The slanted broken line at "C" indicates the angle at which the rear portion is cut.

Later—after the fuselage has been hollowed—this portion is completely covered with celluloid to form the cockpit enclosure.

The fuselage blocks are carefully pried apart with the aid of a long, thin bladed knife. Another inside template must be made and cut to shape by following the series of dotted lines which indicate the wall thickness throughout the fuselage design.

This template is then traced onto the inner side of each fuselage half. All of the wood inside of the new outline is to be removed. You'll find that the walls are about 1/16" thick all around the fuselage except the portions near the nose and the extreme tail. Use a sharp knife and work slowly and carefully. When nearing the bottom of the shells, use coarse sandpaper to smooth out the rough spots near the 1/16" wall

When our Air Corps gets "het up" over a sensational new military machine—then it's time for ol' F.A. to step in and give you model fans a corking copy of 'er. Well, fellows, Curtiss HAS turned out such a ship—the striking XP-40, rumored to be the fastest fighter in the world. And now here, in double-quick style, we have Jesse Davidson presenting you with a keen flying replica of this remarkable low-wing combat job. Go to it, modelers—

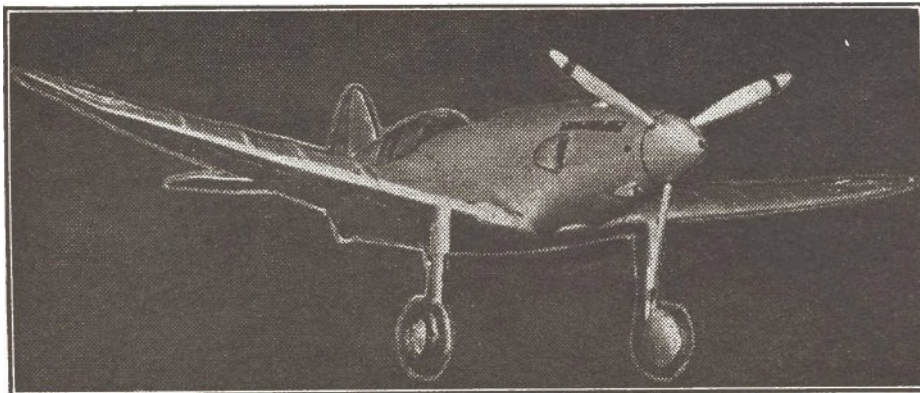

Left: This is how your peppy XP-40 will look coming in for a dead-stick landing. Yes, we know that's a scale-prop on her instead of the flying-prop. But when your own job is off the workbench you'll be ready to bet your last safety belt that this nifty ship will fly even with a display aircrew!

Right: Here she comes right at you—showing the fine lines that make her a blue-streak in the air. And don't mind her being a low-winger. She'll stack up with the best of 'em regardless. Construction is easy, too. Just flip this page and you'll find four fine plates showing you how to go about it.

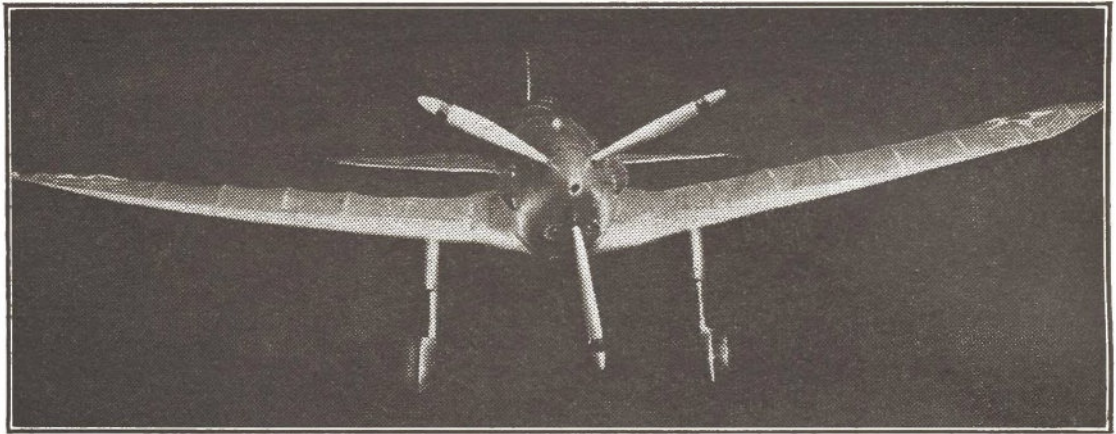

and then finish the sanding job with very fine paper.

Both shells are afterwards given three coats of dope, both inside and out. Brush over with fine sandpaper between each coating of dope.

Cut out a small door from one side of the fuselage. The piece of wood which is removed cannot be used for the door, so shape another piece to fit. Use small pins for the hinges and the door knob. Join the shells together by applying cement generously along the inner sides of both halves and then press them firmly together. Place a couple of rubber bands at intervals along the fuselage to keep the shells firmly together while drying.

When this operation has been completed, small parts such as the rear wire hook, tail wheel, and parts "F-1" to "F-6" are cut to shape and cemented in the positions indicated.

The next addition to the fuselage is the cockpit enclosure. This is built up from two pieces of celluloid. The first part retaining the shape of the conventional windshield and the rear portion forming the hatch.

Thin sheet celluloid is bent to the required shape, allowing a small edge to overlap the body sides. Apply cement to the wood and glue the celluloid in place.

The frames shown on the windshield on Plate 1 may be duplicated by placing black paper strips in their respective positions.

FILLETS AND WINGS

SHAPE the fillet pieces from the blocks listed in the Bill of Materials. Inasmuch as they form a very important part of the model, they should be made with extreme care. Study the front, side, and top views of these parts as you proceed with your work. Finally apply a generous amount of cement and press the fillets in place. Allow a couple of hours for drying.

A plan view of the left wing is shown complete. By going over its outlines with a hard pencil, applied with sufficient pressure to make its shape visible on the reverse side of the page, you may then use the same plan to build the right wing panel. Twelve ribs, each cut from 1/16" sheet balsa, make up the necessary amount for both wing panels. The wing tips are cut to shape from 1/16" flat balsa and are glued at the joining ends.

Round the leading edge off and taper the trailing edge to an airfoil section. Note that rib "R-1" on both panels slants inward slightly to obtain the necessary dihedral angle.

Upon completion of the skeleton frame work of both panels, cover the wings with fine Japanese tissue. Use banana oil for the adhesive. And before dopping the wings, spray the tissue lightly with water.

TAIL AND LANDING GEAR

THE TAIL surfaces are made from 1/16" by 1/8" sheet balsa. An exception, however, is made for the inner rib of the stabilizer parts. This rib is marked "S-1" and is cut to shape from a piece 3/16" by 3/16" by 1/8". The thicker outer-edge gives more cementing area when the stabilizer halves are joined to the body sides. Apply glue carefully at all joining ends, keeping the parts flat until they are thoroughly dry—this will prevent warping. The tail surfaces are covered on both sides and prepared for dopping in the same manner as the wings. But dope only *one* side at a time.

The landing gear legs are made in two parts. The lower parts, "LG-1", are cut to shape from hard balsa. A razor edged blade can be of great help in this operation. Study all three views and get a clear picture in your mind before starting on this work. The upper portions, "LG-1a", are carved to shape from separate pieces and streamlined. It is cemented to "LG-1".

Part "LG-2" is cemented to the landing gear in the position shown on the plans.

TO MAKE THE PROP

CARVE three blades to shape from 3/16" sheet balsa. Then join them at the center with glue, and then re-inforce additionally by cementing small triangular blocks between each blade (see drawing on Plate 2). The rear of the spinner nose-block is carved away to accommodate the hub of the prop. Apply cement to both prop-hub and the back of spinner cap, and press 'em flush together. Allow plenty of time to harden.

For motive power use six strands of 1/8" flat Para rubber. Fasten an "S" hook to each end of the strands.

(Continued on page 80)

Bill of Materials

(All wood is medium balsa except where otherwise specified)

Two blocks soft balsa 1" by 3 1/2" by 15" for fuselage;
Two strips balsa 1/8" by 1/8" by 8" for leading edges;
Two strips balsa 1/8" by 3/16" by 8" for No. 1 spars;
Two strips balsa 1/16" by 1/8" by 8" for No. 2 spars;
Two strips balsa 1/16" by 1/8" by 8" for trailing edges;
One sheet balsa 1/16" by 3" by 36" for wing ribs, tail surfaces, etc.;
Two pieces soft balsa 1 1/2" by 2 1/4" by 7 1/2" for wing fillets;
One piece balsa 1 1/4" square for propeller spinner;
Two pieces hard balsa 3/8" by 1 1/2" by 1 1/2" for landing gear part "LG-1";
Two pieces hard balsa 1/2" by 5/8" by 1" for landing

gear part "LG-1a";
Two pieces hard balsa 1/4" by 5/16" by 1 1/2" for landing gear braces "LG-2";
One block balsa 1" by 2" by 6" for parts "F-1" to "F-6" inclusive;
Three pieces hard balsa 3/8" by 1 1/8" by 3 1/4" for prop blades;
One length .020 wire 6" long for wire fittings;
Bottle of clear cement, banana oil, 1 sheet jap tissue, colored insignia, large bottle of aluminum paint celluloid, small bottle black paint, six feet of 1/8" flat rubber, and two copper washers.

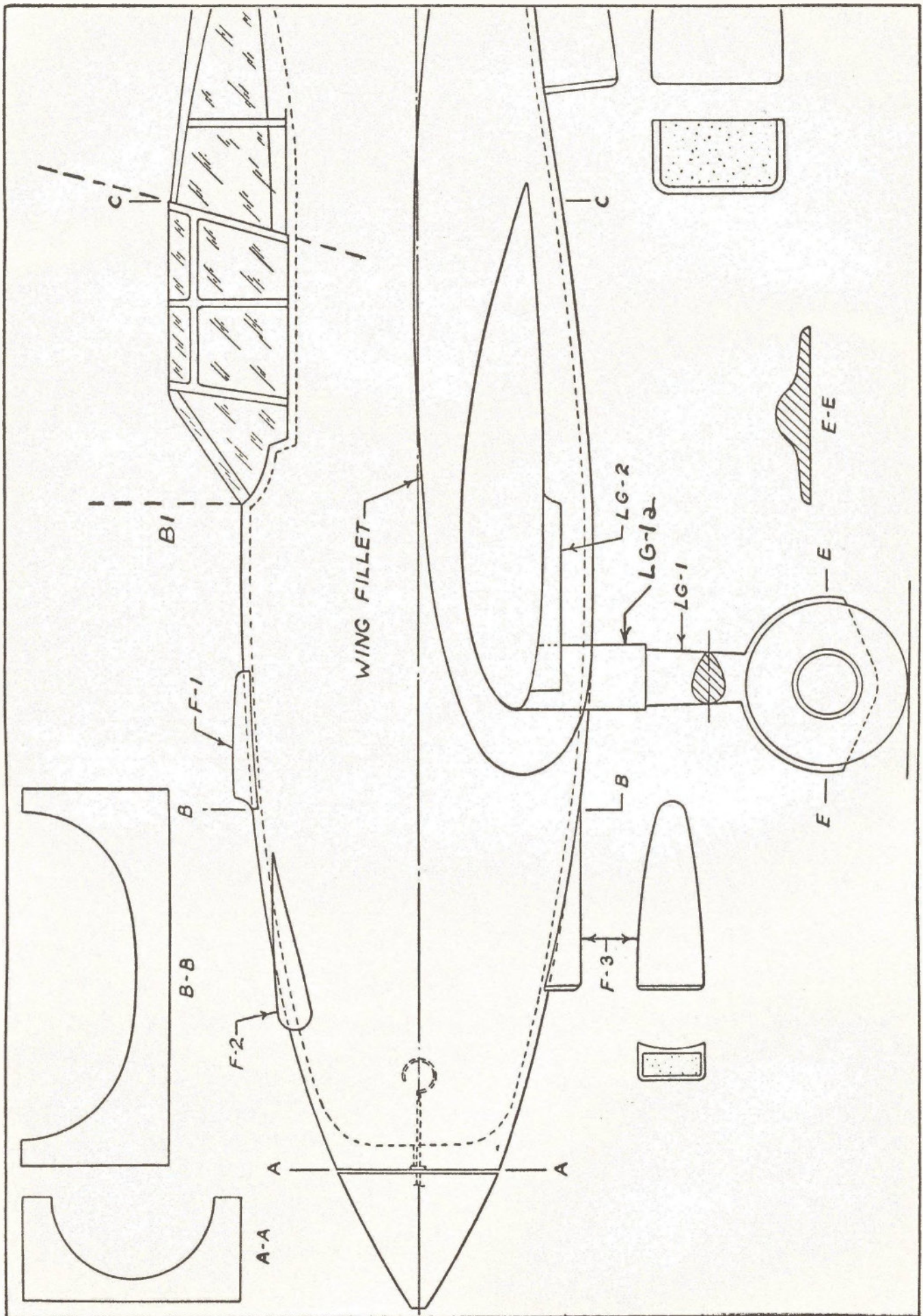

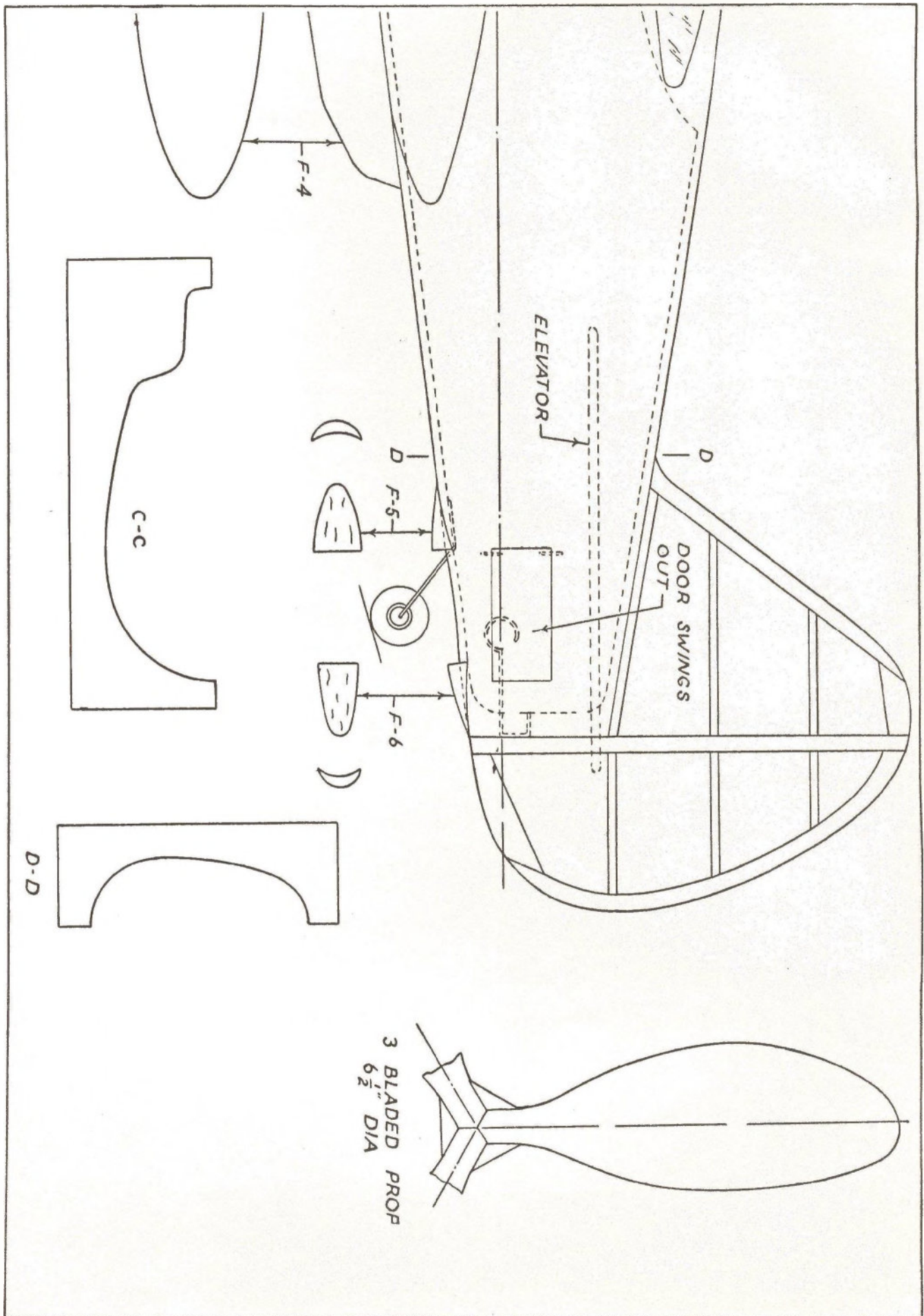

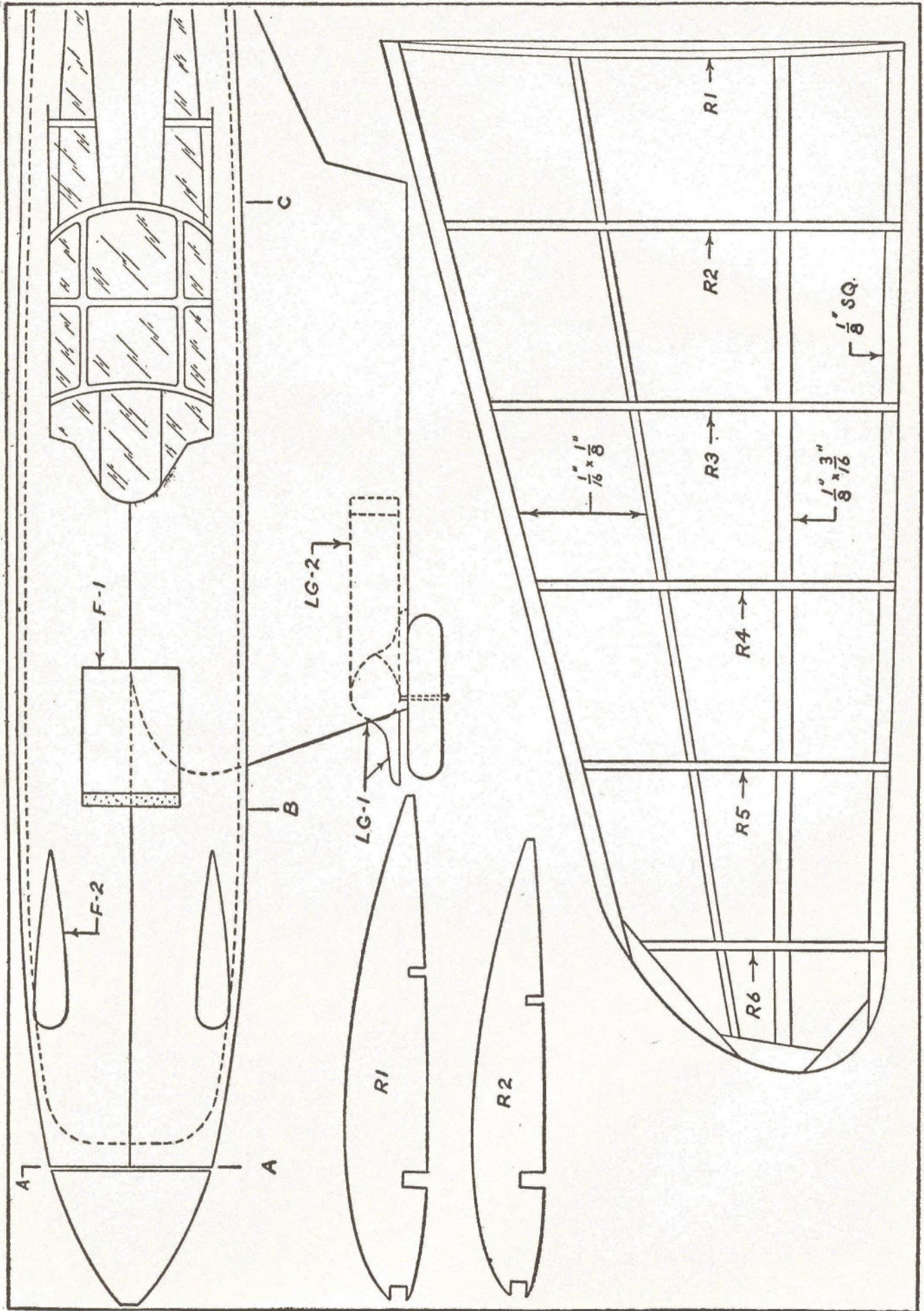

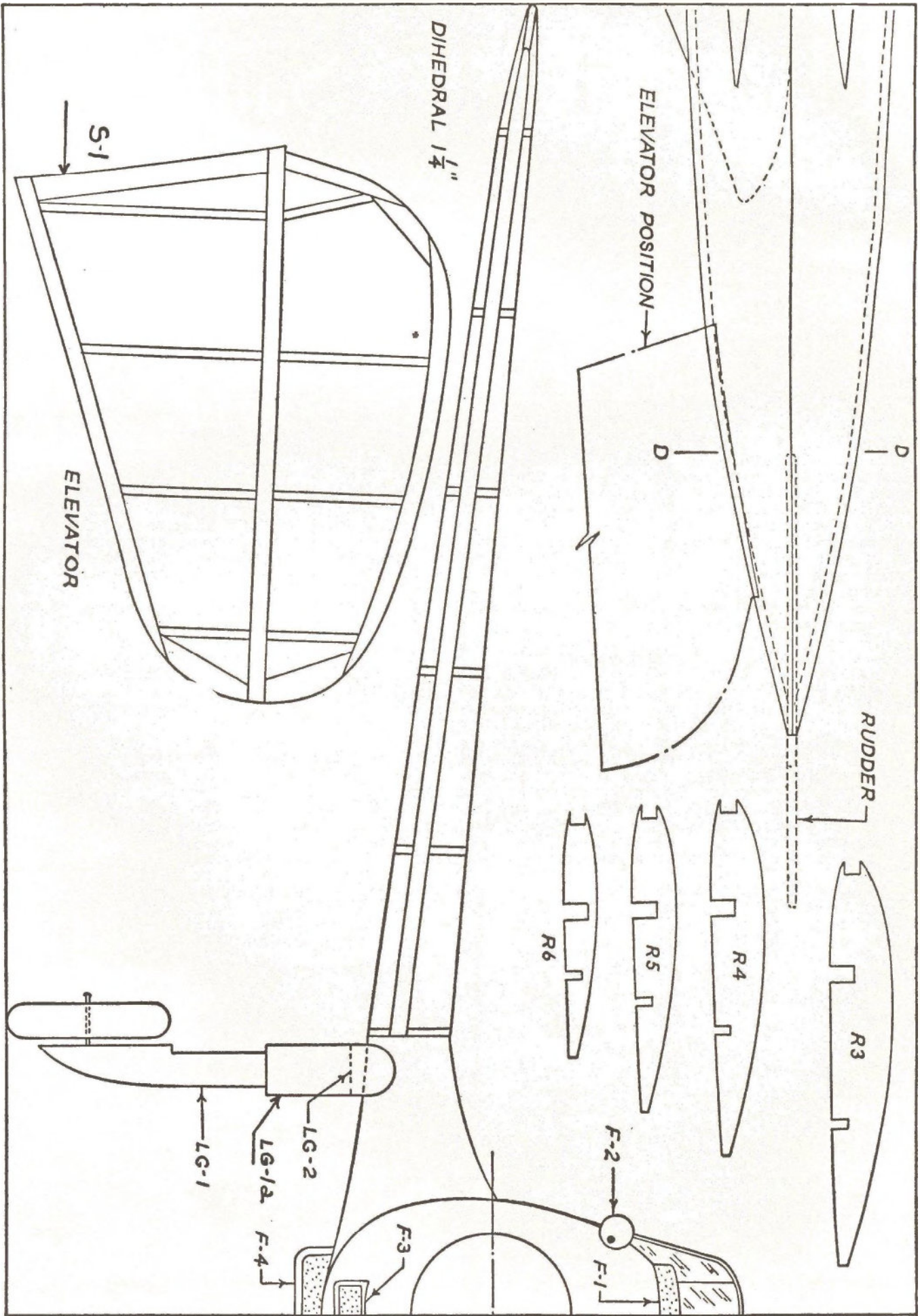

Build The

Hütter H-17 Sailplane

There's probably a swell thermal rising over the vacant lot down at the corner right now. So why not take advantage of it? All you gotta do is grab your balsa and turn out this extra-special corking soarer—and you'll be all set to go. Nick Limber tells you how right here in this snappy article.

Take 'er away, Nick!

ALTHOUGH MAN flew in motorless craft long before the Wright brothers made their first hop at Kitty Hawk, it is within recent years that the art of gliding and of glider design has taken real root and been recognized as an important branch of aviation. The Treaty signed at the end of the World War is said to have had the greatest influence in the development of the glider, for when the German aviation enthusiasts were prohibited from building large numbers of powered aircraft they turned to motorless ships in a big way.

Many excellent gliders have been produced since then. And among the best is the Hütter H-17, designed recently by Ullrich Hütter. Primarily developed for flight training, this craft features exceptionally light but sturdy construction and long, flat glides.

It is stated that the machine has attained an altitude of 800 meters and remained in flight for 3¼ hours. This performance indicates the exceptional properties of the ship. Undoubtedly, if sufficient care is exercised in constructing your miniature, ace-high flights will be attained from your model tarmac, too.

CONSTRUCTION OF THE FUSELAGE

IN CONSTRUCTING the fuselage, the modeler should first build the framework structure and to this cement sheet balsa formers, in order to shape the top and bottom of the body. Strips of 1/16" sq. balsa are used for the framework. Formers, shown on Plate 2, are traced onto 1/16" sheet balsa. After cutting these from the sheet, cement them to their respective places, as indicated in the side view and cross section diagrams.

From a soft balsa block, 1½" by 5/8" by ½", shape the nose block. Formers "A" and "B" are made of 1/16" sheet balsa and cemented to the fuselage. When these have been fastened securely, the nose block is glued in place.

Using 1/32" sheet balsa, cover the forward portion and under surface of the fuselage as indicated in the first plate. The drawing clearly indicates the direction of the grain of the covering.

By Nick Limber

Photos by Sorky



Landing-skid, tail-skid, and wing-rest are now added to the fuselage framework. The tail skid is made of 1/16" sheet balsa and bamboo; the other two are carved from 1/8" sheet balsa. Number .020

wire is used for the launching hook, which is fastened to the landing skid. A pair of pointed-nose pliers are needed to bend the hook, as shown in Plate 3. It is necessary to cover the exposed portion of the hook with rubber insulation, taken from electric wire; for there will be a tendency for the hook to cut the rubber launching cord at every take-off.

TAIL ASSEMBLY

THE TAIL SURFACES are made of 1/16" sheet and 1/16" square balsa, formed as shown on Plates 1 and 3. Trace the outline of the surfaces onto the sheet balsa and cut them out. Then cement the strips in place and allow the cement to harden. It is advisable to place a flat heavy object over the assembly to prevent it from warping while drying.

Cover the units with tissue, using banana oil to attach the paper to the frame.

FORMING THE WING

EACH RIB should be traced onto a sheet of 1/16" balsa, cut out, and sanded to shape. Note that twenty-six "C" ribs are required, and only two of each of the others. Ribs shown on Plate 2 are full size. The plan view of the wing assembly, however, is not actual size.

The wing is constructed in two halves. Measure the required length for spars, leading-edge and trailing-edge, and cement each rib in place. Note that a 3/4" gap is allowed between ribs. Shape the wing tip from a strip of bamboo, and, after the cemented joints of the wing structure have hardened, glue it in place. The forward portion of the structure is covered with 1/32" sheet balsa. This covering extends from the upper spar, around the leading-edge to the bottom spar. The rest of the wing is covered with tissue.

Cement both sections of the wing together after
(Continued on page 51)

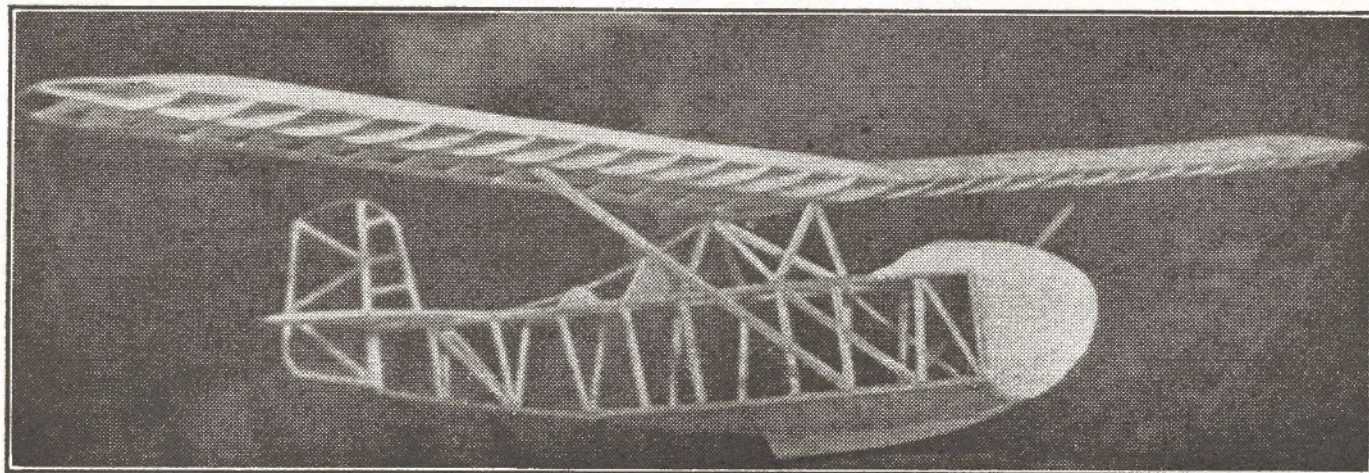

This skeleton shot of our slick Hütter model will help you a lot with your construction. For it shows the assembly of the job in clear-cut, detailed fashion. Those rectangular and triangular formers will be easy to make, fans. And look at that wing! Why, it's just about strong enough to take one of those fancy weight tests the Army's master thinker-uppers put on the real-plane test schedule!

HERE'S THE HUTTER CLOUD-HURLER—Plate 1

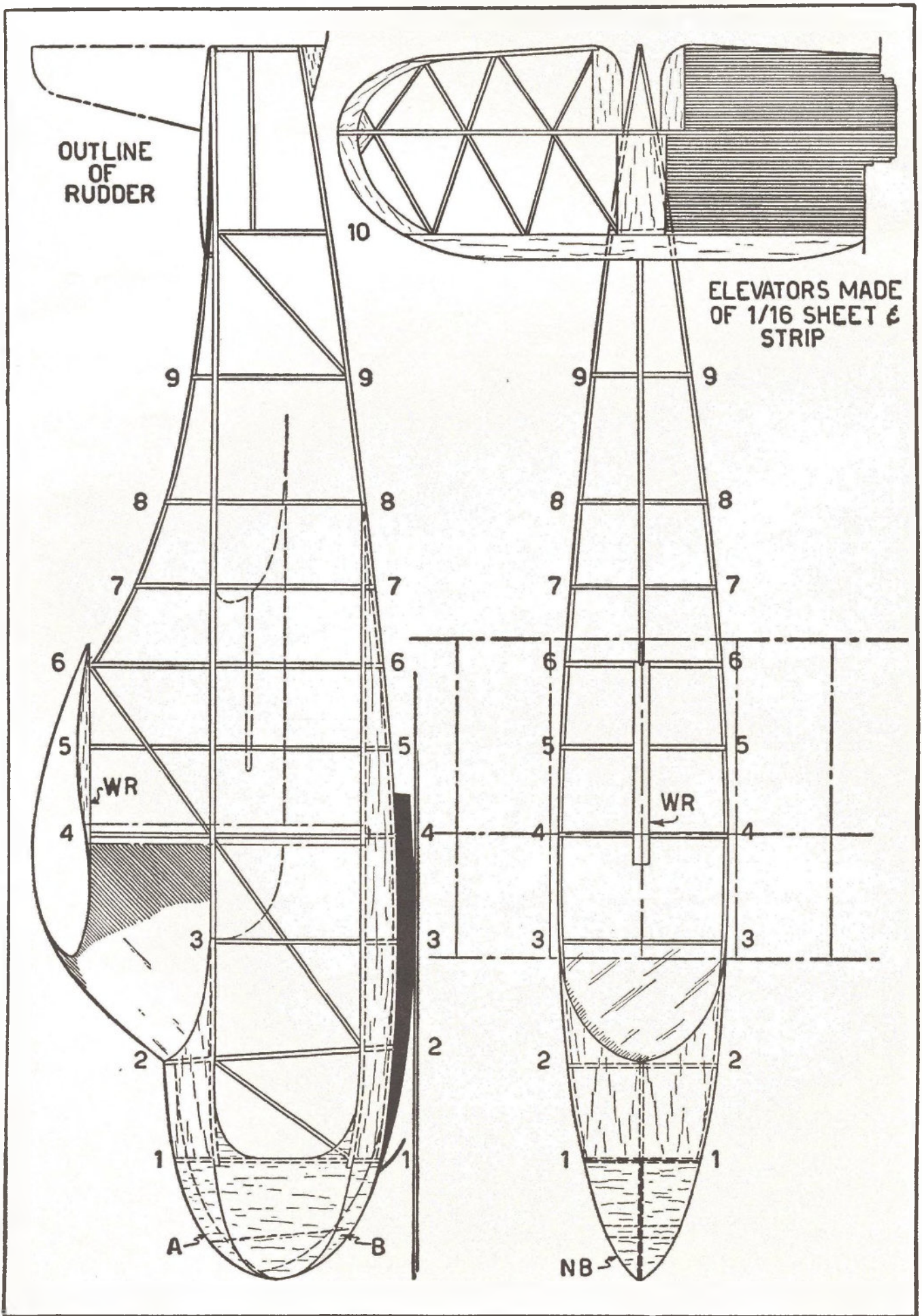

HERE'S THE HUTTER CLOUD-HURLER—Plate 2

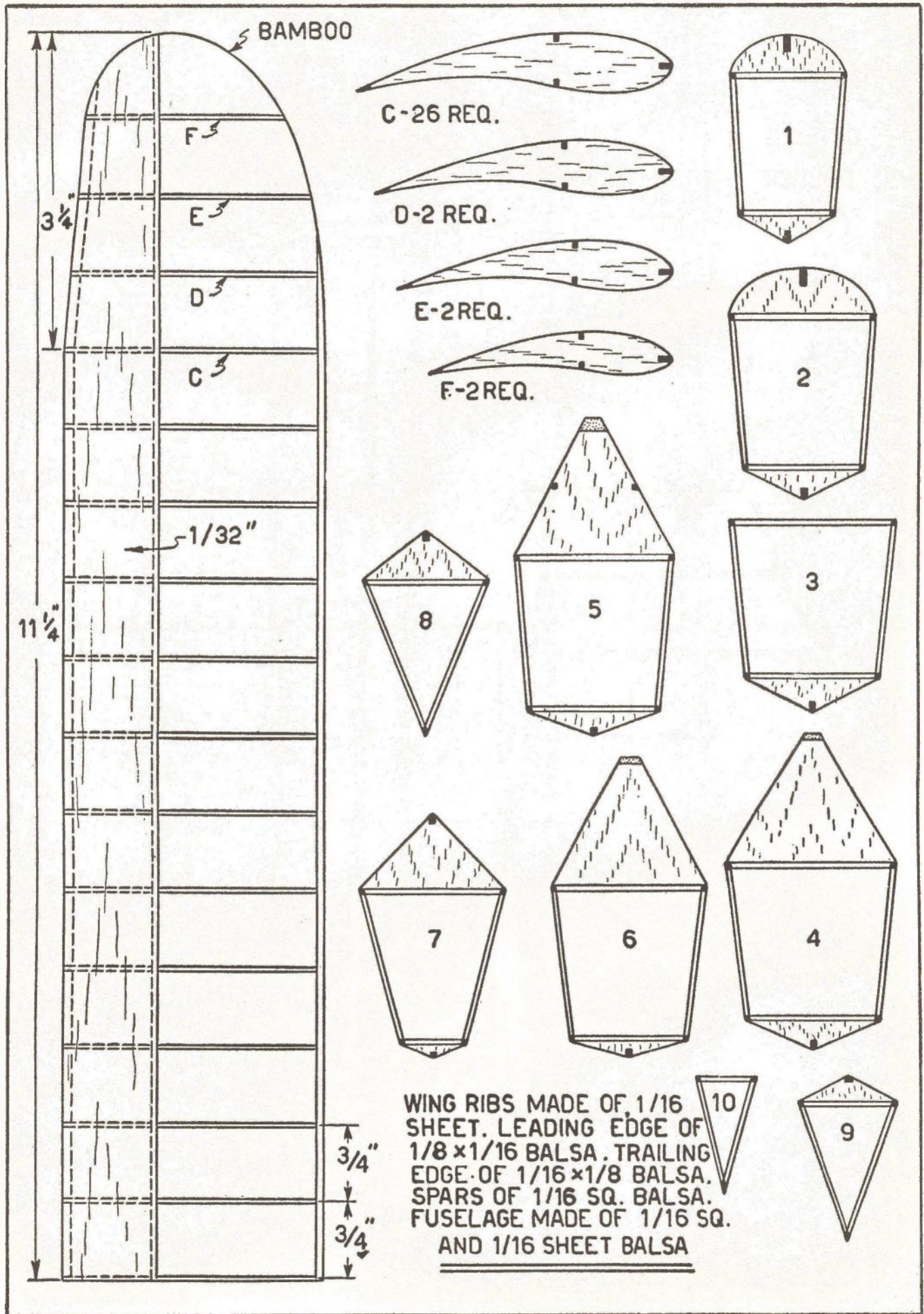

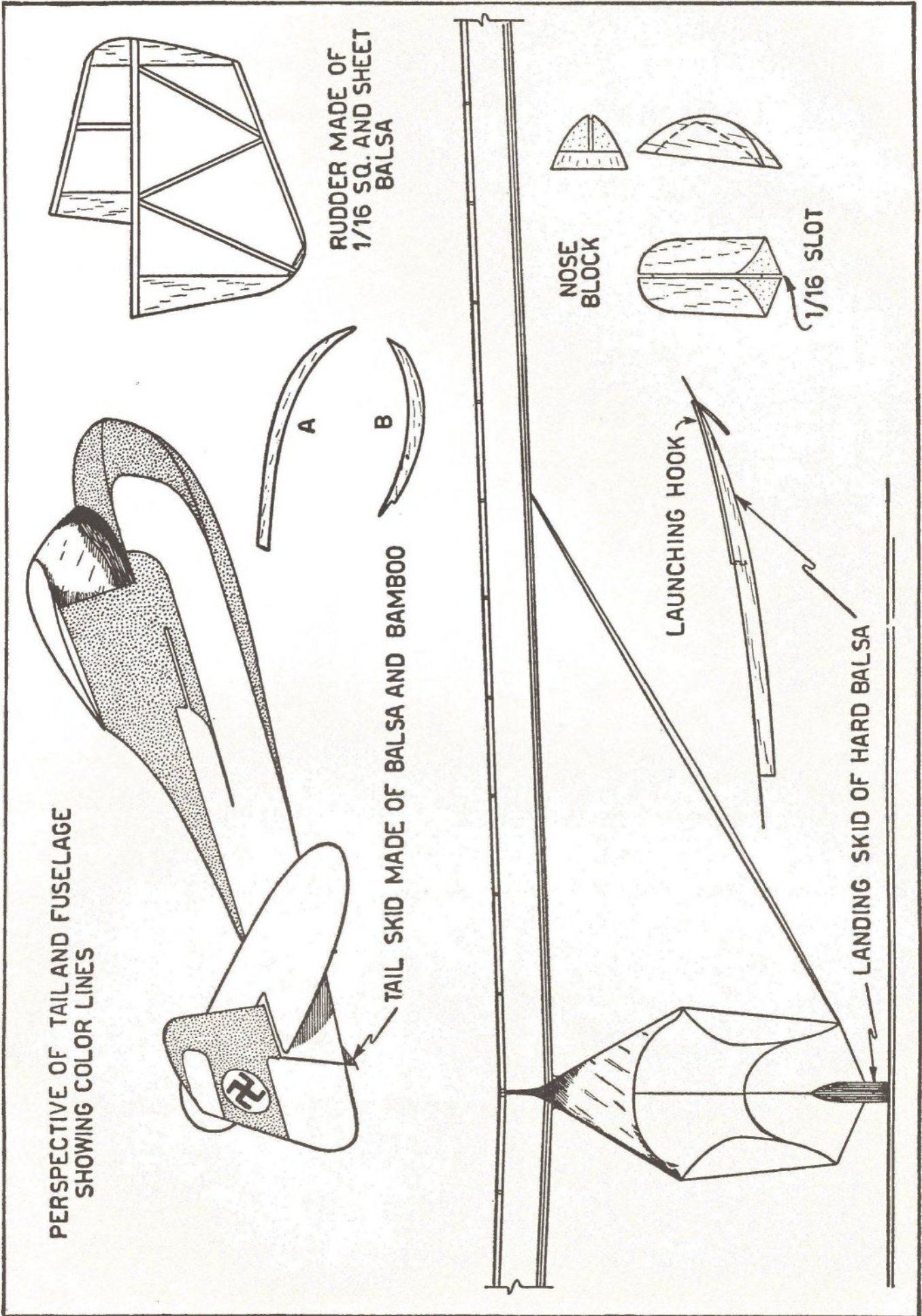

News of the Modelers

NEW YORK GETS WAKEFIELD

THE Greater New York Chapter of the NAA will sponsor this year's Wakefield International Trophy Contest at the New York World's Fair.

For the fifth time out of the 11 years that the Wakefield event has been held, the cup was won last year by an American, Jim Cahill, of Indianapolis, being the 1938 victor. Thus this famous international contest will be held in the United States this summer.

An invitation has been extended by the NAA to all nations to send their teams to compete. Those fortunate enough to place in their country's National Elimination Contest and bring home a winning prize will be feted at the Fair as they never have been before, according to the NAA. A gala program of entertainment and sight-seeing has been arranged for the visiting teams.

Irwin S. Polk has been named Wakefield International Trophy manager. Model aeronautic officials of all nations are invited to declare their intent to participate by writing to Mr. Polk, at 429 Seventh Avenue, New York City.

NATIONALS SLATED FOR JULY 5-9

THE 12TH. National Model Airplane Meet will be held in Detroit, July 5 to 9. And this year's tourney promises to surpass even last year's contest, which was widely acclaimed as the best ever held.

The contest again will be sponsored by the Exchange Club Council of Detroit, which consists of 28 Exchange Clubs in that district.

Arthur J. Vhay, Operations Officer of last year's meet, has been appointed General Director of the 1939 Nationals. Irwin Polk once more will act as Meet Manager.

An insignia competition, similar to that held last year, is again planned. So those who are "artistically" inclined may now start doping out an insignia which will symbolize the work that the National Exchange Clubs and the NAA have done for aviation-minded model builders.

H. A. Thomas, of Little Rock, Arkansas, was the winner of last year's insignia competition. And his design was incorporated in the official insignia of the meet.

N. Y. CONTESTS PLANNED

THE Metropolitan Model Airplane Council, composed of model clubs in the New York area, has announced its gas model program for the coming year. The first meet will be held on April 2, using the new NAA rules. There will be the regular endurance event and a special event for novelty ships and radio controlled models.

An invitation seaplane event will be conducted in August. But the site of this contest has not been decided upon as yet.

Another invitation meet has been scheduled for September.

The Council is conducting a census under the supervision of Louis Garami to determine the trend in model building in the New York area. In this manner information as to whether model builders are swinging toward gas models, endurance models, or gliders can be determined in advance and activities planned accordingly.

A survey is also being made to determine which fields are available for power model flying in the vicinity of New York City. When this survey has been completed, the Council will seek assistance of City and aviation officials to obtain a suitable field for the petrol job flyers.

Model airplane clubs, rubber or gas, are invited to join the M.M.A.C. for participation in the various activities.

NEW GAS MODEL RULES

HERE are the new NAA rules for gas model competition:

Engine run reduced to 20 secs.; for non-competitive flying, the engine run remains at 30 sec; any run of less than 40 sec., or an engine run of less than 20 sec., shall be considered a delayed flight; and, instead of the highest time of three official flights, the total of all official flights shall serve as highest time in contests.

Three separate classes were established with the following wing areas: Up to 225 sq. in.; from 226 to 450 sq. in.; and over 450 sq. in. The cubic displacement of the power plant shall be

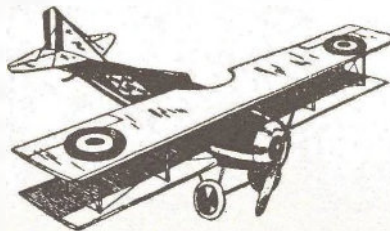

restricted as follows: In the first class, no engine with a cubic displacement of greater than 0.20 may be used. In the second division, engines must range in displacement from 0.20 to 0.30. In the third division, all engines over 0.30 may be used.

Other measures that were passed by the board were these: The 8 ounce per sq. ft. ruling has been retained; a duration record cannot be established unless the time is 2% greater than the present existing official record; class "E" for R.O.W. gas models has been added.

WIN F. A. SUBSCRIPTIONS

LATE in December the Gas Model Airplane Association of Southern California held a huge contest in which there were 293 official competitors. And these fellows declare they set something like a record by turning in 440 official flights between 7:30 a. m. and 1:30 p.

m., with a 45 minute recess called at eleven o'clock.

Four subscriptions to FLYING ACES were donated to the following winners: Frank Jeffers, of Los Angeles; E. A. Stockton, of Avenal; Elbert Weathers, of San Diego; and Clarence Moffet, of Los Angeles.

Altogether there were 83 prizes awarded. Some of the top-flight modelers were: Leslie Zeiders, 10 min., 20 sec., with a motor run of 28 sec.; Dean Banks, 9 min., 55 sec.; E. J. Brown, 6 min. flat; Bob Bowers, 4 min., 50 sec.; Kay Butcher, 2 min., 24.5 sec; Bob Huber, 2 min., 15 sec.; and Sandy Abrenica, 1 min., 5 sec.

C. W. Hess took first place in the low-wing event. His time of 1 min., 9 sec., gives him permanent possession of the trophy.

SCHROEDER SETS RECORD

ART SCHROEDER, Syracuse (N.Y.) Model Airplane Club member, brought national recognition to his group when he recently established a national record for junior class gas models. Art's model flew for 1 min. and 41.5 sec. in the meet, which was NAA sanctioned.

At the indoor meet held by SMAC recently, the following fellows took top places in the stick event: Al Towle, 6 min., 14 sec.; J. Chadwick, 6 min., 8 sec.; Ira Fralick, 5 min., 55 sec.; Ed Guth, 3 min., 56 sec.; Bill Hayes, 3 min., 35.8 sec.; and George Kesel, 3 min., 12.8 sec.

In the indoor fuselage event Bill Hayes, J. Chadwick, George Kesel, and Ed Guth were the top-notchers. Bill Hayes really went to town when his model turned in 1 min., 28 sec., to set a new city record.

"DOWN-UNDER" DOINGS

LATE reports tell of a decided increase of model activities in New Zealand. An exhibit of outstanding merit was included in the recent Rose Show of New Plymouth. It consisted of a display of 25 flying models made by boys of the Te Kuiti School under the guidance of their teacher, Mr. John Allen.

WACHUSETT'S WINNERS

DURING January the Wachusett Model Aero Club, of Fitchburg, Mass., held its first meet of the new year. Howard Payea flew his Super-Flea at the tourney for the first time and took top honors. The Flea turned in consistently good flights, eventually showing its tailskid to other contestants with a flight of 37 sec. Art Hamieson, one of the newest members, placed second. Joe Cushing copped third.

The Fitchburg group also announces that they will hold another of their "Fly-For-All" meets on April 2nd. A prize will be awarded to the modeler who turns in the longest flight—regardless of what type rubber-powered model he may use. All are welcome to attend.

HERE'S THE BELLANCA FIGHTER-BOMBER SOLD TO CHINA!

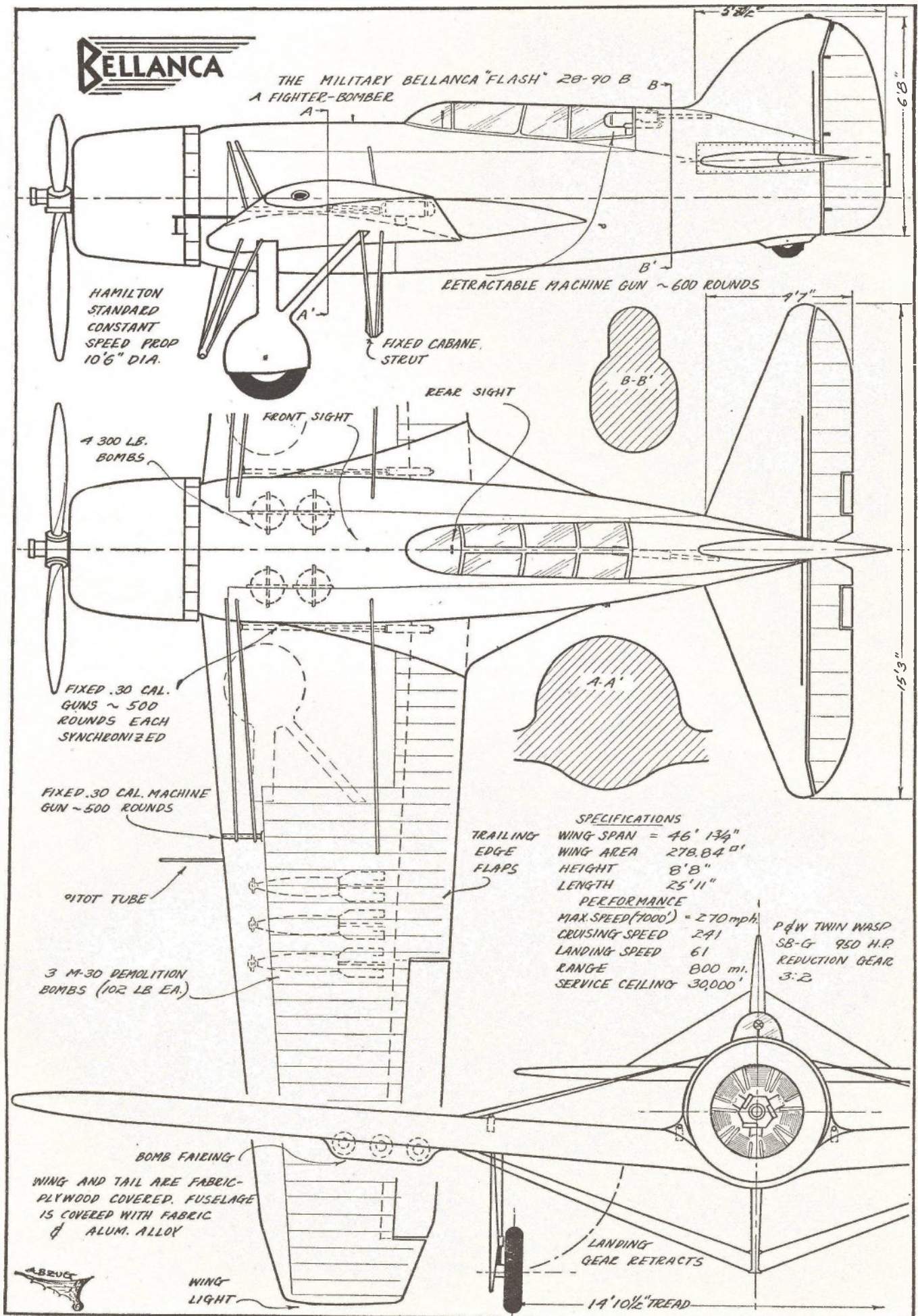

Fit Your Gas Job

With Knee Action

HERE'S a simple system that'll insure easier set-downs for your gas buggy. And the parts involved are *really* easy to build. All the materials you will need can be bought at any model supply or hardware store for just a few pennies, and if you're of the tinkering sort you might be able to find 'em in the scrap pile under your workbench.

This nifty little "knee action" gear flexes backwards as well as up. Those are its important characteristics, because gas models land at undiminished gliding speed—not at stalling speed as man carrying ships do. And, what's better, the gear is practically indestructible, because it does not *resist* shocks—it *gives with 'em!* So you fellows who don't have a smooth field to fly your models from needn't worry about set-downs any more, and you can continue to fly 'em from your back-yard. For this gear really thrives on bumps!

During the development stage on our own job, we dropped the fully loaded plane directly down from about three feet. The gear flexed outward and took the shock neatly. Later on, when the job was completed, we gave it a few field try-outs. We tested our knee action system by attaching a cord to the nose of the plane and then running across a rough field pulling the cord. There was no tendency for the plane to swerve or bob out of its path as it met obstacles.

But before we begin construction, here's the materials you'll need for the knee action gear: Four inches of $\frac{1}{8}$ " diameter piano wire (larger or smaller, according to model); one piece of $\frac{1}{4}$ " by $\frac{3}{4}$ " brass bar; ten number 2-56 bolts and nuts; ten square inches of tin (cut this from any old soup can); one length of $\frac{1}{4}$ " copper tubing; two feet of .22 gauge soft iron wire; four $\frac{1}{8}$ " washers;

By Gordon Reeves and
Oliver Steigerwalt

Did YOUR gas buggy ever hit the rough ground for a convulsive jarring landing? If it has—and we know it has—you'll want to fit your cloud comber with this efficient K.A. gear. It's simple as all heck to build. And we're not kidding a bit when we say it'll smooth out your gas job set-downs in zipping-quick style.

two small cotter pins; and one dozen $\frac{1}{8}$ " by 3" rubber bands. There you are—that's the entire list. Not much, huh?

But let's stop gabbing and get down to the actual construction.

STRUTS

THE STRUTS are made of $\frac{1}{8}$ " piano wire. Cut the wire to the proper lengths and smooth off the ends with a file or sharpening stone. (To save hacksaw work you might break the wire to length by filing notches, and then snapping.) Bend the wire as shown in the drawing. But be very careful you bend the wire in

small arcs instead of in sharp bends.

Heat the lower ends of the rear struts to a cherry red, then flatten them with a hammer. Drill the hammered portion close to the end, using a $\frac{3}{32}$ " drill. Then put the struts aside until you begin assembly.

PIVOT AND SLIDING GEAR

CUT TWO pivot-blocks for the inner ends of the axles (from your brass bar) and file 'em to shape. The holes for the front struts are drilled to $\frac{1}{8}$ ". Slot the blocks with a hacksaw, then drill $\frac{3}{32}$ " holes (see drawing) to mount the rear struts.

The four slider-blocks are cut out and filed to shape. Drill two parallel holes in each block $\frac{1}{2}$ " apart, using a $\frac{9}{64}$ " drill—one hole in each block only half-way through. Remove any rough edges with a file and sandpaper to prevent their cutting the shock absorbers.

ASSEMBLY AND ADJUSTMENT

LAST on the list comes the assembly and adjustment of the finished parts. Clean all the strut ends and coat them with a film of soldering flux. Heat the soldering
(Continued on page 80)

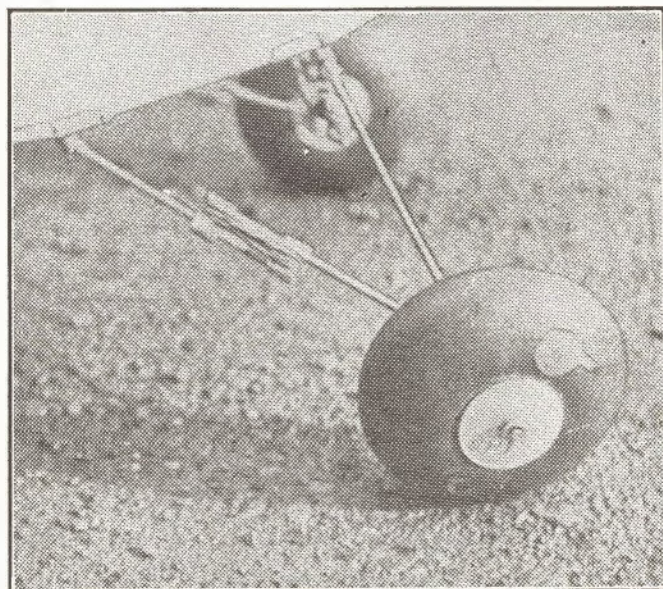
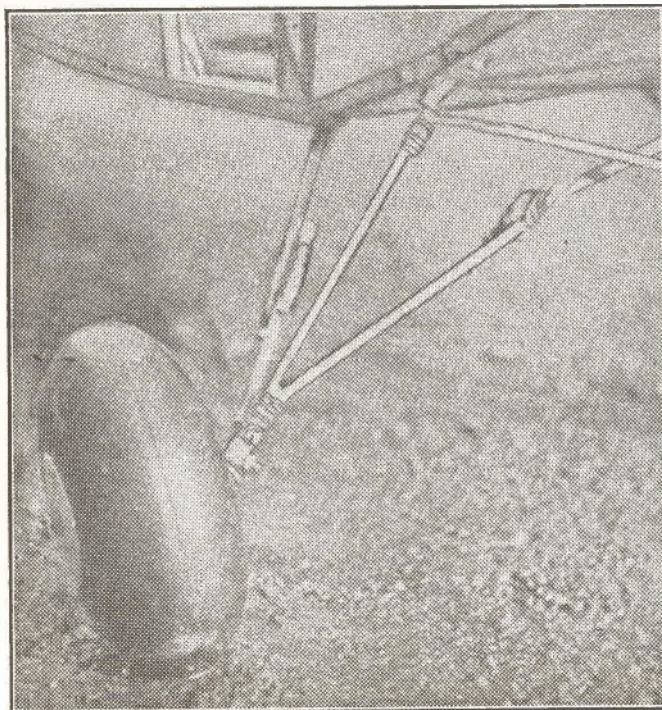

These two close-ups show the knee action apparatus on the authors' own ship. Above: That neat dog biscuit-shaped gimmick on the rear undercarriage strut is the whole works. Just like the shock unit on a regular plane, it gives when Mama Earth receives your model—springs 'er into even keel. Left: This shot shows the gear in head-on view.

HOW TO MAKE THIS SIMPLE K. A. GEAR

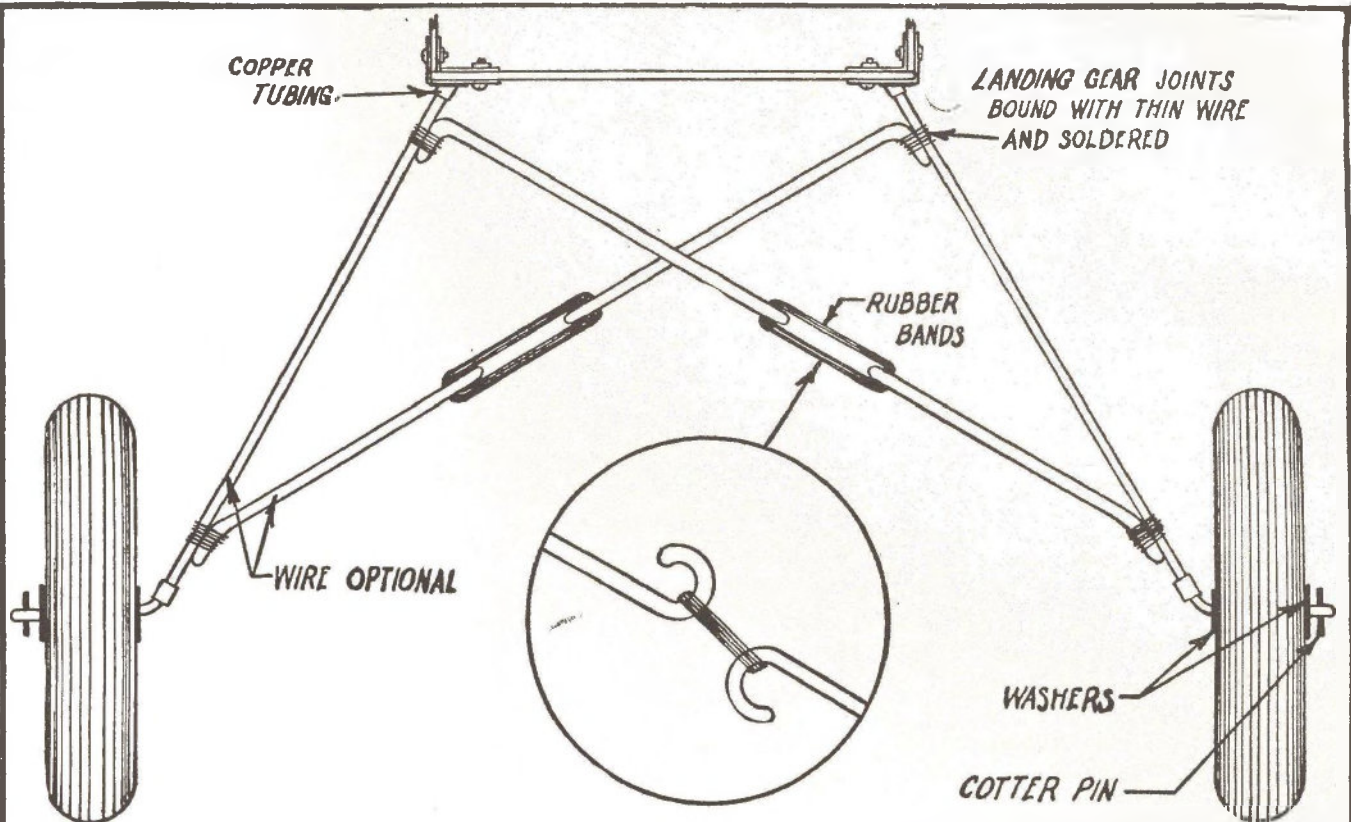

FRONT VIEW

NOT TO SCALE

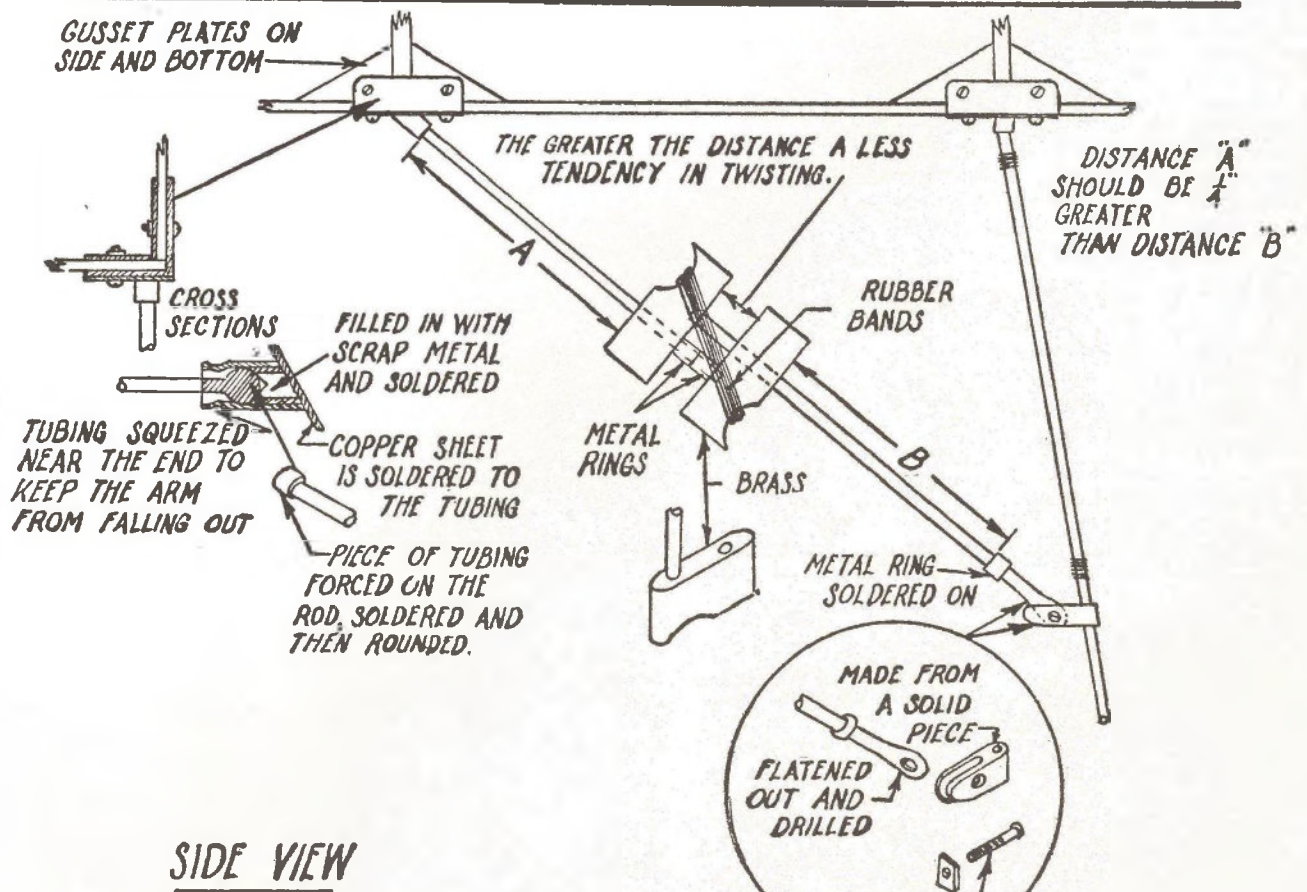

SIDE VIEW

DRAWN BY - LEONARD WIECZOREK

How to Select

The Correct Engine

"Gollern it t' blazes!" is only a mild variety of the cussin' you hear when a gas modeler has doped out a swell ship—and then can't figure out the right engine to put in 'er to get the best performance. "Shall I power her with a Propwash Ace, a Baby Whatzis, or a Mighty Mazurka?" That's always been the big question. But now Phil and Ben have kicked through with a simple method of getting the answer before you can say "empennage." And here y'are—

By Phil Zecchitella
and Ben Shereshaw

OBSERVATION at a slew of model meets has focused our attention on the fact that many models are ill-planned. The horsepower was either too much or too little, or the wing area was too great or too small. It seems that many potential gas modelers lack the necessary rubber-model experience to guide them in their selection of a correct combination of model and motor.

In order to correct this tendency in beginners, we have evolved an interesting aspect of what are called Nomograms—charts enabling you to find an unknown factor in graphical fashion.

If you have a model, you already have figures representing the weight and the wing area. And with these two figures, the chart gives us a graphical means by which to determine the proper engine with which to power the model.

A freak ship, say one with a 300 square inch wing area and a 1/5th horsepower engine, can be flown. But because it is a freak arrangement the chart will not show any figures. Thus the chart acts as a brake to goofy designs—by not registering.

The Nomogram consists of three tabulated columns, which we will refer to as "left," "center," and "right." The column to the left represents the weight of the model in pounds (including the weight of the engine). Since the chart is to determine what class of engine to use, you may wonder how you are to guess the weight of the unknown engine. But you will surely be able to judge the *approximate* weight of the engine, and when you project the solution you can add or subtract the difference.

The center column represents the wing area of the model in square inches, and the right hand column is the engine selector. This column is divided into four classes: "A," "B," "C," and "D." At the top of the drawing, all engines have been grouped into a division representing an approximation of their horsepower rating. Although a group of similarly rated engines may vary slightly in horsepower, this variation will not cut any ice.

It is assumed that the modeler using this chart already has a gas model kit or a gas model design. In this case, the graph will serve to show an optional number of engines that may be best suited to the performance of the model. If the model is already constructed, you can easily figure out the wing area and the weight of the model. And by marking these two points in the proper columns, draw a straight line with these two points into the right hand column. If the line intersects the "C" portion, then you have a choice of any class "C" engine listed at the top of our Nomogram. If we left out any particular engine in which you are interested, simply check its horsepower to determine its classification.

If the line intersects the motor selection column close to a division of another class, it is advisable to use the larger engine. It is better to use a little more power, than not quite enough.

The dotted lines on the chart represent three problems which will serve to illustrate how the chart works:

Problem "A" is the case of a model weighing 7 pounds (see left column)

and having a wing area of 1,750 square inches (see center column). The solution is in group "D" (see right column). Problem "B" is a model weighing 5½ pounds with 1,000 square inches of wing area. The chart solution calls for an engine in class "C". Problem "C" is a model weighing 2 pounds with 400 square inches of wing area. The answer to this is an engine in group "A."

Airfoil selections in the lower "A" category (Pee-Wee and Condor motors) should possess a lift-drag ratio over 20. Choose an airfoil such as those from the Gottengen family for this class. It is likewise imperative to use Gottengen airfoils in the upper class "A" engine group. (We believe Gottengens to be desirable in the other three classes, too, though modelers may try other types in these categories if they wish).

IF YOU have an engine without a model, and are in doubt as to how large or what type of ship to build for it, you may reverse the procedure by working back from the right hand motor column. With a fixed point on this column representing the type of engine you may have, move a straight edge up and down the left column, pivoting from the fixed point of the engine column in arc fashion. By doing this you will have a number of possible combinations from which to choose from.

Let us assume you have a 1/5th horsepower engine—a class "B" power plant. Place the straight edge at any point in the "B" division of the right motor column. In pivoting from that point, the extremes in the model weight column allow you to build a model weighing 1 pound with 900 square inches, or a model weighing 10 pounds with 350 square inches. These are freak combinations if there ever were any!

Why do these combinations show up here? Well, the chart has been primarily designed as an engine selector, to read from left and center columns toward the right. When used in this manner, no crackpot arrangements are possible.

As a check to keep you from running into this sort of thing, a maximum wing loading should be first established—one *not* to exceed 13½ ounces per square foot of wing area.

You can determine wing loading, in pounds, by dividing the weight of the model by the wing area. Multiply by 16 to get it in ounces. The ideal wing loading should be about 8 ounces per square foot. This, incidentally, will also keep you within the new NAA gas model rules. Since the overall efficiency of a model decreases proportionately to the wing area of the model, a larger model will have better flying and soaring characteristics.

And now, fellows, rip out our Nomogram accompanying this article—Shereshaw's Motor-Choosing Chart—and mount it on cardboard. Then put it in your file for future reference. You'll find it'll come in very handy.

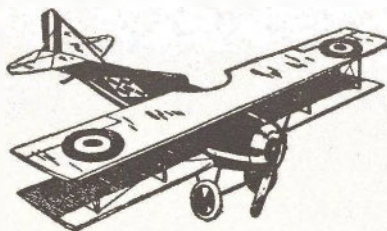

Shereshaw's Motor-Choosing Chart

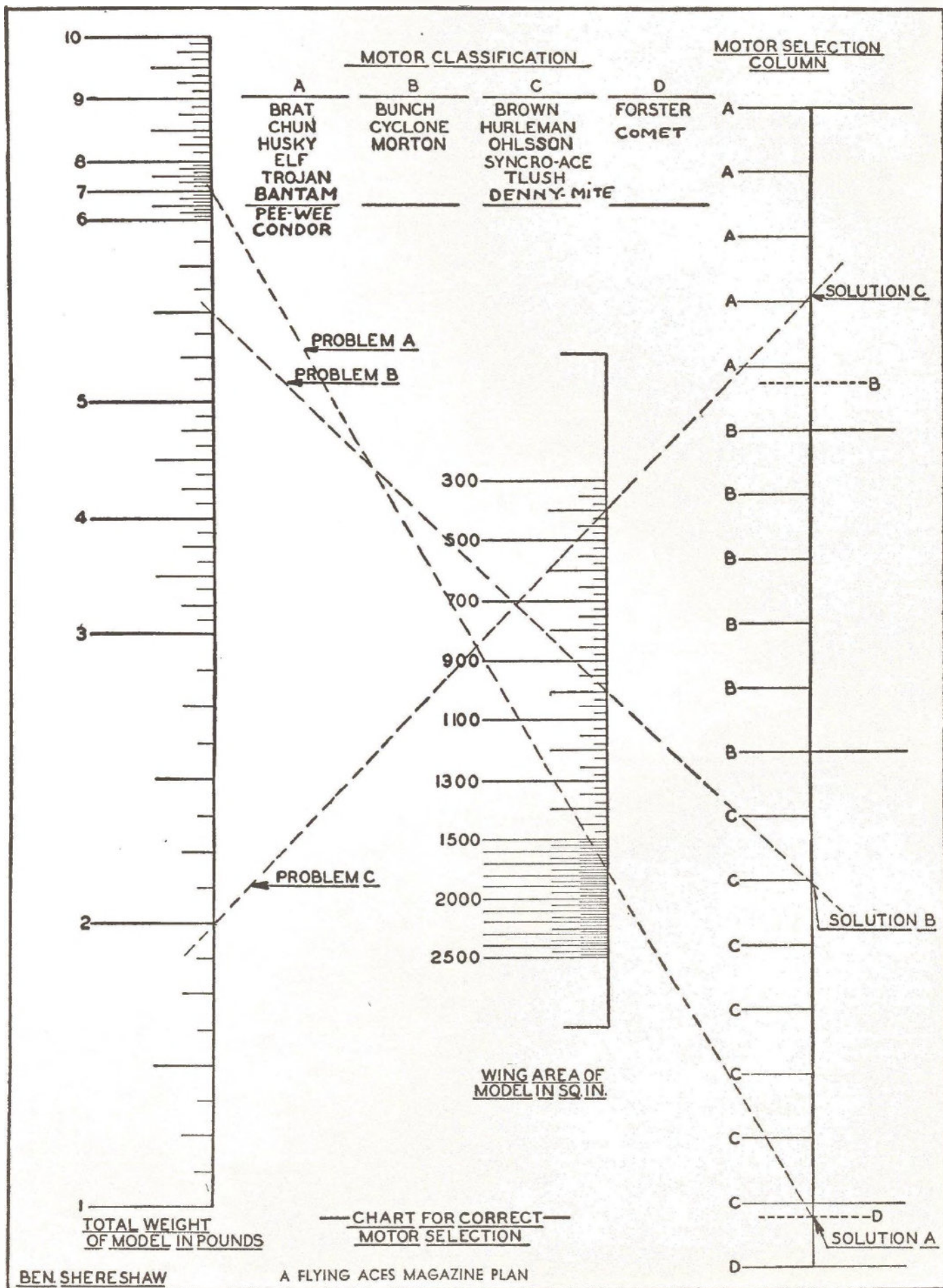

From the Model Builder's Workbench

* * *

REALISTIC VICKERS M.G.

HERE is a swell plan for constructing machine guns for your solid scale models, including a better method of making miniature cooling louvres than by scoring the wood with a pencil:

Cut a length of dowel to the desired m.g. length, then glue a small piece of 1/16" balsa to each end of it. Cut common pins (for the louvres) to the right length to fit snugly between the pieces of 1/16" balsa and glue them to the dowel. When all the pins are glued firmly in place, sand the 1/16" balsa pieces until they are round—a little larger than the size of the dowel.

After this work has been completed to your liking, glue a piece of rectangular balsa to one end, attach a cocking handle—and you'll have a very realistic Vickers gun.

—ADOLF BUTOR

PAPER SPINNERS

A PROP BOSS, besides adding "class" to a model plane, also protects the prop from being broken in a head-on crash. The spinner described here is for the fellow who does not have the mate-

rials at hand for making a carved balsa one, or does not wish to try the carving job.

A compass, scissors, sheet balsa, and heavy paper, or light, flexible cardboard, together with model cement and dope, are the materials needed.

For a one-inch spinner, mark a circle with a one-inch radius. Cut it out, and make a slit to the center. Shape the disc into a cone and cement the flaps together. Cut the balsa disc to size and cement in the bottom of the cone. Then sand the seam up the side until the cone's surface is smooth.

Shape the center of the prop so the sides are vertical, then cut the cone and base to fit. Cement firmly in position and dope it thoroughly to match the prop.

Spinners are best if the prop center is carved to match and the spinner cone merely cemented on the front.

For gas jobs, the cones can be made from thin sheet aluminum with small pierced flanges at the base for fastening to the front of the prop with small nails or screws, making removal of the air-screw possible.

—JOHN DALLAIRE, JR.

BROKEN-PROP TALK

MANY of you fellows throw props away if they get broken. Actually, however, all you have to do is put a little glue on each broken part, push them together, and then pull them apart to let them dry thoroughly so that the pores of the wood will fill in prior to final cementing.

While they are drying, cut a bamboo peg to put into the broken end. After the glue on the broken ends has dried thoroughly, add another generous coat, and shove them together—the peg completely concealed in the prop and sticking into each part. This will make a very strong joint, and you may continue to use the same prop.

—ROBERT FRASER-LEE

SIMPLE TAIL SKID

SLIP the clip off of an ordinary pencil and cut off a piece of the pencil about an inch long. Remove the lead from the pencil stub by pushing it with a piece of wire or a nail. Then cut the pencil stub to an angle—about 45°—and glue it to the rear of your model. Slip the clip back on this stump, and you have a streamlined 2½" tail skid that has perfect spring action.

—WILL COLLINS

IGNITION HINT

HAVE YOU ever tried to adjust the gap of a spark plug point and then had the plug point break off? Well, I have. And, after a little thought on the matter, I fixed 'er up by bending the main electrode (the one in the center) over slightly toward the wall of the plug. The motor then ran okay with this offset spark (about 1/8").

—RALPH SAGE

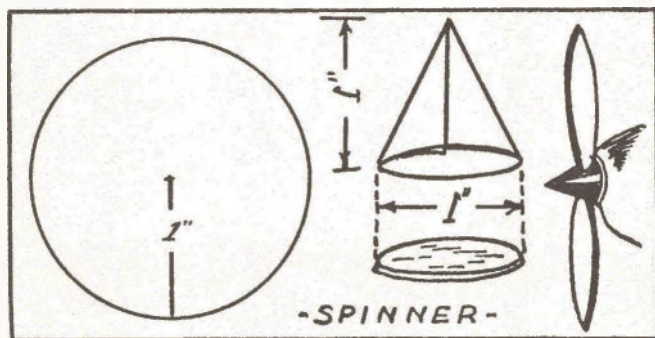

Look this plan over carefully—then make a neat paper spinner for the air-screw on YOUR model! Though the 1-inch size is given here, it'll be a simple matter to turn out these little prop dresser-uppers to your own measurements. And John Dallaire, Jr., tells you how to do it in the accompanying workbench item.

What Do You Say?

Here's your corner, buzzards, and it's open to all readers who have a model argument they want to get off their respective chests. Make your comments short and snappy, and we'll try to squeeze 'em in.

* * *

"SCRAM" BOOSTER

Model Editor, FLYING ACES:

I am very pleased to tell you that I have finished building your gas powered *Scram*. She is a beautiful flyer, and her climb is exceptionally steep. The only thing I changed on the model was the thrust line—which I placed about 2" higher. This was done because of the strong winds we have had for the last two months—I was afraid of a stall if I built her according to the design.

A few days ago *Scram* made an excellent flight. I gave her enough gas for a minute's engine run, and sent her off. She climbed rapidly, and by the time the motor cut out she had gained a good 700 feet of altitude! It glided for about twenty-five minutes, and then landed about three miles away in a patch of woods.

Scram is such a top-notch model that I'm going to attempt the South African

record in the near future.

IVAN H. TUCKER,

Johannesburg, South Africa.

YOU SAID IT, HOLDER!

Model Editor, FLYING ACES:

Regarding the Fredriksen-Mensing-Riedesel feud, it is quite possible that Riedesel's *Moth* flew at forty-odd miles per hour. Haven't Messrs. Fredriksen and Mensing ever heard of tail winds? With a good breeze of forty m.p.h., the plane could attain that speed easily—with no propeller at all! And in a good hurricane, the *F. A. Moth* could make Howard Hughes' crate look like a Jenny!

Mr. Riedesel didn't state in which direction his model flew—although it is taken for granted that it flew on a horizontal plane. Yet Mr. Riedesel might have dropped the *Moth* in a 9-G dive off of the Empire State Building, with

half a cannon ball attached to its nose. Under those conditions the ship would make forty miles per hour!

H. H. HOLDER,
Napier, N. Z.

LIKED "OL' RELIABLE"

Model Editor, FLYING ACES:

I want to take this opportunity to tell you that I think FLYING ACES is the best aviation mag in the world. I built the *Ol' Reliable* from the plans in the January, 1939, FLYING ACES. And if there was ever a swell ship, it's she! My model flew like a bird—and never turned in less than one minute duration. One time she got in a thermal and landed in a distant and strange back yard.

I built two of the *Ol' Reliable* models and both were swell. Altogether there were a total of six of these ships made from my plans—four by pals of mine.

BILL KELLETT,
Woodstock, Ont.

AGAIN THE "MOTH"

Model Editor, FLYING ACES:

I have been reading your mag for

The Hütter Sailplane

(Continued from page 40)

they're completed, forming $\frac{1}{2}$ " dihedral at each tip. After the cement has had sufficient time to harden, glue the wing to the fuselage at the wing-rest block.

A celluloid windshield cemented to the fuselage also acts as a support in joining the wing to the fuselage.

Shape the spars from 1/16" hard sheet balsa. Then cement the spars into place, making certain they are firmly anchored at each end.

PAINTING

COLOR SCHEME for the craft may be decided by the builder. It is advisable, however, to use a combination of a bright light and dark colors. Although Plate 3 suggests a color line detail designed by the author, the modeler may not use this if he does not care for it.

Colored dopes were used in the original model, as this type of paint is most available to model builders, and undoubtedly far superior to any other type finish for model aircraft. The rudder insignia consists of a black swastika in a white circle, the official German emblem. (We accidentally got the swastika aimed backwards on Plate 3—but we're sure you'll forgive us.) This may be drawn with India ink on a piece of white paper and pasted to the rudder after the unit has been painted.

FLYING

ADJUSTING the model for flight will require a certain amount of patience if maximum performance is desired. Add a bit of modeling clay to the nose or the tail of the craft until it balances perfectly when held at the wing-tips. Allow the model to glide out of your hands from an elevation of about 4 feet on its first flight. Observe the glider during this flight, and if it tends to stall add more clay to the nose.

When the craft performs a perfect glide, you are ready for the initial flight. But before launching with a rubber cord, glide the ship several times by hand. Increase the altitude of the take-off with each glide. In this manner, you may carefully observe the habits of the ship and make the necessary adjustments.

When launching the glider by rubber cord, the num-

BILL OF MATERIALS

All wood is hard balsa unless otherwise specified

Ten strips of 1/16" square balsa for fuselage and spars;
Three sheets of 1/16" sheet balsa for ribs and formers;
Two sheets of 1/32" sheet balsa for covering;
Four strips of 1/16" by 1/8" balsa for leading and trailing edge;
One bamboo strip for wing tips;
One block of soft balsa 1 1/8" by 5/8" by 1/2" for nose block;
1/8" for landing skid and wing rest;
Tissue for covering; number .020 wire; colored dope; banana oil, and celluloid.

ber of strands of rubber used will be determined by the weather conditions. For example, when the weather is calm, only two or three strands of 1/8" flat rubber should be used. If it's a bit breezy, several more strands will be needed for a proper take-off.

When launching the model with a rubber cord, the ends of the cord are fastened to stakes driven into the ground. The distance the model is drawn back when launching by this method can be determined only by actual flight experiments, but will undoubtedly be found to be approximately the same as the distance between the stakes. It is advisable, incidentally, to place the stakes at least three feet apart.

Even though a glider is not commonly thought to be an airplane, don't *you* make the mistake that it isn't when flying your ship.

Direct 'er into the wind for take-offs, inspect her after each flight, and exercise all other precautions that you use with your rubber powered models. Above all, make doubly certain that the glider is in the *exact* center of the shock cord when using the two-pole method of take-offs.

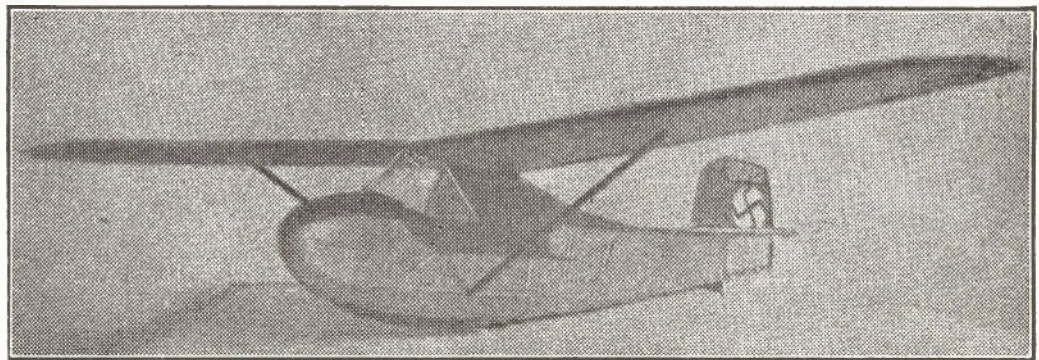

Right: And now that we've put the skin on 'er, you can see how really nifty your Hütter sailplane is going to look when she's ready for the air. Streamlining is what this job has plenty of—and it makes for top-notch flyability!

about 4 1/2 years and I think it is swell. I haven't as yet seen a model section in any magazine that comes up to yours. But say, I hear I've missed something! I didn't get the issue in which you printed plans for the *Moth*. So how's about printing it again in the near future for us fellows who missed it?

JOHN BARTEL,
Bay City, Mich.

WANTS ANTI-AIRCRAFT MODELS
Model Editor, FLYING ACES:

I am interested in solid models and have built several—mostly military. I would like to see models of anti-aircraft guns, anti-aircraft machine gun emplacements, and searchlight equipment. Why not have one of your real hot-shot

modelers make up plans for these objects?

I have read your magazine for the last six years, and I must say that I have yet to experience the time that I read an issue and found it uninteresting. From cover to cover I think you quite fill the needs for every type of fan.

HAROLD HOFER,
Chicago, Ill.

(Editor's note: What do the rest of you fellows think of the idea?)

TRYING "TRENTON TERROR"
Model Editor, FLYING ACES:

I have just started building my first gas model, which is the *Trenton Terror*, from April 1938 FLYING ACES. From

comments I have heard on this job, I knew it would be the best one to start with. And if the *Terror* comes up to my expectations, it'll be the best model in these parts!

ANDREW MARTIN,
Berwick, Pa.

ANOTHER "TERROR" MODELER
Model Editor, FLYING ACES:

The *Trenton Terror* was my first gas model, and it proved itself to be a wonder. It flew out of sight on its third flight, and I didn't find it until the next morning. Here's to more models like the *Terror*!

KEN COLEMAN,
Elkton, Pa.

Detailed Plans of the Wartime Junkers J.1

(Especially Reproduced From Our Files For You World War Fans)

THE JUNKERS J.1.—Plate 1

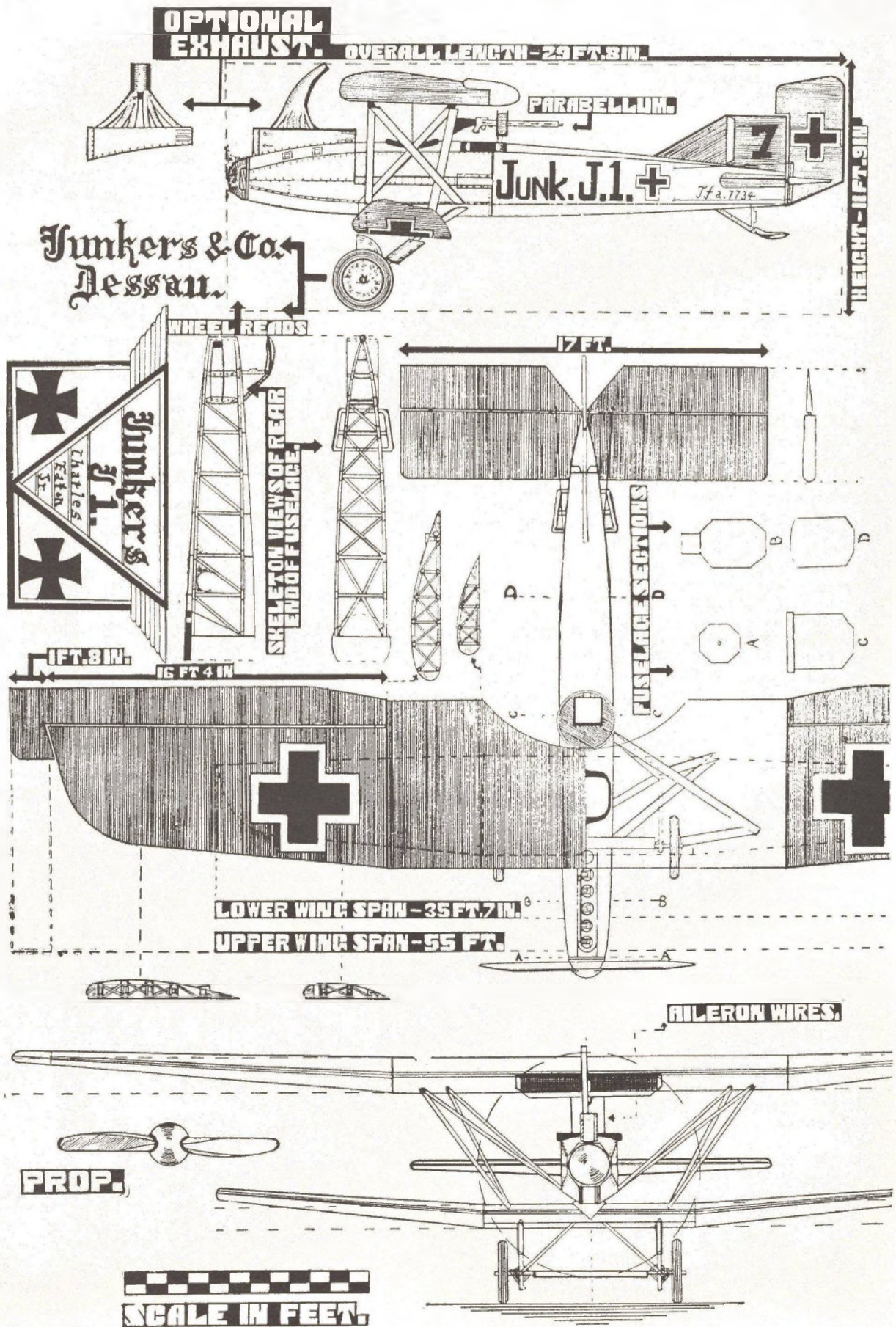

CONTROL SYSTEM.

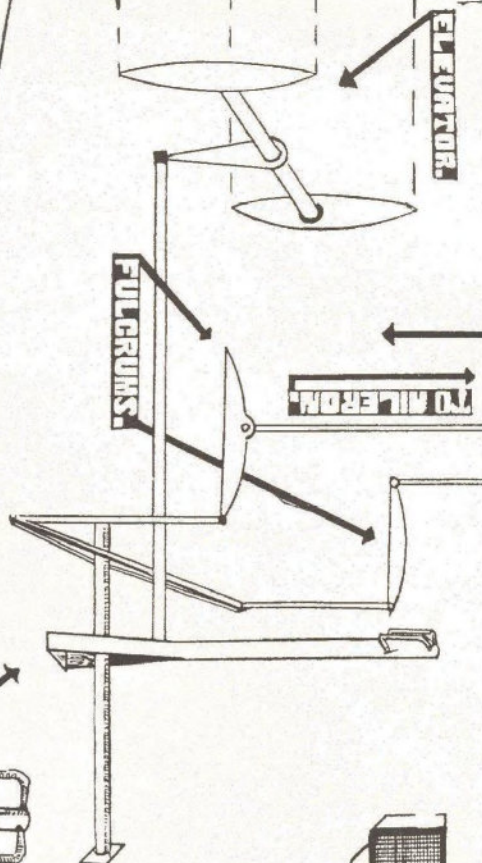

RADIATOR.

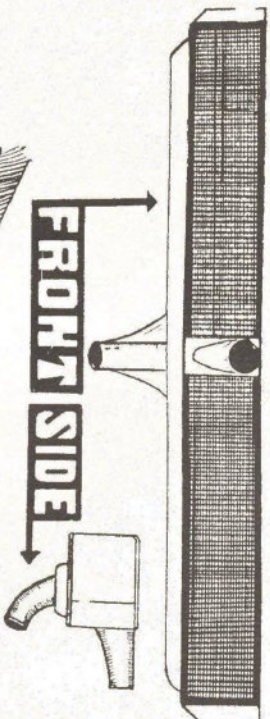

TAIL PLANE ATTACHMENT.

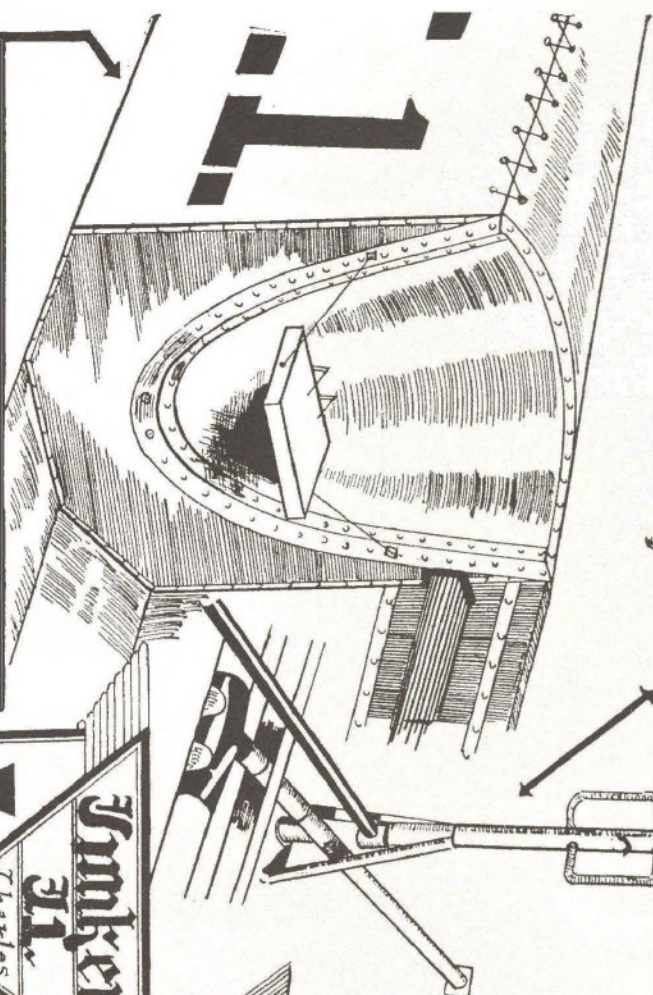
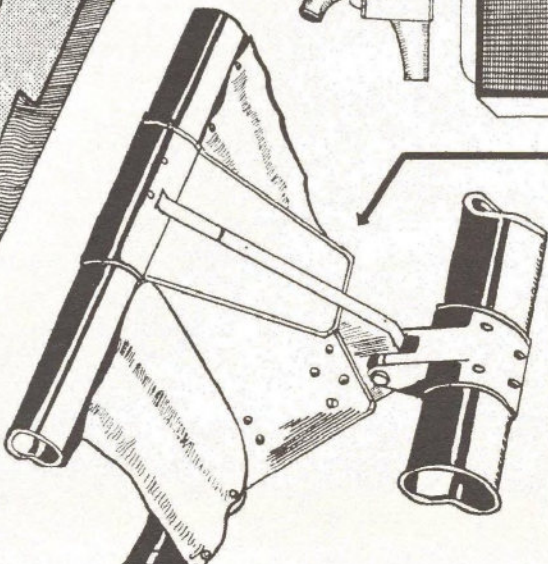

OBSERVERS SEAT.

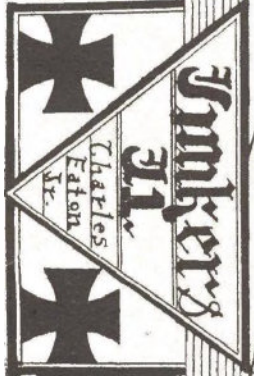

REAR VIEW SHOWING STRUT ARRANGEMENT.

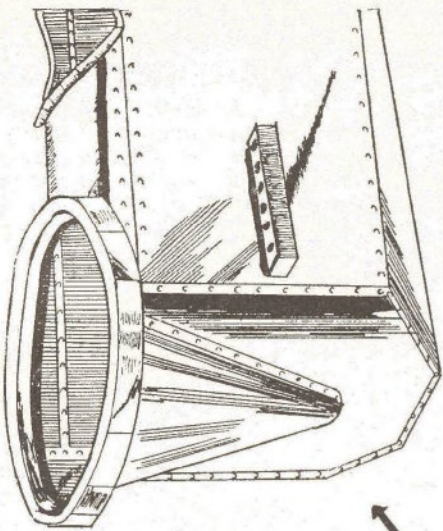

REAR COCKPIT.

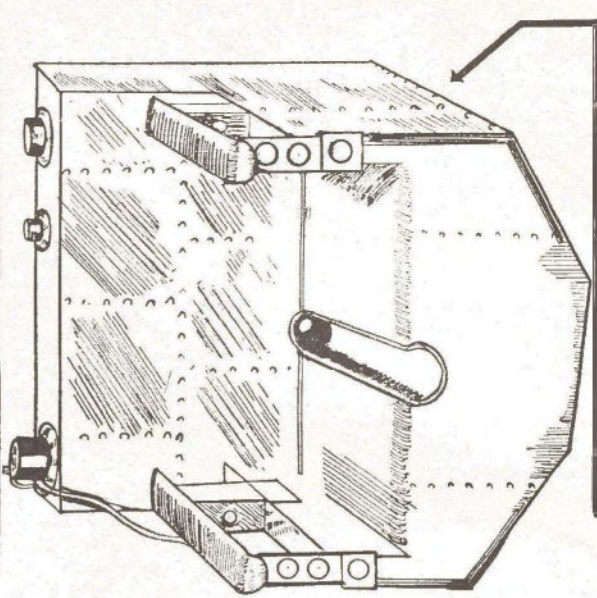

PILOT'S SEAT.

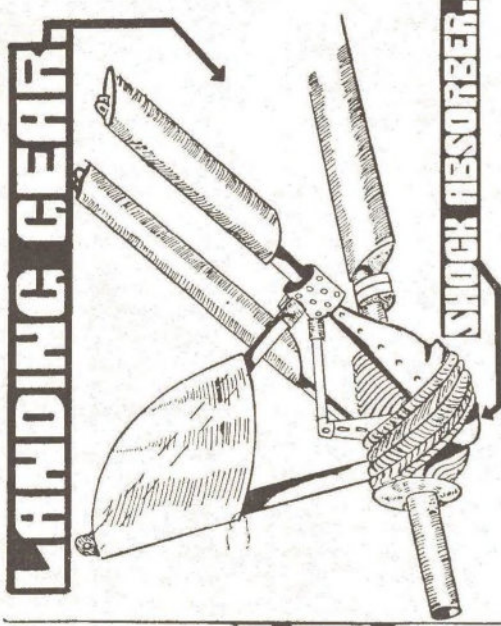

LANDING GEAR.

SHOCK ABSORBER.

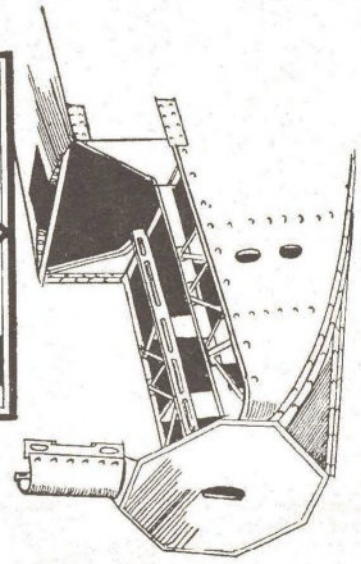
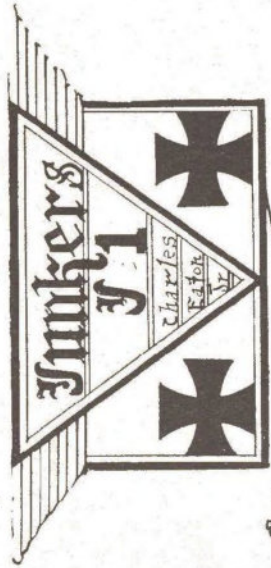

ENGINE MOUNTING.

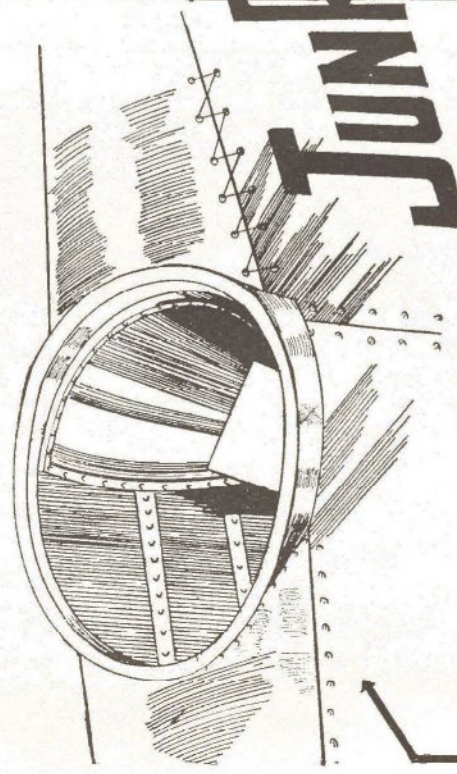

REAR COCKPIT.

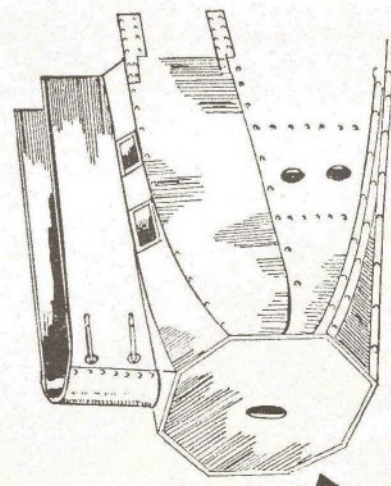

ENGINE HOUSING.

Sky-Power Facts *versus* Sky-Power Fancies

(Continued from page 9)

major engagement many miles outside of Kiel. Hitler has but one aircraft carrier, a vessel recently launched but not yet commissioned or fitted; and that is only a pathetic gesture at best. Naval experts who have seen the German carrier declare that it is badly turreted, too lightly built, and not capable of severe action conditions.

Germany might conceivably attempt a long-range bombing raid on New York City or some other eastern point. But it could not be considered seriously, because it would take many tons of bombs to make the attempt worth while. And here we wish to remind our readers that poison gas hasn't yet been discharged successfully from explosive bombs, so you needn't bother about a gas mask. Thus far, poison gas has only been successfully spewed through nozzles attached to portable tank containers. In this fashion, it must be discharged under the most favorable wind conditions—so until the Germans make an actual landing on our mainland and bring their tubed-up death vapor with them, we need not fear poison gas.

WHETHER we shall or shall not build 10,000 fighting planes to bolster our present air force is the question now battled in the newspapers. The main objection to the plan is based on the argument that once the last ships of the order are off the production line, the first batch built will be obsolete. By this it's meant that the initial craft will be a few m.p.h. slower than the most up-to-date jobs used by our hypothetical enemy.

Yet the writer holds that under emergency conditions, there is no such thing as an *obsolete* plane. Any ship that can take to the air carrying a pilot, a gun or a bomb, is a first-line weapon. The opposing force must figure that it has to be stopped somehow—or it will do

practically as much damage as one only recently completed.

We have been studying the figures concerning the world's fighting planes of 1933 as compared with those of 1938. Well, in the fighter class there is actually very little difference in top speed between the first-line equipment of 1933 and those built five years later in 1938. As a matter of fact, the Boeing P-26A of 1933 had a top speed of 235-m.p.h.—Whereas, the British Gloster Gladiator of 1938 does only 250. In 1933, the French Dewoitine did 231 top, whereas the highly famed German Messerschmitt—the standard job—is capable of only 310.

Sure, that extra 79 m.p.h. is something. But what we're driving at is the fact that a flock of those 1933 Dewoitines could still cause plenty of trouble in any man's war. So don't get the idea that 231 m.p.h. jobs might just as well be consigned to the ash heap. Besides, the anti-Hitler nations didn't stop building planes in '33. No, they have some swell 1938 models, too.

A like comparison in the observation and bomber types is equally as interesting. Let them dub the '33 craft of this category "obsolete" if they want to. Still, a few hundred of those models would be handy to have around if the guns again begin to boom.

It would be nice if we could plan our military plane output so that we'd have absolutely nothing but last week's first-line planes on the runways when war broke out—instead of last year's. But unfortunately we can't do that. Using the word "obsolete" in this fashion, practically every new plane run off the production line is "obsolete" by the time it is given over to some service pilot in a standard squadron.

It takes about five years from the time a new plane is first conceived by

the designer until it has reached a squadron and is ready for service flying. Then again, we must remember that most modern military ships are simply improved types, or derivatives of former models. We only have to look over the long line of Hawks, Hawkers, and Fiats to see this point. So just what is an obsolete plane?

Hundreds of "obsolete" planes were used in the World War—and they seemed to have done a darned good job. We have been told so many times by the arm chair critics that World War Germany put out much better planes than the Allies, who were always fighting with "obsolete" planes. Still, when we go back and look at the figures, somehow the Allies won the war in the air—and how! The Americans, in particular, did a good job with a lot of old Salmsons, Breguets, D.H.4's, Spads, and ancient-vintage Nieuports.

AS THIS is being written, the newspapers are still loaded with big feature articles stressing either the need, or the uselessness, of putting through a 10,000 plane order. Most of the writers are following newspaper policy, or, if they are service men, they are often stressing the requirements of their own particular branch of national defense. Yet, neither the Army nor the Navy spokesmen seem, as we go to press, to realize that *first and foremost the air services require men!* If they do realize it, why haven't they talked it up?

The finest pursuit in the world is a grounded, useless thing if there's no man in the cockpit. That man must be a trained airman, versed in the art of flight, skilled in the use of the plane in battle tactics, reasonably expert in the use of arms, and above all equipped with

(Continued on page 71)

LINED UP ON THE RUNWAY

for the

Next High-Revvin' FLYING ACES



FACT—Major Benard Law's thrill-filled, laugh-loaded, picture-packed account of how he pioneered an airline in revolution-racked Mexico. Lively anecdotes told exclusively for FLYING ACES readers.

Another up-to-the-minute aero article by David Martin, our ace sky writer.

And don't miss J. Lloyd Conrich's "Screwball Skymanship"—an ancient history rib-tickler on man's first attempts to fly.

FICTION—"Invisible Staffel," a brand new War-sky mystery featuring Philip Strange.

The latest corking adventure of the red-masked Griffon.

Plus "Spin Money"—Phineas Pinkham's newest 9th Pursuit mirthquake.

MODEL BUILDING—A great parasol flying model—the "Flying Aces Pronto".

Ray Heit's "Scrappy," a peppy 5-ft. cabin gas job.

Trail Blazer of the Air No. 13—the famed Army Douglas 1924 'round-the-world cruiser.

In May FLYING ACES

On Sale March 26th (Canada One Week Later)

Trip-Six Trap

(Continued from page 4)

Wide open, the Seversky drew alongside the diving airliner. Knight throttled to stay parallel, gazed tensely across the huge wing. By the glare of his landing-lights, he could see the cabin windows, those near the bow most clearly. At one of the windows, a face was pressed against the glass, and a creepy feeling went over Knight's scalp as he saw those stark white features. There was something awful . . .

The DC-3 pulled up with a crazy lurch, and Knight kicked away to avoid colliding. For a second the airliner seemed to hang there, on the point of stalling. Knight stared across at it, throttle closed to stay even. Then a cry of horror rose to his lips.

That stark white face had become a grinning skull!

CHAPTER II

DEATH-SHIP

STUNNED, Knight sat gripping the stick, the wobbling Seversky forgotten. The ghastly skull leered across at him a second longer, then the P-35 fighter, its speed lost, whirled off in the start of a spin. Knight brought it out 500 ft. lower, and as he gunned the motor a frightful scream rang in his ears. "We're doomed—Heaven help us—we're doomed!"

His eyes flicked up to the half-stalled DC-3. The airliner's nose suddenly whipped down, and with a mounting screech of its wings it plunged toward the edge of the city. Knight had a blurred glimpse of figures crumpled over the controls in the pilot's pit, then the huge ship was gone!

Then a dazzling flash of flame shot up from where it struck below, so bright that he had to rudder away to keep from being blinded. Seconds later, above the drone of his throttled motor, he heard the booming roar of the explosion. He banked away from the glare, then shielded his eyes and dived to within 200 ft. of the ground. The DC-3 had struck almost in the center of a huge aircraft plant, and the flames were spreading rapidly. Knight recognized the plant of the Flint Aircraft Company from its octagon-shaped field.

Two planes were hastily being removed away from the burning buildings, one under its own power. The other, a Flint fighter, caught fire as it was being shoved along a runway, and the mechanics ran to safety. The ship which had taxied clear was a Consolidated PB-2A two-seater and as Knight swooped past he thought he recognized the pilot. He banked again, glided in to a quick landing.

He was right—the man in the front cockpit was Larry Doyle. The Irishman jerked around as the Seversky slid alongside, then a look of astonishment came into his homely, battered face. Jumping out of the ship, he ran to the side of the P-35 just as Knight climbed down.

"Dick!" he shouted. "How in Hades

—where did you get that ship?"

"Stole it," Knight said. "And I may have to run for it any minute."

"You saw what happened?" Doyle said breathlessly.

"Yes—and more," Knight said in a grim voice. As swiftly as possible, he told Doyle of the starkly rigid face that had so suddenly turned into a skull. The Irishman stared at him open-mouthed.

"Then it happens before the ships crash!" he said blankly.

"What do you mean?" queried Knight.

"In both the other cases, the bodies were—" Doyle stopped, gripped Knight's arm. "There! That's what I mean—look close, by that second shop."

Knight peered toward the burning plant, and a shiver went down his spine in spite of the heat. Part of a human skeleton lay smoking on the ground, where the force of the explosion had catapulted it.

"It was reported just the same at Seattle and Chicago," Doyle said hoarsely. "The coroner at Chicago said it must be something that burns all the flesh off instantly."

Knight shook his head.

"What I saw happened before the explosion. And that makes it even harder to figure out. There wasn't any fire—not even a bit of smoke."

"Thank Heaven you got here," muttered Doyle. "They've shoved the job onto me—G-2's angle, anyway—and I'm stumped. That's why I sent that code. But I figured you'd use the Sikorsky; I had it all set for you to slip into Griffith's Park without anybody suspecting."

"That ship's too big—somebody would hear those four motors and start wondering," Knight gazed somberly at the blazing shop where the DC-3 had struck. "I just missed being in there. If they hadn't sold all the seats, it would have been the end of Dick Knight."

"Holy smoke!" said Doyle. "And here I was the one who—"

"Never mind," said Knight. "I didn't get on board. But I did steal one of the escort ships, so we'd better talk fast. I'll have to get away from here before I'm spotted."

A CROWD was already gathering along the side of the field, as the first fire companies arrived on the scene. Two squad cars followed the trucks, and police-lines were hurriedly formed. Knight looked past the burning Flint to where a little group of men stood watching the blaze.

"Who came here with you?" he asked Doyle.

"Nobody," said the Irishman. "I was intending to pick you up—that's why I brought a two-seater."

"How'd you come to be here, instead of at Griffith's Park?"

"Got a last-minute message from General Brett." Doyle stared at his former chief. "Judas Priest! You don't think it was a fake?"

"Looks like a scheme to finish you off," said Knight. "Whoever's engineering this must have known you were in charge of the investigation. This would have been a good way to get rid of you."

"Why, the dirty rats!" thundered Doyle. "If I ever get my mitts on those birds—"

"Then you have some idea who's back of it?" interrupted Knight.

"Not even a guess," Doyle said glumly. "But the C.A.A. says the motors of the ship at Chicago were wide open when it hit, so it wasn't a forced landing. There's crooked work somewhere, all right."

"What about that first 'Black Ghost' message?" cut in Knight.

"The first one?" Doyle said, startled. "You don't mean there's been another one? That this crash also—"

Knight pointed to the heart of the inferno.

"The pilot of Trip Six shouted the same thing—that the 'Black Ghost' got them just before the crash. And that's not all. There really was something up there—I saw a black blur, and something went past me so fast it almost threw my ship out of control."

"Don't tell me you've started believing in ghosts?" ejaculated Doyle.

"I've a hunch this ghost might prove pretty solid," said Knight. "I'd like another chance to meet him."

Doyle looked at the smoldering skeleton and gulped.

"Well, nobody ever said I was yellow. Let's go, then."

He started toward the two-seater, but Knight stopped him.

"Wait a minute. I want to see if I can find a bone or a skull that hasn't been burned. The explosion may have tossed part of those skeletons clear."

"You've a fine taste for nicknacks," grunted Doyle. "But I'll see what I can find. You'd better stay back here—I think my G-2 card will get me through the police-line."

Knight waited, leaving the Seversky's motor idling. In four minutes Doyle was back, gingerly holding a fragment of bone in his handkerchief. Knight started to examine it, but before he could take a good look Doyle gave an exclamation.

"Here comes a couple of ships, Dick! One of 'em looks like a P-35."

Knight wheeled. The first ship, a Seversky like the one he had stolen, moaned down across the field and landed near the other end of the burning plant. The second ship was a Fairchild, with *World Newsreel* painted on its side, and camera-guns fixed on both wings. It braked to a halt not far from the Consolidated, and a man climbed out with a news photographer's Graflex, leaving another man at the controls.

"Turn your face away, Dick," Doyle said hastily. "G-2 is just aching for a clear picture of you."

"Don't worry, he's after fire pictures," replied Knight. "But at that, we'd better take off before that Army pilot—"

"What's the matter?" demanded Doyle, as Knight left the sentence unfinished.

"Get around behind this ship," Knight said swiftly. He ducked back of the P-35, waited until Doyle had joined him. "Did you recognize *him*?"

"Huh?" said Doyle. He peeped around the tail of the fighter. The man with the camera was gazing intently at the fire, his hatchet profile etched sharply against the flames. Doyle gave a violent start.

"Wiegand, the Austrian jewel smuggler, or I'm a Hottentot!"

"It's Wiegand, all right," said Knight. "But there's no jewel angle to this business. I always thought there was something behind that smuggling racket."

"What do you suppose is the idea of the newshawk act?"

"What's more important, who is he serving?" Knight said tersely. "Doyle, we've got to nail old Hatchet-Face and have a little talk."

"But how?" He'll put up a squawk. Those cops will be sticking their noses into things—and you know what that means."

"We'll have to risk it. Start your motor again—I'll try to shanghai him into your ship. A little tap on the head will keep him quiet until you reach Griffith's Park. I'll follow with the P-35."

THE MAN in the Fairchild was leaning out, watching the fire, on which Wiegand had trained his camera. Knight stole around the tail of the Seversky, his hand on the gun under his coat. Neither Wiegand nor his assistant saw him, but with a sudden uneasiness he glimpsed the other P-35 taxiing toward the three ships. There was no time left for a careful approach. Jerking out his gun, Knight ran toward the Austrian. The man in the Fairchild let out a yell, half-muffled as Doyle's motor revved up. Wiegand spun around, and consternation came into his hawklike face when he saw the gun.

"Over to that Consolidated!" Knight snapped.

Wiegand's greenish eyes leaped up to the secret agent's face.

"Knight!" he gasped. *Zum Teufel!* They told me—"

"That I was a traitor?" Knight graded. "Well, it happens that this traitor is still working for Uncle Sam. Get moving!"

Wiegand cast a desperate glance toward the Fairchild. His accomplice had jumped out on the wing, gun in hand, but Knight's swift maneuver had already put Wiegand between him and the ship.

"Tell your friend to stay put—if you want to keep healthy," Knight clipped out.

Wiegand groaned.

"Don't shoot, Guiglio! This devil will kill me."

Guiglio dived back inside the ship, and the Fairchild's motor roared. The camera-ship pivoted, one wheel locked. But before it could complete the turn the taxiing P-35 cut in front of it. Knight was stepping backward toward the Consolidated, with Wiegand following at gun-point. But as soon as the

Fairchild was blocked he whirled the Austrian around toward the two-seater. Doyle jumped from the pilot's pit, pistol reversed, but Wiegand threw himself sidewise with a frantic shout before the Irishman could stun him.

"Help! It is the traitor—Knight!"

The Army pilot had swung out of his ship and was half-way toward the Fairchild. At Wiegand's cry, he jerked around and his right hand darted for the .45 at his hip. Knight hurled the Austrian to the ground, plunged under the two-seater's wing. A slug from the .45 tore through the left wingtip, and another bullet whistled past his head. He sprang away from the ship, so as not to bring Doyle in range with the Army pilot's gun. But the third shot never came. For Wiegand, leaping to his feet, had vaulted into the cockpit of the stolen P-35, and the Army man, with a sudden shout at recognizing the ship, was dashing after him.

Five or six policemen were sprinting toward the ships, Wiegand's accomplice kicked the Fairchild around, and from the supposedly harmless camera-guns two streaks of flame belched at the running officers. Three of them fell, mortally wounded. Knight triggered two quick shots at the killer, but the Fairchild whipped into the wind and roared down the runway, with Wiegand's ship close behind.

Knight whirled to Doyle, lifting his .38 so that the P-35 pilot and the policemen would see it plainly.

"Drop your gun!" he snarled. "Now, get into that ship!"

The amazed Irishman let his pistol fall, and scrambled into the rear cockpit. Knight threw himself into the front seat, with police bullets zipping perilously close to his head. Opening up the motor, he sent the two-seater racing after Wiegand's ship.

"Are you crazy?" Doyle howled through the interphone. "Why'd you pull that gun on me?"

"How would you explain it later?" Knight retorted. "Three men would be



ready to swear you helped me escape. This way, you've a perfect alibi."

"I could cover it somehow," said Doyle. "Now you've given the fools another case against you."

"One extra point won't make much difference," responded Knight. "Look out! Wiegand's coming back!"

The Austrian had shot into a zoom and whipped back in a 180-degree turn. Now, guns blazing, he pitched down at the speeding Consolidated. Knight lifted the two-seater ten feet from the ground, held the nose flat until Wiegand's tracers were within yards of the screeching wings. Down went the right rudder pedal, and with a violent skid the ship was out of the Seversky's range. Before Wiegand could twist around,

Knight sent the PB-2A up in a furious chandelle.

The Fairchild charged in, its masked machine-guns pounding fiercely. Knight pressed the stick-button, and his cowl Brownings spat out two fiery blasts. Guiglio dived frantically. Knight hurled another fusillade after the false camera-ship, rolled back to fling a burst at Wiegand. His thumb was on the trip-button before he saw there were now two Severskys in the air.

"Hold it!" Doyle bawled through the interphone. "That's the wrong ship!"

A SPLIT-SECOND BURST had already ripped from Knight's guns. He booted the rudder, and the PB-2A swerved away. A hail of cupro-nickel slugs pounded the two-seater's wing as Wiegand took advantage of the turn. Doyle unlimbered the rear guns, sent a long burst across the cowl of the Austrian's ship. Wiegand pulled clear with a snap-roll, and went streaking off into the northeast. Knight raced after him, climbing to get above the fighter and keep it in sight against the city's lights.

"Somebody must've hit the other Seversky's engine," Doyle said through the phones. "It's making a forced landing back at the field."

"Where's the Fairchild?" said Knight, not taking his eyes from Wiegand's ship.

"Can't see it," reported Doyle. "Guess you scared out our friend Guiglio."

"Something odd about that," muttered Knight. "Guiglio's an Italian name—and he looked Italian, too. Wiegand was an outlaw from his own country before Hitler took it over—and that might mean he was secretly a Nazi. Maybe there's something to that rumor of their agents working together."

"Where do you suppose Wiegand's heading for now?" said Doyle.

"I don't know. But we've got to keep him in sight if possible. "It's almost a sure bet that he knows what happened to those airliners."

"It's a crazy mess," growled the Irishman. "Even if we nail Wiegand, we can't prove anything on him."

"We'll risk that," Knight retorted. "The main thing is to keep from losing him."

The P-35 was clearly outlined against the glow, and Knight had no difficulty in keeping it in sight until it was beyond Pasadena. By this time Wiegand had climbed to pass the San Gabriel Mountains, and by holding his own altitude Knight was able to ease in close enough to see the Seversky's exhaust flames.

Twice, Wiegand changed direction, evidently to make sure he was not followed, but each time he came back to his first course. Knight kept as close as he dared, and at the end of half an hour he was elated to see the fighter nose down.

"Where are we?" Doyle asked eagerly.

"Somewhere over the Mohave Desert," Knight said through the interphone. "It looks as though—"

T-t-t-t-t-t-t-t-t! Without the slightest warning, a row of bullet-holes appeared in the top of the Plexiglass enclosure. Knight swiftly rolled to the left.

"Get him, Doyle!" he shouted as he came out.

"But there's nobody on our tail!" roared the Irishman.

Knight threw a tense look backward. Not the flicker of an exhaust, not even a single tracer showed in the darkness behind them.

But a hail of bullets was pounding into the two-seater's tail!

CHAPTER III

SPY-DEVILS' DEN

WITH a muttered oath, Knight jammed the stick forward and threw the Consolidated onto its back as though for an outside loop. As the ship went over he snapped into a tight roll. The two-seater yawed in a violent current of air, and for the second time that night the fugitive agent felt, rather than saw, some strange thing rush past in the gloom. Banking swiftly, he flashed on the landing-lights. A dark blur flitted up from the two bright tunnels, and before he could zoom after it, Wiegand's P-35 came plunging in from the side.

Doyle hammered a savage burst at the Austrian, and Wiegand shot underneath to avoid the glare of the lights. Knight backsticked, feverishly searched the sky for a sign of the eerie ebon blur. Another burst from the invisible guns gouged at the left wingtip and Knight swore through set teeth. He whipped around with his thumb on the stick-button, suddenly glimpsed a coal-black wing in the edge of one landing-light beam.

"So that's it!" he rasped. His thumb went hard on the button, and the Brownings cut loose with a snarl. The black wing whirled out of the beam, and was gone. Knight hauled the two-seater into a zoom, swerved into an Immelmann. There was no sign of the mystery ship, but the turn threw Wiegand's fighter in line with his guns.

The Austrian banked madly as Knight's tracers ripped into his wings, and at the same moment Doyle gave a wild yell.

"Look out, Dick! It's the Black Ghost ship!"

Knight corkscrewed into a fast chandelle, with tracerless bullets crashing across his cowl. Doyle's guns blasted and the bullet-barrage abruptly ceased. Knight whirled in his seat, stiffened as he saw Doyle's target.

From the cockpit of a black Hawker Hurricane, a weird hooded figure was glaring down at the two-seater. The hood, like the ship, was a dull black that gave off no reflection of light, save for two narrow slits for the pilot's eyes. There were no distinguishing marks on the ship. And the protruding tips of the guns were a coalblack to deflect light rays.

Even with the glare of the landing-lights almost directly upon it, the black Hawker still looked like a phantom ship. Knight tripped the Brownings, rolling the Consolidated into a vertical turn. The Black Ghost kicked inside the turn, sideslipped out of Doyle's fire and disappeared in the darkness.

Wiegand's guns were now spurting again, and Knight climbed steeply to

keep from being boxed between the two ships. The Austrian stopped firing, darted away in the shadows. Knight switched off his lights, hoping to spot Wiegand's exhaust flames. But almost at once a vicious fusillade hammered the two-seater's wings.

The burst seemed to be coming from above and to the left. Knight clipped a warning to Doyle through the interphone, hurled the Consolidated into a tight climbing turn, at the same moment snapping the lights on again.

"There he is—he's trying to dive past!" shouted Doyle.

Knight nosed down, plunging after the mysterious Hawker. His guns were ranged on the black ship's tail when Wiegand came charging in to the unknown pilot's aid. The already bullet-torn enclosure flew to pieces over Knight's head.

"Take that cut-throat!" he yelled back at Doyle.

"Can't—I've got a jam!" bawled the Irishman.

Knight braced himself, hauled the PB-2A out of the dive and around at the plummeting fighter. One furious burst leaped from his guns, straight for the nose of Wiegand's ship. Smoke gushed out from the Seversky's cowl and hid the Austrian from view. Knight ruderdered clear, hastily searching the gloom for a trace of the Black Ghost. Flames suddenly forked back through the smoke that hid Wiegand's cockpit.

The Seversky went into a flat skid, and out of the oily smoke the Austrian's tumbling figure appeared. White silk bloomed out, as Wiegand opened the seat-pack chute which Knight had left in the ship. The blazing fighter whirled threatening close to the spreading silk. But Knight had no time to see what happened, for the Black Ghost streaked down to stitch vengeful lead across the two seater's fuselage.

Knight started an Immelmann, rammed the stick forward as Doyle gave a shout.

"Hold her straight, Dick! I've cleared the jam!"

The muffled pound of the rear-pit guns rose above the scream of the wings. But Doyle's defense came too late. The motor's thunder abruptly ended as the Black Ghost's final burst clipped the distributor head. Knight grimly nosed down, zigzagging to evade any further bullets. The Black Ghost held his fire, circling well out of the glare from the falling Seversky.

"Sorry, Dick!" groaned Doyle. "Another second and I'd have had him."

"It's all right, old man," said Knight. "We're not licked yet. I think our hooded friend is trying to capture us alive—and we may be able to fox him."

HE had cut off both the switch and main fuel-valve, and the ship was howling down in a steep dive. By the light of the flamer, two parallel mountain ranges were visible, a long, narrow valley between them. Wiegand's chute was oscillating down at one side. Knight watched the burning Seversky crash on the slope of the nearest range. It blazed up brightly, and a huge plume of smoke gave him the wind direction.

"Where's the Black Ghost?" he flung back at Doyle.

"Circling over us. Just out of range—the yellow rat!"

"See that level spot across the valley? I'm going to land there. Be ready for Mr. Ghost if he makes any sudden dive for us."

"I'll blow him right out of his hood!" returned Doyle.

Knight lowered the landing-gear, swung into the wind. Wiegand was drifting down a quarter of a mile away, and Knight saw him twist around in his harness and stare across at them. The Austrian flicked a glance toward the ground, then waved both arms in a signal to the Black Ghost.

The hooded pilot nosed down, diving well out of range until he was below the PB-2A. With a sharp chandelle, he charged upward at the two-seater. Knight dropped the left wing in a vertical slip, throwing the Hawker in line with Doyle's guns. The Irishman cut loose with a fiery blast, and the Black Ghost hurriedly pulled up into the gloom.

The maneuver took the PB-2A to within 500 ft. of the ground. Knight ruderdered out, leveled off, then fishtailed to kill the ship's forward speed. The two-seater was almost at the stalling point when he suddenly realized there was something peculiar about the ground. It was *too flat*, too artificial looking . . .

"Brace yourself!" he suddenly shouted back at Doyle. "We're going to crack up!"

With a ripping sound, the two-seater hit—and broke through a tight-stretched canvas which hid the ground. Knight had a fleeting glimpse of a huge plane, of cars and trailers, and of men running in all directions. Then the Consolidated struck on one wingtip and groundlooped to a jolting stop at the edge of a deep gully.

The impact threw him against the side of the cockpit, and when his briefly-dazed senses returned the ship was surrounded by a dozen armed men. One of them stepped onto the crumpled wing, shoved a pistol against Knight's head.

"Climb out," he ordered harshly. "No tricks, or I shoot."

His voice had a guttural, Teutonic note that stamped him as a German. Knight looked at the rest of the men as he staggered out of the wrecked ship. Behind the German were two men who looked like Italians, and on the edge of the group, back in the shadow, he saw a face distinctly Oriental. The two-seater had crashed at one side of a cleared area hidden by canvas tarpaulins erected on poles and fastened together to form a rectangular surface about the size of a hangar floor. It was this crudely-painted canvas which had given him a warning, too late for him to turn.

A DC-3 bearing the Coastal Airlines emblem stood in position for taking off down the valley. Several rigid, staring faces were visible at the windows. The cars and trailers were drawn up close together, so that they would be hidden under the canvas, and a big fuel truck stood not far from the airliner. Knight could also see a small floodlight unit intended for illuminating the landing-

space beyond the concealed area, but it was not switched on. The scene was lit by the glow of the burning Seversky.

"What will we do with them?" one of the group demanded of the German. "Get rid of them like the others?"

"Let Herr Wiegand decide that," said the German, gruffly. "He may want to question them first."

"If I know Herr Wiegand," muttered another man, "he will make short work of them, after their shooting his ship from under him."

"Too bad we didn't get him with it!" flamed Doyle.

FOR ANSWER, the other man struck the ex-Marine savagely across the mouth. Then as two men dragged him back, the German jabbed his gun against Knight's ribs as the fugitive agent started to leap to Doyle's aid.

"Here comes Nasaki," exclaimed one of the Italians.

The coal-black Hawker then made a swift landing and rolled up to the covered space. The pilot taxied just inside, switched off his motor, and jumped out. His slight-built figure was clad entirely in black, and as he strode forward into the group he looked like some sinister being escaped from the Pit. With a furious jerk, he tore off his hood, revealing the brown face of a Japanese.

"Kochi! Stand aside!" he snarled. "I will deal with these two *Amerika-jin!*"

"Not so fast, Nasaki!" a grating voice broke in. It was Wiegand, who had approached from one side unnoticed while attention was focussed on the arrival of the Hawker. His clothes were torn, and an ugly bruise on his face testified to a none-too-gentle landing.

Nasaki turned fiercely at Wiegand's interruption.

"It was understood there were to be no prisoners left alive."

"I'll take care of them, don't worry," snapped Wiegand. "But it so happens these are no ordinary prisoners. This ugly gorilla with the broken nose is the Irishman, Doyle. And the tall one is none other than Richard Knight, the Q-Agent who was supposed to be a fugitive."

Nasaki's slanting eyes blazed.

"Then we have been tricked! Knight has been working against us all this time!"

"I don't know," Wiegand muttered. "But I intend to find that out—and some other things."

An unholy look came into Nasaki's face.

"Give him to me—we Japanese have ways of making men talk."

"I am not entirely helpless at that game, myself," returned Wiegand curtly. "But first, we had better make sure we are safe. Did you see any other planes?"

"Only the two-seater," said the Niponese. "I shot down the two Army pilots who were escorting the plane from San Diego, as you probably know. There was a third Seversky which did not seem to be with them—I saw it just as I was setting the air-track for the Douglas to strike the factory. But there was no time to bring it down."

"That must have been the plane in

which Knight landed at the Flint field," said Wiegand. "Doyle came there alone in the Consolidated PB-2A; our last information before we set the trap for him was that he had no passenger, but was flying to Los Angeles. He was undoubtedly going to meet Knight somewhere else, and our false order brought them both to the Flint field."

"If you had been more careful, they could not have followed you from there," Nasaki said sharply.

"I thought at first that Doyle had been killed," growled the Austrian. "He and Knight were hidden behind the Consolidated when Guiglio and I landed in the Fairchild to photograph the effect of the new explosive."

"But where is Guiglio now?" broke in one of the Italians.

"Probably on his way here," replied Wiegand. "He escaped after a battle with these two."

"Then the Flint plant was destroyed, as planned?" said the German who had temporarily been in charge.

"Completely," said Wiegand. "But after we finish with the Douglas plant tonight, we will shift operations to the



Atlantic coast while their investigators are busy here in California. It would be fatal to push our luck too far in this territory."

"You've already pushed it too far, Wiegand," Knight said grimly. "Some smart inspector will guess the truth when they start checking the passenger-lists of those three ships and find all those faked names."

"Very clever," sneered Wiegand. "But even the brilliant Mr. Knight did not guess until he landed here. If you were going to live long enough to pay, I would make a wager with you that they will not know the truth for months, if ever. And long before that time we will have destroyed your principal aircraft factories and wrecked America's plan for a superior air force."

"You're mad," said Knight. "One slip—and it will mean war."

WIEGAND laughed sardonically. "No one can prove any specific nation is back of us. That has been carefully covered. And your stupid Intelligence will never catch us, anyway."

He turned to the German.

"Schunt, have you changed the number on the old DC-3, as instructed?"

"The ship is ready," replied Schunt. He bared his teeth in an ugly grin. "And the passengers are waiting for their little joy ride."

Wiegand scowled. "I'm in no mood for jests. And speaking of passengers, there will be only one passenger besides the crew of the Coastal airliner which our men will seize after it takes off from Oakland tonight. We were able to get all the seats except one which had been reserved for several days."

"But what if the Coastal company

should cancel that trip?" put in Nasaki.

"The airline companies always keep going after a crash," responded Wiegand. "Otherwise, it would focus too much attention on the disaster. Have no fear, their next plane will leave as scheduled; then our men will take it over and fly it here for our later use—and this Douglas will substitute for it and fly the rest of the route. That is, with a slight deviation at the end."

Nasaki motioned toward the airliner. "Perhaps we had better exchange details, Herr Wiegand. You are probably not in the mood for another parachute jump, after this last one."

"We'll go through with it as planned," grated the Austrian. "You'll fly the Hawker again. But this time be ready to take over radio control sooner. I'll jump as soon as I get the ship up to 5,000 ft. and on its approximate course. One of the cars can follow to the highway and I'll drop as near to it as possible. After you crash the DC-3 into the Douglas plant, come back here and re-fuel. Then we'll head for our Eastern base and meet the Trip-Six ship our men seized."

Wiegand now stopped short, and a tense silence fell over the assembled men as the drone of a motor sounded from somewhere up in the night.

"It's probably Guiglio," muttered the Austrian. "But we will take no chances. Schunt, take three men and stand by the machine-guns. Don't turn on the flood-light unless this newcomer repeats our signal."

The four men hurried to the edge of the covered area. Knight shot a side glance at Doyle, and he thought the Irishman nodded surreptitiously, though he could barely see him in the shadows.

The drone of the approaching ship grew louder, Knight waited tautly, saw Nasaki, then Wiegand stare up through the hole the Consolidated had torn in the canvas. There was an instant when from the corner of his eye he saw one of his guards also gaze up into the darkness. With a sudden lunge, he sent the man sprawling and snatched up his gun!

"Run for it, Doyle!" he shouted.

A pistol blazed close to his head, and he saw the face of his other guard. He fired pointblank, dropped the man with a bullet through his brain. A chorus of oaths and yells filled the air, and he heard Doyle's voice rise fiercely above the rest. Then leaping over the fallen guard, he raced toward the black Hawker.

CHAPTER IV

SKELETON MASQUERADE

A DARK FIGURE sprang into his path, and he heard a shrill cry in Japanese. He jabbed a stiff left to Nasaki's jaw, and with a howl the Niponese plunged to the ground. Dodging around a trailer, Knight ran toward the spot where he thought the Hawker stood. Just in time, he saw the darkness of the gully and jumped back.

A flashlight stabbed the gloom, caught him with the edge of the beam. Above the clamor he heard Wiegand's triumphant yell. A gun crashed, and the

slug ripped through his left sleeve, searing his arm like the flick of a branding-iron. It was only a crease, but it jerked him around, and he stumbled and fell before he could catch himself.

"You damned butcher!" he heard Doyle cry. Then the flashlight went out. He got to his feet, started blindly along the edge of the gully. He had gone about twenty-five yards when he saw an improvised gangway to the cabin door of the DC-3. At the same moment another light went on back near the Hawker.

He could see nothing of Doyle, and realizing that he might be recaptured at any instant he ran up the steps into the airliner's cabin. If he could by luck find a machine-gun in the big ship, he might be able to turn the tables.

Keeping back from the door to avoid any sudden rays from the flashlight, he made a hasty inspection. Midway of the cabin, several seats had been removed, leaving space for a crude bomb-bay. Apparently, this ship had been in the hands of the spies for some time and had been originally altered for dropping bombs directly from the cabin until Wiegand had hit on the scheme for crashing entire ships with their deadly cargoes. A cable from a trap in the floor ran forward toward the pilot's cockpit, but that it was not now intended for use was evident from the safety-wiring with which the release-gear was secured.

Several figures sat stiffly in seats on both sides of the cabin. The nearest one had its head turned so that its face rested against the glass. Knight stared, then he saw that the face was a cheap mask such as might be seen on the streets at Halloween. The figure had a queer, unnatural pose—and as he started hurriedly through the ship he saw the answer.

The figures were skeletons, masked and with the upper parts dressed so as to appear like passengers sitting at the windows!

One of the skeletons had slipped a trifle, so that the hat and mask wired to the skull were awry. Knight realized then that he had found the answer to that weird transformation he had observed above Los Angeles. The jolting of the radio-guided airliner had knocked the mask from one of the skeletons in the moment when his attention had been diverted.

HIS SWIFT SEARCH of both cabin and cockpit failed to produce a machine-gun, though he glimpsed the radio-gyro pilot by which Wiegand intended to send this ship to a crashing end. Then he was halfway back to the door when the floodlight unit went on and lit up the landing area.

Knight dropped behind a seat, took a cautious look through the window. The false camera-ship was leveling off; obviously Guiglio had given the correct signal during the hubbub over their escape.

But Knight's heart sank as he saw Doyle. The Irishman had been caught and was standing, hands tied behind his back, in front of Wiegand and Nasaki. The two men seemed to be arguing, but Knight could not hear their words. In a minute, Guiglio joined them, and then

to the Q-Agent's consternation the entire group of spies started toward the airliner, two men marching Doyle between them.

He turned, shot a desperate look around the ship. The next instant he had dragged the nearest skeleton from its seat and was racing to the stewardess' pantry. He tore the hat, coat, and mask from the bony figure, whipped off his own hat and coat and ran back to the seat. If they happened to look in the pantry, he was finished. But this was the only way out.

In a twinkling, he made the change. Mask in place, his gun hidden on the cushion, under his right leg, he waited almost without breathing. Wiegand's was the first voice he heard.

"—too late for the excitement, Guiglio. I had to kill Knight. Too bad—for we might have learned something from him."

"If he did not roll too far down the gully, we can find his body and search it," volunteered Schunt. "He might have had some valuable papers with him, if he was such an important agent."

"I doubt it. But you can search for his carcass after Nasaki and I take off," Wiegand said curtly.

"But why are you bringing this ugly prisoner in here?" Knight heard the Japanese say angrily.

"I'm going to give him a pleasant little ride—into Eternity," Wiegand said harshly. "I've a double score to equal now, after that beating he just gave me. He'll have time to regret he ever saw me—before he's blown to bits!"

Knight's blood turned cold. Rigid as the other grim figures in the seats, he watched through his mask-slits and saw Doyle tightly bound beside one of the skeletons.

"A cheerful little companion for you," mocked Wiegand. "Unfortunately, it



cannot speak—but doubtless you would rather be left to your own thoughts in this last hour."

"Herr Wiegand," Schunt said nervously, "it is getting close to the time."

"I am aware of that," snapped the Austrian. "Start the motors and set the radio-pilot for the wave-length of the transmitter in the Hawker. Nasaki, you had better take off at once. Circle at 5,000 and wait for my signal."

The Japanese scowlingly left the cabin, followed by all but Wiegand, Schunt, and the Italian, Guiglio. While Schunt went forward to start the motors, the two spies lifted a curved plate at one side of the bomb-bay.

"Dios!" exclaimed Guiglio. "I would not fly with that load for all the money in the world!"

Wiegand shrugged. "It is safe enough, until I set the switch before I jump. Even after that, it will not detonate until the ship crashes—and by then

only this meddling American will be left on board to worry."

One of the motors sputtered into life, and soon both of them were roaring smoothly. Knight slid his right hand toward the butt of his gun, but Schunt came back into the cabin before he could move, and he saw a pistol at the German's hip.

"The radio-pilot is set, and everything ready," Schunt reported. "Good luck. I will have the car near the junction of the highway and the south road."

"I shall be there in twenty minutes," promised Wiegand. He strode forward, and Schunt and Guiglio quickly left the cabin. Knight drew a long breath as he heard the door close. He still dared not move from his seat, for the floodlight was bathing the windows, and one of the spies might warn Wiegand before he could take off.

THE MOTORS revved up, idled, and then the big ship slowly taxied from under the canvas. Through the window, Knight could see dust settling from the Hawker's take-off. It seemed an hour before the engines opened up and the big Douglas began to roll. The moment the tail was up he darted down the aisle to where Doyle was bound. The Irishman was struggling futilely to free himself. His head jerked around as Knight stopped beside him, and a stunned look came into his eyes as the secret agent pushed up the mask.

"Dick!" he cried hoarsely. "How in the name of—"

"Not so loud!" Knight cautioned him. He laid the pistol on the seat, tugged at the knots. "Thanks to you, I got clear of the gully—Wiegand barely nicked me."

"Thank the Lord!" whispered Doyle. "I thought you were a goner!"

The ropes fell away from his arms. Knight cast a look forward, feverishly bent over the knot at Doyle's ankles. It proved stubborn, and half a minute passed before he could loosen it. The DC-3 was now climbing steeply, the cabin shrouded in gloom, except for the faint glow that came back from the cockpit. The ropes were just slipping from Doyle's ankles when he clutched tensely at Knight's shoulder.

"Look out, Dick! He's coming aft!"

Knight barely had time to spring into the adjoining seat and slip his mask into place. Gun in hand, he waited while the cockpit door opened and Wiegand hurried back to the bomb-bay, lighting his way with a flashlight. The airliner continued to climb, on the gyro-pilot.

The Austrian reached down to set the detonator switch, and Knight saw that he had already buckled on his parachute harness. He had no weapon in sight.

Knight gripped his pistol. But before he could even move, something seemed to warn Wiegand. He straightened up with a jerk, one hand flashing under his coat. Knight leaped, and a horrified look came into the Austrian's hatchet-like face as the supposed skeleton suddenly came to life.

With a vicious smack, Knight's fist connected under the other man's ear. Wiegand tottered back, then his knees sagged and he fell in a twisted heap.

Knight tore open his coat, took out a small, venomous-looking Mannlicher pistol. He handed the gun to Doyle.

"Why didn't you shoot him?" Doyle said bluntly. "He'd have killed you in another second."

"I want him—for proof of this spy-scheme," Knight clipped. "Keep an eye on him—I'm going to flash a warning to Oakland—for Coastal to hold up that passenger plane."

He ran to the cockpit, hastily set the transmitter. The Douglas was droning through solid blackness, with not a light below nor even a star above.

"Emergency! Calling Oakland . . . Emergency, from G-2, War Department, to Oakland!" he shouted into the mike.

Almost at once, Oakland came through, the dispatcher's voice edged with tension:

"Oakland to G-2. Go ahead!"

"Hold your next plane, Coastal!" Knight said swiftly. "Arrest all passengers. All but one are spies, planning to seize the ship! They are the same spies who were back of the three mystery crashes. Send fighters to Mohave Desert, course from Los Angeles—"

A bright flash abruptly lit the sky, cut Knight's words short. He spun around, went rigid in the seat. The Black Ghost ship was hurtling down the sky under a parachute flare. Nasaki had been tuned in—had caught his desperate message!

KNIGHT RAMMED the throttles wide open, threw the DC-3 into a vertical bank. From behind him came a sudden yell, then Doyle's voice sounded above the roar of the motors.

"Dick! Stop him—in Heaven's name!"

Knight flung a taut look backward. Crouched behind the bomb-bay, out of

gunshot, Wiegand was clawing at the detonator control, his face distorted with a maniacal fury.

Doyle lay at the end of the cabin, where the sudden turn had thrown him. As he tried to pull himself up, Wiegand's hand shot to the switch-box.

"Keep back, damn you!" he screeched. "Or I'll blow us all to hell!"

A hail of bullets from the Hawker's guns came pounding through the top of the cabin. Knight stood on the rudder pedals, and the crashing torrent went smoking through one side, missing the bomb-bay by inches.

"Nasaki, you fiend!" screamed Wiegand. "Keep away—I've got them stopped!"

The black ship whirled by, shot up in a furious climb. Knight groaned as he saw it twist around at the top. One bullet through that huge bomb . . .

He jerked around in his seat. Wiegand was on his knees, one hand inside the switch-box. Knight let go the wheel, seized the emergency lever which ran to the bomb-bay. With a prayer on his lips, he raised the gun and aimed at the safety-wiring which kept the release from moving.

Wiegand's head twitched around, and a wild glare came into his eyes when he saw the lifted gun. Fire jetted from the pistol's snout—and with a sudden grinding the bomb-bay trap split open. Wiegand gave a frightful shriek and plunged through the trap beside the falling projectile.

THE BLACK GHOST SHIP was now almost upon the airliner, its masked guns pounding the nose. Knight snatched at the wheel, hauled it hard back. The Douglas howled up into a steep zoom, and Nasaki shot past, guns

hammering. Knight had a blurred glimpse of the hurtling fighter, and the weird hooded figure at the stick.

Then a terrific concussion shook the sky, and the Douglas trembled under a rain of fragments that flew through the blazing heavens. Knight brought the ship into level flight, stared dazedly through the cockpit window.

A huge cloud of bright-colored smoke was spreading across the sky.

But the Black Ghost was gone!

A feeling of awe crept over him as he realized what had happened. Either Nasaki's bullets had struck the bomb, or Wiegand's last desperate movement had released the detonator.

Doyle came forward, climbed into the cockpit. Neither man spoke for a minute, then Knight reached across and handed the transmitter mike to the Irishman.

"Better call G-2 and explain that call. Tell them to be on the lookout for the real Trip Six ship—and where to spread a dragnet for those rats down below."

Doyle made the call. Then when he had finished he glanced across at Knight. The fugitive agent was gazing down at the desert, still lit by the slowly descending bright cloud. There was a crossroads almost directly ahead. A strange smile touched Knight's lips as he saw it.

"That must be the place—remember what Wiegand said. I'll be there in twenty minutes."

Doyle looked over the side. The bright cloud slowly touched the ground, spread out and began to fade. He stared back at Knight, and the secret agent slowly nodded.

"Fate's a queer thing, Doyle. *Herr* Wiegand has kept his appointment, after all."

The Clue of the Breda Brood

(Continued from page 20)

Kirk let out a sigh, drew a deep breath, and asked: "What the devil happened?"

One of the men came over and rammed Kirk's chin high with a heavy thumb and forefinger. "That's what we want to know. What's the bloody game?"

Disregarding the R.A.F. pilots for a moment, Kirk stared about, instinctively looked for Tank. But there was nothing that looked like the ape anywhere—just R.A.F. blokes in tropical kit.

"The Heinkel?" he asked. "I swiped it from a mob up at Dulit. It's a long story and I want to tell it to your C.O.—some one official."

"It *must* be a long story," a chap with the rings of a Wing-Commander on his shirt snapped. "What sort of a game do you call that bombing? We spotted you dropping 'eggs' on the Sandakan power station. You can't talk yourself out of that!"

"Power station? You're mad! I had no bombs of any sort. I was at something like 6,000 feet over Lubuk when I saw all the lights go out. I was looking for this field when the lights went dead, and then an Italian Breda—I think it

was a 65—attacked me and I had to pink it. It went down about ten miles from here in the jungle."

The faces of the men in khaki changed immediately and there was a muffled conversation off in one corner of the room. The Wing-Commander finally came up and said: "You may be telling the truth, and we're going to take you to the Governor. A lot of queer things have happened here tonight. How do you feel?"

"Wacky. What the deuce happened to me, anyway?"

One of the men poured a scotch and soda and handed it to Kirk. He took it and drained the glass in one gulp.

The Wing-Commander went on: "You were lucky. Your bus didn't catch fire. Most of ours did."

"But she went right over on her back—for no reason," argued Kirk, getting to his feet. He was shaky, but alert, now.

"Of course. You can't land a fast ship on wheels with no rubber on them," the Wing-Commander explained. "We all suffered the same thing. The damn stuff did something to all the rubber around here. It's a good thing you did

crash. We'd have figured you sprayed or discharged the stuff. Now we don't know *who* did it."

Kirk tried to fathom just what they were saying. But none of it made sense. A chemical of some sort must have disintegrated all of the rubber—a solution that took the tires right off the wheels.

"Wait a minute," he exclaimed, rubbing his eyes and steadying himself again. "My crate quit cold on me, too. Ignition went out. The radio wouldn't work. Then I went over on my back. But where's Tank?"

"Who?"

"Tank—my man. He was in the back seat when I went over."

A young Squadron Leader broke into the conversation with the explanation: "He cleared off the minute you hit. We saw him running like mad."

"That's queer," muttered Kirk. "I wouldn't figure he'd leave me like that."

"That's why we thought you had something to do with all this. He headed for the jungle, going toward the south-east."

Kirk pondered for a moment and then said: "He probably took a thump on the

noggin and is running wild. He'll be back."

The British pilots carried on a muffled conversation again in one corner of the room and Kirk lit a cigarette. Finally, the Wing-Commander came forward and said: "We can't drive a car on the station. All ignitions gone. We'll have to take a trap of some sort. There's one outside now. Want to come along to the Residency?"

"Yes. I think I ought to. The Governor will be glad to hear what I'm going to tell him."

"I'm sure he will," the Wing-Commander muttered.

THE RESIDENCY was typical of British Government posts in the Far East. It lay in a tropical park, with its front steps throwing strange lights on a lotus pond that crept up to one side of the wide driveway. Native troops in gaudy costumes were on guard and there was an air of excitement, even at this early hour. The high-pitched chatter of Dusans and Bugis rattled in direct contrast to the low, crisp voices of the British.

"I don't know whether they were able to get word through on the telephone," Wing-Commander Evans said, as he threw the reins of the shaggy pony to a Dusan at the foot of the steps. "But I am sure the Governor will see us at once."

"He should," commented Kirk. "It seems as though you birds have a first class crisis on your hands."

Evans ignored the comment and hurried up the wide, white steps and whispered to a Colonial guard who was on duty at the door. They were allowed inside the reception hall, which was garish with Malay decorations and teak furniture. Sleepy-eyed Foreign Service officers in various stages of dress and undress were hurrying from room to room, indicative of the state of affairs.

The Governor would see Wing-Commander Evans and Mr. Kirk at once, an orderly informed them.

The British official, a keen-looking individual with slate gray eyes, a white mustache, and a grand military bearing, in rumpled whites, greeted Evans at once and threw a questioning glance toward Kirk.

Evans opened with: "This is the man who landed the German Heinkel at the station, Your Excellency. He has some interesting statements to make, I believe."

"All right. Sit down and never mind the 'Excellency' business. We can't waste time. Now what do you know about this affair, Mr. Kirk?"

"It'll take a little time to tell, but it will be worth it," explained Kirk. Then for half an hour he outlined in general the workings of the Circle of Death, the recent events at Dulit, and his escape from the lethal chamber of the volcano.

Both the Governor and Wing-Commander Evans listened attentively—and with something akin to fear in their eyes at times.

"I've heard of both Cockosaert and von Audemars," the Governor muttered reflectively. "But Tamuracho is a new

one to me. They evidently planned some major move here in Borneo that would draw the British forces out of Singapore which would give them an opening—perhaps a Japanese opening to attack Singapore."

"Or the Philippines," prompted Kirk. "Possibly," agreed the Governor. "Then, with the British well occupied here in the Far East, the European Dictators would have a splendid chance of making their next major move—possibly in the Mediterranean. A clever and devilish plan, Mr. Kirk. You say you shot down the Italian—er—Breda plane?"

"Yes. We saw it hit near this waterfall I just mentioned."

"That's up near Salak," explained Evans. "I know the spot well. But it will be hard to get to. As a matter of fact, I don't know how we can get to it until all the damage has been repaired."

"You know, of course, what happened tonight, Mr. Kirk?" the Governor asked.

"Only a sketchy explanation—something about rubber," Kirk replied.

"Um! That's all, eh? Well, I might tell you that nothing quite like this has ever faced me on any of my many posts throughout the Empire. What it is all about is beyond me. And how it was carried out is an even greater mystery. All we know so far is that a German Heinkel—carrying no markings—bombed the Sandakan power plant. And, as you can see, we are making the best of candles and oil lamps. There is no power anywhere about here.

"I saw that actually happen—from about 6,000 feet," said Kirk.

"But you didn't see what happened after that. For some strange reason everything composed of rubber has been mysteriously changed into—Well, into just a dried or flaked composition that immediately breaks down into an ashy substance."

Kirk frowned and his keen mind immediately saw the possibilities of such a widespread chemical change. No wonder he went over on his back. No wonder his tires disintegrated. No wonder his ignition system went out and his motor conked.

His mind raced on as the Governor and Wing-Commander Evans continued the conversation. He reflected on the fight with the Breda and Tank's effort to shoot the Italian ship down. He knew Evans and Governor Mayne were tracing the events of the night as they had experienced them, but he was now considering them from his own viewpoint.

Then he remembered Tank again. Tank, his guardian, his ever-loyal pal. Tank was somewhere out there in the jungle. Something only his animal instinct could tell had called him from the crash of the Heinkel back there to Salak. Tank alone, a civilized ape, trying to solve the mystery of the Breda!

"We've cleared off all the crashes as best we can, sir," Evans said. "We won't be able to get a ship off the ground until we get more ignition cable, coated wire, and all that sort of stuff. It will take some time to re-wire and re-tire even one plane."

"There's nothing nearby—such as a

seaplane—that wouldn't need tires?" inquired the Governor.

"There might be a small flying boat up at Kudat, but we can't be sure they have any rubber left in their ignitions either."

"Wait a minute," snapped Kirk suddenly. "What about an armored car—something that doesn't require rubber tires?"

"That's right!" beamed Evans. "We have a Mark II.B light tank at the air-drome."

"On metal treads?" queried Kirk hopefully.

"Yes. Of course."

"But what about the engine—the rubber there?" the Governor asked.

"The Mark II.B tank is gasproof from front to rear. She'll work," Evans answered.

"Come on! Let's take that tank and find Tank!" cried Kirk.

WHAT THE DEUCE are you talking about?" the Governor asked, fingering the tips of his mustaches, "a tank to find Tank?"

"My mate—my gunner man," grinned Kirk. "He's a trained ape, this guy I've been telling you about all the while. He works with me all the time. I'll bet he went back to that crash."

Both Evans and Mayne exchanged glances of mystified astonishment. The idea of a British tank being sent out to find a trained ape was more than they could comprehend. It was ridiculous.

"But why?" asked Evans. "What would that get us?"

"Don't you understand, Evans?" argued Kirk, snubbing a cigarette butt into a jade ash tray. "Tank, you see, went off on his own for some reason. He sensed something—that's it, sensed something back there none of us would be able to figure—and so he went back. There's no telling what he had in mind or what he will find. We've got to go back there after him and find out!"

Evans appealed to the Governor, whose face now looked like a disappointed walrus! The Governor steadied himself and swallowed a sturdy peg of brandy in one gulp. He drew in a deep breath, smoothed his hirsute handlebars, and said: "Well, it can't be any more mysterious than it is now. You can do it in a couple of hours, can't you, Evans? After all, I suppose we should try to follow up on that crash and see if there's anything there that will give us any idea as to what happened."

The Governor then sat down, a tired old man who had given up to the mysteries of a modern age—airplanes, Wing-Commanders, tanks, rubber-consuming gas, and trained apes. He wished he were back in London parading the Birdcage Walk.

"Come on, Evans," boomed Kirk. "Let's get that armored snail and go after Tank. We can first make sure he isn't back, and then try this Salak place you know about."

They left the presence of the Governor unceremoniously and hurried down the steps. They leaped back into the trap and laid a heavy reed across the flanks of the shaggy pony.

"You Americans!" muttered Evans,

with an admiring grin spreading across his face. "You like to get things done in a hurry, don't you? Poor old Mayne will be weeks getting over this."

"I fear the whole Empire won't ever get over it, Evans—unless this mess is cleared up pronto."

They laid on the reed again, and the Pegasus in the shafts increased his pace down the cobbled road to a full eight miles an hour.

"I'm telling you," confided Kirk, "the more I think about it, the more I am certain that Tank spotted something I missed. He wouldn't barge off like that, leaving me in a heap under the Heinkel. Apes are queer birds, Evans."

AND FROM THERE all the way to the field, Kirk told the Wing-Commander of the strange adventures he had had with Tank since the hair-raising experience at the Berlin Zoo more than two decades before.

"I wouldn't miss going with you on this junket for all the planes in the Air Force," Evans finally said, as he tossed the reins over to an anxious eyed Aircraftsman. "Come on! The tank is over here in this shed."

They made their way past the hangars where mechanics were feverishly working on the planes, ripping out the crippled ignition systems. Their faces were blank masks of apprehension, streaked here and there with dabs of grease. They turned on their raised work-stands and cast anxious eyes toward their Wing-Commander—hoping that he had something encouraging to say about the matter.

But Evans had only more orders, and he spat them out with machine-like precision.

"Come on," he added to Kirk. "Let's get going. I want to see this bloke Tank, for he must be a beauty."

"Well, hardly," smirked Kirk. "But he'll do until some prettier gorilla comes along."

They tore open the doors of the shed, and there stood a gleaming metal monster, trim in olive drab paint—with the muzzle of a three-pound pom-pom gun sticking out of its upper, rotating-turret. The car ran on flexible metal treads and, as Evans had stated, was completely enclosed and obviously gas-proof.

The Wing-Commander twisted the release lever that unlatched a small steel panel in the bow of the tank's steel body. He lifted the panel and crawled in. Kirk followed. Inside, they found an amazing display of swinging saddle seats, instruments, a single gun-turret and a gunner's platform. Evans made a quick inspection of the cables and wire, and everything appeared to be in good order.

"You take that seat under the pom-pom," ordered the Englishman. "Stick one of these helmets on or you'll bash your brains out when we're underway in the rough stuff."

He adjusted several ignition and fuel levers, pressed the starter, and the Lanchester motor opened with a resounding roar. Evans let her run for a warm-up, meanwhile handing two small rubber plugs to Kirk, indicating with his fingers that they were to go in his ears to

protect the delicate hearing drums.

Evans, sitting in the control seat, peered through a small oblong of shatter-proof glass, and drove the tank out into the open. The steering mechanism consisted of a wide-angled Y-handle, fitted with grips and carrying Bowden cable controls to the engine. There was a simple clutch device on the floor beneath the panel.

Once outside, he throttled the motor down, checked the fuel tank, ammunition magazines, and two-way radio set. He nodded to Kirk, reached forward, closed the entrance hatchway, and sealed it. He opened two vent plates below the oblong peep-hole and fastened a small map before him on a set of spring prongs.

"All set?" Evans bawled back over his shoulder to Kirk, who was trying out the breech of the pom-pom.

Kirk slapped him on the shoulder and nodded.

THE TRIP along the baked roads of Sandakan was reasonably comfortable. But once they left the palm lined highways and entered the jungle and bush, where they had to steer by compass, Kirk realized for the first time what tank crews have to put up with.

For what seemed like more than an hour, "Betsy," as Evans had named the tank, bumped and lurched across brooks, decayed tree trunks, and rocks. She squealed as her treads slipped over the mud and slithered over the rank vegetation. And as they bounced and thudded, Kirk was glad Evans had given him the tank helmet. His shoulders were already bruised and his chest was marked with the blows from crashing into the ring of the turret.

Finally, they came out into a reasonably open sector that ran toward a low range of blue hills. Ahead they could see the thicket of mango palms, cassava,



chincona, and wild sugar cane which hid from view the stream that was being whipped to a froth by the waterfall remembered by Kirk.

Evans halted, throttled down, and checked with "Coffin."

"This is where the Breda came down," said Kirk. "I remember that thicket over there. The waterfall must be just beyond it. Can you make it?"

"I'll try. But it may be bad up ahead. Would you mind walking ahead to check the swamp? Take a gun with you. There's one or two in a rack behind."

Kirk was glad to get out of the leaping juggernaut and get a breath of clean air. He found a Webley revolver, stuck it in his breeches pocket, and crawled past Evans who had unlocked the hatchway.

"If I only had a bugle now I'd feel like a Boy Scout," grinned Kirk through the ventilator.

"I'll see that you get your merit

badge," soothed Evans. "But mind the hooded cobras!"

Kirk liked this guy Evans. He was one of his own kind, and the American was glad he was mixed up in this thing. They were in a mess and they both knew it. What it was all about they had no idea. But Kirk was certain that the Circle of Death was behind it all. They hadn't gone to this extent—this rubber-consuming gag—for nothing. He wondered whether it could be another link in the plan old Cockosaert had talked about in the gassy interior of Mount Dulit not many hours before.

The Circle of Death had planned to take Brunei, farther up the coast, and in all probability had managed it. There was no telling whether the strange gas had been discharged up there or not, but Cockosaert had spoken about a plan that included the capturing of this portion of Borneo and later on the Philippines, which lay only some 450 miles across the Sulu Sea.

Kirk pondered on all this as he strode carefully on, testing the ground for the tank.

He was now making his way across an area covered with wide-fronded foliage, not unlike skunk-cabbage. Beneath, the ground was black and fertile, but in spots it threatened to become soggy and ooze off into small areas of swamp land. Just ahead lay a light thicketed area shielded with light second-growth. That would be easy for "Betsy," if the ground was anything like solid.

He managed to guide the tank safely into this area and was selecting the better section to traverse, when his ears suddenly caught a familiar sound. First there was a flutter of gaudy-plumaged birds cascading from nearby tree-tops with their challenging squeal of the tropics. And then came the ever familiar forest scream of an ape!

The cry came from an indistinct source, but it was welcome music to Kirk—for that cry could have come from no one but Tank!

Kirk turned back and waved an encouraging arm to Evans.

THEN, as if some strange instinct had touched hidden keys somewhere inside the ape, the cry changed to a warning wail. It was repeated in a tone that carried both authority and caution. Kirk dropped to one knee, peered ahead. He signalled for the tank to halt, went on ahead, then listened again for the call.

It was not repeated, and a new fear crept into Kirk. A length of twisted barbed wire seemed to be twisting around his middle, sending jolts of electricity through his body. He openly winced but hurried ahead cautiously until he found himself approaching the edge of the thicket.

Then, with unbelieving eyes, he saw two large elaborately camouflaged canvas hangars, their draped doors partly opened and the glint of equipment inside! He waited and studied the scene. There was no one present—at least, no one in sight.

Kirk hurried back to where he had left the Mark II.B and signalled for Evans to open the hatch. He slipped

inside and explained to the Englishman what had happened.

"We must make sure that hatch is gas-tight," Evans said. "We can't take a chance on that stuff now. How far ahead is this clearing?"

"About 150 yards. There's two hangars in there—beautifully camouflaged—but I can't see anyone around."

"But your monk gave you a warning cry?"

"Absolutely. There's something murky up there."

"Come on then, let's clean it up," grinned Evans, his face abeam with anticipation.

"Carry on, Skipper," replied Kirk. "But look out for that gunner of mine. He's likely to be around somewhere."

"You do the shooting, I'll drive the 'orses," answered Evans, letting the clutch in.

The tank rumbled on, lurching and bouncing as it shoved the light trees aside, and nudged her shovel-nose through the underbrush. Kirk jerked the breech lever of the pom-pom and placed a six-shell clip into the loading block. He thumbed a knurled knob to single-shot action and peered through the glass-covered aperture set in line with the gun sight.

They were nearing the clearing now. Evans twisted in his seat and gave Kirk a final glance of assurance before he plunged on through.

They could hear no sound outside because of the rattle of the motor, and Kirk wondered whether his ape was issuing any further information. He waited until the tank lurched out into the open, then studied the layout while Evans steadied "Betsy" in the clear.

"I'll hold her here a minute and see what happens," said Evans. "You be ready in case they show up."

The clearing, now they had time to study it, was perfect for a hideout spot. It was long, reasonably wide, and as level as a billiard table. The hangars were huddled deep into the foliage and could never be seen from above.

"What a plant!" said Kirk, admiring the real estate. "But what the devil is this all about?"

"Let's skirmish it," replied Evans. "I'll run around the edge here and try to get to the hangars. If it gets hot we can dive back into the bushes."

"Betsy" waddled around on her tread and started to crunch along the edge of the clearing while Kirk watched for action over near the hangars. So far there was not a move, or a sign of life.

But when they reached the end of the clearing and were just about to turn left to cross toward the hangars—bedlam broke loose!

FROM SOMEWHERE deep in the field near the hangar, an automatic weapon of high caliber opened up on them. Kirk saw the streaks of fire several seconds after the first burst biffed into the tank's mid-section.

Evans slammed the slitted steel plates across the shatterproof glass and squinted through the peep-holes in them. Kirk managed to get set while "Betsy" eased into the thicket again. He squeezed the trigger and the gun slammed back and

almost flattened him against the turret top. He moved to one side and continued to fire.

Evans was now out of his seat and was poking a Bren gun through a rubber-bound slot. He, too, opened fire on the mound ahead, and his shots sent up a fountain of stones and damp earth.

Cr-r-r-r-ump!

The pom-pom spoke again and the little tank shook under a wave of blasting, ear shattering concussion.

"Got 'em!" cried Evans excitedly. "You blew their blooming rampart away. Let's go after them and tread on their whiskers!"

Kirk never heard a word the Englishman said, but he sensed that "Betsy" was moving forward again. He managed to get another shot into the mound again before he had to hang on to keep his teeth in their gums.

"Betsy" waddled on and they saw three heads appear. Kirk fired, but the shot went wide. The trio of men leaped out, ran like madmen toward the back of the hangars, and Kirk blazed another shot which went wide over their heads.

Evans halted "Betsy" near the depression and saw that three bodies were slumped over what appeared to be a heavy gun. Then Kirk yelled—for out of the tree tops above them a gaunt, long-armed figure dropped and hurled itself at the racing men.

"That's Tank!" Kirk yelled. "Hey, Tank!"

Evans sat stupefied as he watched the strange creature grab two of the men in his long arms, jerk them toward him suddenly, and crush their lives out. Tank dropped the men and came back toward the tank, peering strangely as Evans kicked open the hatch. Kirk dived out first, ran up to the simian, and threw his arms around him.

Evans watched the affiliation of civilization and the jungle, with mixed emotions of amazement and awe. He saw Kirk grab the ape's shoulders, hold him off, and peer into the blank mug that simply stared back. The ape was still dressed in what was left of a pair of white slacks, a Navy blouse, and the canvas tops of a pair of sneakers which now had the grotesque appearance of spats, since the rubber soles were no more. They had gone with the Heinkel's tires, ignition insulation, and the rest of it.

Evans, satisfied now that all was reasonable well, crawled out and obeyed Kirk's silent command to come forward and get the okay from the ape. As he approached, Kirk, with his arms about each, conveyed the idea to Tank, who allowed his mug to relax somewhat while he rubbed his great hands up and down the Englishman's arm.

"You're in," explained Kirk. "I had to explain to him that you were on our side."

"I'm damn glad I am, too," muttered Evans, gently patting the ape on the shoulder. "Did you see what he did to those poor devils?"

"I'll bet he's been waiting up a tree for that for hours. He can be nasty if he decides he's facing an enemy. But he's a grand guy."

"I'll take your word for it," muttered Evans, as Tank swished away and dived into the trench. He tossed the bodies of the men away and snatched at the field gun. Then, before their eyes, he twisted it to junk—bending the steel barrel, breaking the cocking handle off, and shattering the walnut butt across a rock.

"Just like that," reflected Evans. "I hope he doesn't get playful with 'Betsy'."

"Don't worry. He won't, since he saw both you and me get out of it. He'll behave with me around."

"Righto! 'Stick around,' as you Yanks say," grinned Evans. "He might start pulling the armor off—just to keep in trim."

"Let's have a look around here while we've got the chance. We might not be here very long until some one pops in at us again," suggested Kirk.

"But we'll take 'Betsy.' We might need her again. This is *too easy*," said the Englishman.

Evans climbed back in and headed the tank for the hangar, while Kirk and Tank walked alongside, keeping a close watch on the hangar. Evans pulled up near the opening, then decided to run her nose inside a short distance. Kirk and Tank, working together now, crouched behind the tank until they were certain all was clear.

Evans came out from the hatchway, startled at what Kirk was pointing at.

"What the deuce do you make of this?" the Englishman exclaimed. "Look at them. New Breda 65's—about ten of them!"

"Yeah. And look at what they got painted on them," said Kirk, fingering his gun as he walked in. The Rising Sun insignia of the Japs! Italian planes with Nipponese insignia!"

Kirk put his finger on the round, red disc on the side of one of the fighters. The finger came away scarlet. The paint was still wet!

"GET IT, EVANS?" he said quietly, still looking around cautiously. "Get it? They flew these things here and put the Jap markings on only a short time ago. Mean anything to you?"

"What does it mean to you?" asked the puzzled Wing-Commander.

"Part of this Circle of Death gag. They have provided these fighters for the Japs. They were brought here somehow—probably catapulted off a mother ship—and are now probably being fixed up for a Jap attack!"

Tank, Kirk, and Evans went over one of the ships carefully. There were two guns under the hatch of each for an observer—Breda-Safats of 7.7 mm.—two more under the hood, firing through the airscrew, and four guns in the wings.

"What a find!" beamed Kirk. "Have you noticed? The ignition cables and all wiring is carried in some sort of plastic material. I'll bet the tires are some sort of faked rubber, too."

They inspected the wheels and discovered that they were the spring-leaf spoke type, and the tires were spring steel coils carefully fitted to the rims.

"We've got to get these babies out,"

snapped Kirk. "How soon can you get pilots here?"

"I can radio through from 'Betsy.' I think we have that range."

"Sure, but you can't get them if their sets are still out of order back there. Try it, anyway."

Kirk still had an idea that there was no radio channel open to Sandakan, and that Evans would have to go back in "Betsy." *Anything* could happen in the meantime.

Then Kirk and Tank made a careful search of the place while Evans tried the radio set in the tank. They discovered that both hangars were full of planes of the same type, that there was a reasonable amount of supplies and spare parts, and that all of the Bredas had been fueled to the limit.

"Queer," reflected Kirk, trying to fathom the mystery. "Why were these ships brought here, hidden, and then left in charge of a handful of men? Where are the pilots who flew them and why are they being stored here all ready for action?"

He glanced at Tank, who had been following him about like a devoted retainer.

"And what have *you* been up to since you left me? Kirk suddenly exclaimed. "What the deuce have you been doing, Tank?"

The big ape stood still, twisted his pinkish-brown mug, scratched his whiskers, and padded up and down on his big bare feet. He had all the airs of a youngster who had been caught on the top step of a ladder in the pantry.

"You came back here somehow. But what did you come back for? You saw the other Breda crash, and you probably found it for some reason. What was that reason?"

The ape watched him, his brow even more wrinkled than usual—as if he were trying to fathom what his master was trying to get at. Kirk moved closer to him, stared deep into those hazel eyes, and put on a mental effort to pierce the mind of the ape.

"He came back to search for the wreck. He might have found it, but he never has revenge in his mind. He wouldn't outrage a corpse—but he might . . ."

That was it! Tank would come back—just as he would have done under ordinary conditions—and searched the wreck and the clothing of the pilot!

"Come here, Tank," the American said. "Let's look through your pockets."

A strange light lit up the ape's face and he began fingering awkwardly with his long talons through the pockets of the Navy blouse. He worked furiously, then came away with a wad of soiled papers and a thin leather wallet.

"Now we're getting somewhere," smiled Kirk. "Let's see what you discovered, old boy."

The wad had been rudely twisted into a lump and roughly stuffed into the small blouse pocket. The leather wallet was a *Ministero dell Aeronautica* pilot's license, issued to one Aldo Ravenna, of Turin. There was a badly bent compass variation card, a nondescript business letter, a bill for a revolver bought in Palermo, and a crisp

quarto size sheet of note-paper.

"This looks like the business, Tank. You're getting good," grinned Kirk, slapping the ape on the shoulder. "You're learning, boy!"

The sheet was a set of cryptic orders involving the name of a Japanese aircraft carrier, the new *Akudo*—recently completed from a British liner that had been sold several years before for scrap. There were names like Sandakan, Borneo, Philippines, and Lubuk. There was a date and a time specification that made Kirk twist sharply.

"Come on, Tank. Let's see what Evans has to say about this."

They hurried over to "Betsy" just as Evans was crawling out.

"Nothing doing," the Englishman



muttered. "Can't raise a spark of any sort. What's up!"

"Plenty! Look here. Can you figure out any of this?"

"Let's have a look. Where'd you get it?"

Kirk explained while Tank danced about like a trained bear.

"Damned lucky for us," Evans said, after a quick but careful glance at the paper. "They're going to attack Sandakan and Lubuk—that's the other R.A.F. base up the coast—tonight! We'd better set fire to all these ships."

"What for?" Kirk demanded, somewhat amazed.

"Why not? We can't get them out, can we?"

"If you can get pilots up here in time we can."

"You mean I should take a chance getting back and bringing them here?"

"That's right. We'll stay here and hold the fort."

"It's an idea," agreed Evans, beaming. "This paper says they are going to try for a landing—using the *Akudo* loaded with Jap planes and Jap marines—so that they will have a jumping-off point to attack the Philippines."

"Well, what are we waiting for?"

"Let's figure this out. I could go back in a couple of hours. You could stay here with one Breda ready to take off. If anyone came along, you could hold them off while I tried to get pilots back here."

"That's one idea," agreed Kirk. "Or we could take two out. You see, I'd like to practice on one. Anyhow, you fly a Breda to Sandakan and bring a couple of pilots back with you. Then start the others on their way. How do you like that?"

"That's good, too. It's quids to quinces they'll be back—probably with bigger bombers, bringing extra pilots to fly these Bredas for the big show which is slated for 11 o'clock tonight."

They left "Betsy" in the shadow of the hangar and ran two Bredas out. Tank was a big help at this task and in no time they had the engines running and were climbing aboard.

"You go ahead," ordered Kirk. "Go

back and bring as many of your guys back as you can get aboard. Hang 'em on meat hooks if you have to."

"Righto. And the best of luck."

The Englishman fumbled with the controls for some time, and then whipped the Breda around, and, with a wave, gave her the throttle and thundered down the landing field. Kirk watched him get into the clear, turn northwest, and hurry back to Sandakan. Then he gave Tank a signal. The big ape climbed aboard and fumbled with the butts of the Breda-Safat guns.

"That's right, mug, take 'em out. And if you have to use 'em, don't waste any slugs," ordered Kirk over his shoulder.

KIRK FUMBLER with the controls. He worked out the statements printed on metal plates in various parts of the cockpit until he found the details of the flap gear, the gun loading sequence and the throttle adjustment. Then he took off, hammering down the green turf runway, and hoiked carefully over the trees.

The Breda flew well. She was a little heavy laterally but responded well to the throttle and showed plenty of speed when Kirk turned on the juice. He tried one or two maneuvers, whip-stalled her twice, and satisfied himself that he could handle her. As she came out of a snap roll, Kirk glanced over his shoulders at Tank—and then immediately whipped the Breda around and set himself for action!

A brace of B.R.20's came out of nowhere and peppered the Breda with some heavy caliber stuff. Kirk whipped over hard and saw that two Italian Fiat heavy bombers were evidently on their way to the long green strip below.

Tank had spotted them first while Kirk was trying out the Breda, and before Coffin could whang her around to get in a full shot from his front guns the ape was spraying the two Fiats with a heavy dosing of Safat lead.

"Hold it!" screamed Kirk. "Wait a minute!"

Tank obeyed, purring contentedly through his massive nostrils as Kirk brought the Breda around. The two Fiats slammed more lead at them, and Kirk had to slip her clear before he could come around to set his guns on the big bombers.

"They must have been given the tip-off," he muttered, waiting for his opening. "Probably returning with pilots to get those planes out of here. Well, we'll see if they can take it."

The Breda screamed through the skies and vomited leaden hate in long gleaming streams. The lead Fiat B.R.20 took the tracers full force in its starboard wing root and Kirk drew the stick back gently and hoiked his line of fire so that the leaden stream continued to saw through the airfoil supports of the Italian ship. He knew he had scored. Its wing buckled, the Fiat was falling.

But before Kirk could whang around again, something caught the Breda full in the quarter-deck!

Tank let out a soul piercing scream. A plume of flame and smoke, fluttering back over the sealed hatchway, told Kirk that his fuel line had been hit—

their ship was in flames!

Kirk gave Tank one look, but the ape twisted around, ripped out the guns again, and opened a wild garden-hose fire on the bomber that was banking behind them. A hopeless but gallant stand to the finish!

Kirk peered over the side and saw the landing strip directly below him. He acted fast now and slithered the Breda into a knifing side-slip. The trim-winged bullet-like ship slipped down. Coffin set the flaps to their limit. The bomber was coming down after them, regardless of the wild fusillade Tank was slamming across his own tail.

This was the end—unless . . .

Kirk waited for a thud of bullets as he slipped toward the field. And he waited for that trowel-like wing-tip of the Breda to dig into the lush grass below. The sideslip was taking the flame and smoke clear of the fuselage, but the hungry fire would soon be gnawing at the ship's vitals.

He waited a few more seconds, expecting any minute to feel the fire wall slide back to his knees and snuff him out of existence.

They were almost down now, and approaching the jungle runway at express-train speed. Kirk reversed his rudder, bringing the nose around. Then a short savage shove at the throttle knob and the Breda eased around into a slow, fluttering glide. The flaps held and she seemed to hang on unseen wires for a moment.

A curtain of flame and a shroud of smoke whipped up as Kirk went through the automatic motions of landing.

Thump! . . . Thump! . . . Bang!
. . . CRASH!

They were down. And by some act of Providence Kirk had forgotten to lower the landing gear. Thus the belly-landing had prevented them from barging on through into the jungle brush at the end of the runway.

The rattle of a Safat gun continued as Kirk fought to get clear of the wrenched cockpit.

"Hey, Tank!" he bawled. "Some of your muscle here, lad. Get this damn bus apart!"

The ape stared at Kirk for some seconds, peered out of the shattered hatchway as if he were astonished to find himself on the ground, and gave a final jungle snarl at the Fiat which was still peppering at them from a tight turn above.

THEN, amid a wild barrage of Italian lead, Tank went bull-in-a-china-shop. His long paws grabbed lengths of stiff dural and his thumbs constricted. The stiff metal gave like lead-foil. He snatched at stringers, grabbed them with his firm yellow teeth, and tore with savage rage until the fuselage of the Breda had been ripped apart like a shoulder of beef in a lion cage.

Smoke blinded them and flame seared their flesh as they fought their way out of the cockpit. Kirk grabbed a short lug, twisted it, drew out the brace of Safat guns, and tucked them under his arm as he turned for the hangar.

Then he remembered "Betsy."

He bawled at Tank, who was gnashing his teeth at the Fiats.

"Come on, you fool! Don't stand there baring your dentistry. You can't do anything about them out here!"

At last the ape caught on. Together they ran to "Betsy," lifted the metal hatch, and clambered in. The ape was ill at ease for a moment, for somewhere back in his simian mind he must have remembered being a biological exhibition in a somewhat similar steel cage, placed on view to be gazed upon.

"Take it easy," argued Kirk. "Sit there while I play the organ."

Kirk charged the pom-pom and waited to see what the remaining Fiat would do. He rammed home another charge of shells and watched. The Fiat was being flown in a wide circle now, as if the pilot was not quite sure just what to do. "Betsy," fortunately, was in a secluded position just around the corner of the hangar, and Kirk hoped they had not spotted the British tank.

"We'll get 'em cold if they try to land," he muttered quietly.

The Fiat showed every indication of making a landing. Kirk patted Tank on the shoulder and soothed him, for the ape was watching the bomber through the peep-slits, and showing increased anxiety.

"Take it easy, boy. We'll get 'em if they land. I'll pick out their cylinders one by one and then cut their wheels off. You watch, boy!"

The ape purred, gave Kirk a grateful glance, and then rubbed his great beezee in anticipation.

Kirk took an angle sight past the corner of the hangar and figured he could just make it—if the Fiat landed far enough up the green strip. Still, he took no chances, but stepped up and started the Lanchester motor so that they could run her out farther should it be necessary.

They watched again once the engine was purring quietly, and saw the Fiat turn in for a landing. Coffin Kirk's eyes



sparkled with glee and anticipation, for he saw an easy capture. He moved back to the saddle seat below the gun turret, and reached for the trigger as the Fiat swished around and set herself for the final glide.

"Now take it easy, Tank," he warned. "You've had enough scrapping to last you for awhile."

But Tank was not satisfied. His eyes tightened into slits and he pawed at knobs, handles, and parts of the interior.

"Now what's up?" demanded Kirk, for he knew the animal had drawn on his jungle instinct to scent danger. Suspiciously, he peered about through the slits.

Then, just as he was drawing a bead on the bumping Fiat, something blinded him! He remembered hearing Tank let out a fiendish squeal, and then four million Roman candles seemed to go off

in his brain. Concussion blasted all life out of his muscles and battered the electric reaction from his nerves.

COFFIN KIRK'S eyes were in a world of blackness. He knew nothing of the passage of time. He could hear voices, but they meant nothing. Then abruptly he could see strange figures in trim black uniforms. And his returning vision recognized the hated insignia of the Circle of Death on breast pockets!

He put on a silent struggle to gain full possession of his powers of concentration. He listened again, closed his eyes, and waited. He caught words like "Philippines," "Akudo," "Breda," and "Cockosaert"—and then he knew. He struggled with himself and had to restrain the desire to scream.

Kirk then tried to piece it all together: A Fiat bomber coming in to land . . . "Betsy" and her pom-pom . . . He was just about to fire—and then a crashing nothingness . . . Something had slipped up . . . Something had hit them . . . What?

He rolled his body gently, peered around. Near him, in a half reclining position, lay Tank—trussed and bound.

That was queer! Who could have tied Tank up? They must have gassed them. No, "Betsy" was gas-proof. An anti-tank shell must have hit the tank.

A hundred scenes flashed before his eyes and he saw Evans—Evans, the Englishman who had relied on him. Evans, coming back with as many British pilots as he could carry. Coming in to land—Englishmen coming to their doom . . .

"Hell," he muttered, glancing over at Tank again. "Got to get out!"

He moved cautiously, as every muscle move brought on jolts of nerve punishment. The men in the black uniforms formed a dim circle off near the opening of the hangar now. They were at an alert position. Something outside was attracting their attention—something with a throbbing boom to it.

That was it! Evans was coming back with his first load of pilots. They were waiting for him—waiting with guns!

Kirk squirmed again and brought his bound wrists up to the long slender fingers of the ape. He shoved against them and whispered over his shoulder.

"Come on, Tank! Go to work, boy! Untie these knots. Let me loose, Tank!"

He waited, and then the hairy fingers began to move. Swiftly and certainly, too, for they were trained and had the background of jungle years at their tips. Fingers that replaced the lack of what men call intelligence. Fingers that were as true and as strong as steel.

It seemed hours before the bindings were off. But once his hands were free, Kirk lay low, turned slightly, and then untied the ropes knotted at the beast's back.

"Now—now, Tank! Can you hear me? Clean the damn lot of them out, and don't stop until I order you. To the finish, Tank!"

Words, yes. But Kirk's pointing finger, directed at the group of men huddled in the hangar doorway, was the "Finger of Death" as far as Tank was

concerned. All he knew was that these men were their enemies and they had to be killed. Animal instinct came to the fore, directed by the intense loyalty to the human being he had accepted as his master.

Kirk looked into the ape's eyes with glances that carried volumes of words. Then Tank eased away like a wraith and skirted the rear of the Bredas. Kirk waited, knowing that the gorilla must carry out the first move to make sure their plan would work.

Kirk flexed his muscles, tested his vision on points at various distances, then got up and moved quickly to the nearest Breda. Here he removed a Safat gun from its mount and took the metal magazine with it. He dropped to the ground, carefully cocked the weapon, and waited for Tank to go into action.

Sure enough! Tank suddenly appeared on top of the front Breda, crouching and poised for a jungle attack. There was an instant of deep silence—then an unearthly bellow of animal rage filled the hangar as Tank charged upon the foe.

Kirk darted into the clear and opened fire on the group which stood spellbound and unable to draw sidearms from hip holsters. Kirk then held his fire, equally spellbound by the ferocious attack of the simian who was cutting a wide swath through the group, swinging the first wretched swine he had grabbed by the ankles. There was the hollow *thock, thock, thock* of skulls crashing together, the piercing crack and crunch of breaking bones, and the dull leaden thud of pounded carcasses.

Tank was having a jungle field day!

Into the midst of it all ran Kirk, his Safat gun covering the lot. Two game devils tried to get out their weapons and put up a fight, but a swinging burst from Kirk's gun cut them down.

In twenty seconds a major victory had been scored. The black-uniformed mob lay like reaped wheat. A cruel revenge, perhaps, but nothing compared to what might happen if this band of cut-throats could not be stopped. They represented a far greater threat than a few cracked skulls or bullet slashed limbs.

The carnage was ended just as the captured Breda rumbled up to the doorway. Wing-Commander Evans peered out over the front of the Gnome-Rhone cowling and stared at the shambles, unable to figure it all out, until Kirk, with a weary gesture, waved them in.

"WHAT THE DEVIL happened?" demanded Evans, clambering over the tangle of bodies. He grabbed at black Mausers that lay about, and drew a few more from open holsters as he came toward Kirk.

"They downed us and we tried to hold them off with 'Betsy.' But some one conked her with a nine-point-two, or something," said Kirk. "And now I'd give a Breda for a drink."

Quickly Evans produced a leather-covered flask and shoved it toward Kirk. The American unscrewed the top, placed the short neck to his lips, and added a few much-desired thermal units to his constitution.

Around him flashed the movements of British flying men in khaki shorts, light canvas helmets, and sturdy bare knees. Kirk counted at least four. Then Kirk heard indistinct orders and the bellow of the Fiat bomber's warming motors. And he rightly sensed that Evans had "told off" some one to fly the plane back to Sandakan and bring in another load of men.

Mercy now tempered the movements of the Britons, too; for they went to work with a will on the injured men in the black uniforms. First-aid kits appeared as if by magic, and in no time those left alive were carefully attended to. They were bandaged and eased into the wide cabin of the Fiat for the trip back to the base. Needless to state, also, they were securely bound to prevent any possibility of their attempting to re-capture the bomber once it was in the air.

Kirk watched the Fiat take off with decided satisfaction. Tank was wandering up and down nearby, one eye on his master and the other on the quiet pile of dead his own efforts had heaped up.

"We're damned lucky, you know," said Evans, watching the British pilots as they moved three Bredas out for a take-off. "We managed to get a small spark-set radio going back at the station and have warned Brunei and Singapore, but we have no idea whether they got the message straight. What's more, we have picked up messages from the *Akudo*, and there is no question now but that they are on their way. It'll be a devil of a fight—if we can get into the air in time."

There was determination in Kirk's grin. "We'll get into the air, all right. All I'm worrying about now is that they'll find out we have captured their Bredas."

"All right," argued Evans. "Suppose they do. The *Akudo* can't turn back now. She's probably too far this side of the Singapore-Brunei. The Japs will be safer taking a chance on a landing in Borneo than trying to get back through the British defense units now starting out from Singapore. They've begun the mess and they'll have to go through with it."

KIRK PONDERED on that as he enjoyed a cigarette, allowing the blue smoke to soothe his nostrils. He spoke quietly to Tank and the ape slumped down, coiled up, and went to sleep.

"If we could only cork off that way," observed Kirk. "One hour and he'll be ready to rip five tanks apart!"

"When I want some tanks ripped apart," said Evans, with a quiet gleam, "I'll file a requisition for him. By the way, did I tell you? We have a bloke back at the station who's a bit of a chemist."

"I hope he doesn't manufacture your liquor."

"No, nothing like that. The thing is that he's been scraping around and making tests on the ruined rubber—and he seems to have found something."

"About the stuff with which they pulverized the rubber?"

"That's it. He's made a couple of simple chemical tests, and he figures the

gas they used is a combination of carbon disulphide, benzol, and nitric acid. He explained to me that he once did some time on a rubber plantation and knows a lot about the various curing processes they employ. It was a bit technical for me, but his explanation seemed reasonable when he explained it. It appears they smoke the gum with certain chemicals that have to be blended carefully. But if they're not in the proper proportions, the latex element in the rubber goes spiffo and they find themselves with a lot of muck."

"He seems to have hit it," agreed Kirk, sticking his long legs out for a more comfortable position. "They could make a gas like that. It might cost some money. But after all, these devils don't seem to worry about sawbucks."

"Sawbucks?" queried the Englishman.

"Never mind," answered Kirk with a flick of his cigarette. "It's an Americanism for mazuma. Now, how's about getting these Breda busses out of here—and damn quick!"

"I've sent Mayberry off with the Fiat for more pilots, of course. I have three other flyers here, and I'm putting them into the air now to do a local patrol over this place. Mayberry will ferry the rest of the pilots in as fast as he can make the trips. You and I can take one apiece when you're ready, and we can go back any time now and plan the rest of the celebration."

Kirk nodded, lit another cigarette, and twisted with a weary gesture for an easier position.

"There's a lot of work ahead, you know, Evans," he finally said. "We've got to let these men of yours know just what they're up against. You'll have to send one of them around as a despatch rider to let them know for certain at Lubuk and Brunei so that they can put up some form of defense if the *Akudo* gets through and lands a gang of marines."

Evans agreed, then went on:

"The *Akudo* carries about forty of those new Mitsubishi 96's—nasty-looking devils, too. I saw some of them when I was in Hong Kong a few months ago. They look a lot like your Boeing P-26's, and I'd judge have about the same performance."

"Whew!" whistled Kirk. "Forty of those against what we can put into the air will give us a very pleasant evening. By the way, what's the time?"

"Well, it's after noon now, I suppose. Yes, 1:30 to be exact," said Evans, consulting a formidable-looking ticking turnip on the end of a leather shoestring.

"So we've got about nine hours to get ready?"

"Exactly. And in the meantime we can worry about where these Fiats come from and what their next move will be."

"I've already been worrying about that," chimed in Kirk. "We'll have to maintain a patrol over Sandakan in short shifts until we take off for the flare-up tonight—just to play safe, eh?"

"A good idea. It will give my men plenty of time to accustom themselves to the new planes, too."

"Have you had a look at the Breda

bomb racks? Can you use them?" Coffin came back.

"They're adjustable. They'll take our stuff, I feel sure. You know the blokes at the Air Ministry have an idea now and then. They have our bombs built so that they can be fitted into almost any rack, interior or exterior. Jerry taught us that trick during the World War. German rifles in those days would take both German and British ammunition, but ours wouldn't take Jerrys'."

Kirk pondered on that for some time until it was evident that it was time they all got on their feet again. He was weary, but he managed to crawl to a Breda, call to Tank, and take off for the R.A.F. drome outside of Sandakan.

By 3 o'clock the full complement of captured Bredas had been transferred safely. Aircraftmen were making slight adjustments on the bomb racks, pilots were checking their guns, and Kirk and Tank were enjoying a short but reviving sleep in Wing-Commander Evan's cubicle.

A THREE-SHIP patrol droned back and forth over the Sandakan field, covering the area and keeping a faithful watch over the R.A.F. station. For hours now this had been going on. A low wind sang through the hangars with lengthy wails that reminded one of some despairing soul shut out in a storm. The sable-vested night, which had fallen with a churchyard gloom, was flecked here and there with light flashes from open doors. And behind those doors was fevered activity in preparation for the "show" which was soon to go on.

The hours hung heavy, even with the excitement of planning and organization. Men sensed what was ahead, realized that a strange menace threatened. A grim battle for life, for existence, in strange craft unfamiliar to their feel and touch. An enemy who had not as yet shown his head.

Some were to live, some to die, in this battle to come. The goal ahead, whether gained or lost, would find record only in the dreary wordings of secret diplomatic papers. Blind faith in a tradition, a national loyalty, an Empire would drive these R.A.F. pilots on, but the world would never know. A mere "Died While Serving Overseas," would be their epitaph.

Grim, silent mechanics worked like beavers on motors and airframes. Armorers toiled over unfamiliar weapons and fought with strange mechanisms. They all had to carry on. Grimy, sweat-fouled men came down from their vigil aloft, sought the soothing warmth of baths and clean clothing, and prepared themselves for—for none knew exactly what.

Then suddenly the pent-up spirits of preparation were released. The American—a man whose very personality injected throbbing amperage of courage and enthusiasm—appeared among them, followed by that strange, slant-shouldered figure who somehow forged a link between their civilization and the mammoth strength of the jungle. The combination, coupled with man's newest and most formidable weapon, the airplane,

inspired them with a new confidence.

Twenty brand-new Breda 65's now gleamed with aircraft grooming. Gun-muzzles flashed with the glint of oil film, prop blades flashed like broadswords. Portable arc lights threw eerie glows of circular intensity and spread gaunt shadows of men across the oil-soaked tarmac.

In small groups the men stood about, passing on bits of information concerning the quirks and twists of their new mounts, the manner of loading and re-loading Breda-Saftas. A year's training had been crammed into a few short hours.

Wrist watches were consulted. Then the reliable Evans, who was dead on his feet but yet still retained the erect dignity of his responsibilities, appeared.

He called his Squadron Leaders around him and they bustled up, clicked heels, and saluted gravely.

"I could say a lot," the Wing Commander opened. "But I won't. You know what we are up against, and you know what is expected of you. That's all, gentlemen, and the best of luck."

They saluted again. True, some hesitated as if they wished to say something, but tradition and discipline tempered their emotions. They simply answered: "Thank you, Sir!" and moved off.

Evans turned to Kirk, and the expression on his face proved he was profoundly touched. He flicked a tear from the corner of his eye.

"Craziest people in the world, you Britishers," commented Kirk, likewise affected. Just take orders, keep their traps shut—and go out and probably get killed. How do you do it?"

"You should talk," cracked Evans. "They have to do it. While in this case, you don't. But you've been in the thick of it for hours—and still you want to go along."

"Why not? I owe those raider devils plenty. This is a personal battle with me, and I don't quit until I've cleaned the lot out."

"A very laudatory objective, my lad," agreed Evans moving over toward the lead Breda. "And now how do you like our insignia?"

Then for the first time Kirk noticed that the scarlet discs of Nippon had been quickly but skillfully changed to a familiar outline—the outline of a British Mark II.B tank superimposed by the head of a gorilla.

"Great!" smiled Kirk. "I suppose that is your way of paying a compliment to my pal, Tank?"

"Exactly! And if these Mussolini busses stand up like your—er—your gentleman's gentleman, then we should put up quite a showing."

"In response," added Kirk with a courtly bow, "I'll tag my particular Breda with the title of 'Betsy.' Agreeable to you?"

"Perfect! I had a maiden aunt named 'Betsy.' She was a howler! Once she pulled a letter box up out of the pavement just because she received a birthday card a day late!" Lovely soul, old Aunt Betsy."

"Let's shove off before we go 'relations' on each other," laughed Kirk. "Else we'll never blow the old *Akudo*

out of the water. Best of luck, Evans, old lad."

They shook hands, exchanged glances, and headed for their respective machines.

"Nevertheless I hope I get back to hear further episodes from the adventures of Aunt Betsy," Kirk muttered.

THE BREDAS were ordered into two flights of ten ships each. One flock was led by a young, thin-faced Squadron-Leader named Cliff, the other by Kirk, with Tank in the rear office, as usual. Wing-Commander Evans took the Fiat bomber as his flagship and planned to maintain touch with both flights *via* radio.

Twenty-one to take on at least forty high speed single-seaters that were well armed and flown by pilots who were charged with the fanatic patriotism engendered by promises of a new Oriental Empire! Even so, the Bredas were manned by highly skilled crews and carried a vast amount of worthy armament. In addition, all these planes carried twelve light bombs suitable for an attack on the flight deck of the *Akudo*. And Evans' Fiat was equipped with British delayed-fuse bombs for attacks on the deck of the enemy aircraft carrier—bombs that would pierce the teak and metal landing deck and hurtle on through to the more vulnerable compartments below before exploding.

The take-off was as imposing a display as could be imagined. The big Fiat hammered down the parched turf first and hoiked into the air under the skilled hands of the Wing-Commander with a young Flying Officer, Lewis, at his side. Up front, a pink-cheeked Limey gunner, hardly in his teens, peered anxiously out of the shatter-proof glass turret and gave a feeble wave to a couple of pals at the wing-tips. There was another officer in the avigation compartment and a radio operator behind the control pit. Still another gunner, who might have been a twin to the one up front, fumbled with the Breda-Safats in the rear turret.

The Bredas took off in chain formation, zoomed at the end of the runway, and hammered for altitude. They swung into position over the city, and Kirk saw several cheering signals flash up from the entrance steps of the Governor's mansion as they turned in glorious grouping and headed up the coast toward Lubuk Bay.

Finally, they swung off for Pindassan and cut around the mountains past Jesselton, the actual capitol of North Borneo.

Since their return after taking over the Bredas in the jungle hide-out, Wing-Commander Evans had made a more careful study of the papers procured by Tank, and, with the Squadron interpreter officer, had further learned the general plan of the proposed attack. They knew now that the *Akudo* planned to appear suddenly off Brunei Bay—about thirty miles southwest of Jesselton—then ease into the sheltered waters and stage their proposed landing of marines, light field guns, and supplies while their planes bombed Brunei, Jesselton, and if necessary, Lubuk and

Sandakan.

Evans, flying high, up front, led the way out to sea once they had studied the situation around Jesselton.

"He's making all the right moves," reflected Kirk, when he saw the Englishman lead them out over the ocean. "If we can come up from behind we'll have all the advantage. But, Lord, what a night this is going to be if we do clash with them!"

They flew almost due west for nearly thirty minutes. Then Evans gave a signal and reported that he was going down low in an effort to search the surface below. The two flight leaders repeated his signal and headed on toward Brunei Bay, holding their altitude at about 6,000 feet.

The next fifteen minutes were grim, spine-tickling, and eerie. The twenty fighters carrying the Tank insignia opened their formation slightly to cover a greater area and to play safe. Kirk watched the moves of Cliff, the No. 1 Flight leader, and then caught a signal in his helmet phones.

A report from Evans!

"Tank squadron," came the words. "Prepare for action at point due north of Barum. Have spotted enemy fleet approximately six miles off Barum Point."

Kirk glanced at his map in the clips and saw that the spot designated was but a few miles south-west of Brunei.

The speaker phones crackled again and he caught:

"Flight One: Action on target, half left. Enemy planes leaving flight deck of Akudo. Form echelon for attack. Flight Two: Maintain altitude until further orders. Leaders repeat signal—Evans."

In turn, Cliff and Kirk repeated Evans' signal, and then Kirk saw Cliff's outfit swing into echelon formation and go down. At first Coffin had no idea what they were heading for. But as the first flight went down he followed their tail lights and then caught the gleam of a long spear-shaped platform ahead and below—not four miles away. The Japs had illuminated their flight-deck, a move displaying total ignorance of the threat above—and which betrayed them to the Breda formations above. Or were they really ignorant . . . ?

"They're getting those ships off fast, though," sensed Kirk. "They're buzzing off like flies. I hope young Cliff can beat them down so that we can get that plane-loaded baby."

From that instant on the world went mad!

The first flight of Bredas flew smack into a curtain barrage of 3-inch anti-aircraft stuff that threw a "Hell's Ar-bor" of flame-shot rosettes against the ebon night. Kirk saw the flight under young Cliff slam headlong into this Design of Death. Two searchlight beams sworded into the night and slashed the sky savagely.

"Good Lord! They must have known after all! They must have been tipped off somehow. Those poor devils slammed right into a beautiful trap!"

Three Bredas blew up before they were within range either of the flight deck or the Jap fighters that were

streaming off the carrier like wasps. Flame, smoke, and flickering sections of bright dural added to the crazy back-drop of Doom.

"Their microphone men had the decibel rating of those motors down to the last tick," snarled Kirk. "Those poor fellows were trapped the instant they started down!"

"Go into action, Flight Two!" bawled Evans from somewhere below. "Action—fast!"

Kirk repeated the order, then barked it back to the men in his flight.

"Follow me," he ordered. "We're going down to zero level. They have us spotted this way. So we're going down low and attack from their deck-line level. Repeat!"

A babble of voices came back to him, but it was obvious they had caught the order. Behind, Tank was yanking out the guns in preparation for the battle that they were heading into.

"Only fire at that!" ordered Kirk, pointing down at the carrier. "Only that ship, Tank!"

He wanted no trouble with the ape, who might mistake the Bredas for the Jap Mitsubishi planes. If he confined his efforts to the carrier, he could do no harm to the Britishers.

The flight under Kirk's command followed him down in perfect formation. With the gray-green waves rushing up toward him, Kirk pulled out, nosed around, and headed straight for the Akudo. From somewhere above, a trio of Rising Sun ships slammed at them and sprayed the sky with lead. But Kirk kept on, sensing that the gunners in the Bredas behind him would hold them off.

He tightened his belt, adjusted the buckles of his life-jacket provided by Evans—and headed dead for the carrier!

"IT'S now or never," he growled. "If that vessel gets into the bay we'll never stop them. They'll call for a destroyer fleet and take over like Grant took Richmond."

The Bredas fell in line-astern now on his order, and together they hammered at the knife prow of the Akudo that was still spewing Mitsubishis.

Kirk fingered for the bomb releases and held the Breda dead on the nose of the carrier. He gulped, wondering whether he would make it. But he hung on as the nose of the Jap carrier came on at express speed.

"Good Lord!" he gasped, as a low-wing fighter flipped off the deck and screamed a hair's breadth over his hatchway.

There was a resounding crash behind as the Jap fighter collided head-on with the Breda following him. Kirk did not look back, but his mind's eye developed a picture of the wreckage of two planes being run down by a massive carrier that was doing about thirty knots. He winced at that—and pulled his releases!

The Breda jerked as the bombs slipped out of internal racks. He hoiked hard to clear another Mitsubishi that was pounding down the deck. He jerked the releases again and let the rest of the "eggs" go full on the deck.

Balsa Wood STICKS SHEETS BLOCKS SAW-CUT Propellers

MANUFACTURERS!—DEALERS—JOBBER

CLUBS—SCHOOLS—EXPORT

SELLEY again has perfected an entirely new and fast method of cutting balsa, enabling us to produce in 1 hour what ordinarily would require 6 hours to do. Hence, this saving in labor cost is passed on to you at these **NEW SENSATIONALLY LOW PRICES**. Our Saw Cut Balsa propellers are the finest cut and most accurate true pitched propellers available. We are prepared to furnish sizes from 5" to 19" in any quantity on short notice.

And now, an unfailing, reliable source for the best selected grade of the **MOST ACCURATE AND SMOOTH CUT** sheets, sticks and saw cut propellers at surprisingly **NEW LOW PRICES**.

NEW!—Just off the PRESS

Confidential NET PRICE LIST

Every dealer will find this the **MOST COMPLETE LIST** ever compiled for the Model Industry, all basic and Raw Materials, Special Wood Parts, Wheels, Die-Cast, Airplane and Boat items, Boxwood Parts, Dope, Rubber, Paper, in fact, hundreds of items that can now be supplied from one source at the **Lowest possible Prices**.

WE GUARANTEE complete satisfaction, service. Our reputation is for High-Class Workmanship and the Finest Quality in Model Products.

IMPORTANT—We will mail this list to legitimate dealers only. Use your letter head. Post cards positively will not be acknowledged. Before placing your next order, write for our price list and see our prices before ordering.

SELLEY MANUFACTURING COMPANY, Inc.
Dept. 104 1377 Gates Avenue, Brooklyn, N. Y.

Big PAY in AVIATION

Be a Transport Pilot, an Airplane Mechanic or Aeronautical Engineer! Aviation pays Pilots up to \$6000 a year! Airplane Mechanics also get good pay! You can train at this **LINCOLN GOVERNMENT APPROVED SCHOOL** for a good-pay position in Aviation. Train here on fast modern airplanes; repair and overhaul aircraft motors; help design and build real airplanes. We teach you how and assist Graduates in locating positions. Part-time employment for board and room while training. **WRITE TODAY** for complete information.

LINCOLN AIRPLANE & FLYING SCHOOL
3529 Aircraft Bldg. Lincoln, Nebraska

See WOODSTOCK TYPEWRITERS

AIRPLANE CEMENT

	AAA	No. 1	Regular
1 oz.	10c	7c	5c
2 oz.	15c	10c	8c
1/2 pt.	25c	20c	15c
1 qt.	45c	35c	25c
1 pt.	75c	60c	50c

Dealers: Get our prices on tubes and cement. Fill your own tubes. Add 15c postage up to \$1.30; 10% over \$1.50. No orders less than 50c.

QUALITY CEMENT COMPANY
4337 NO. TROY ST., CHICAGO, ILL.

COLT 45 CAL. Frontier Model

Basewood construction kit with working plans and all necessary hardware. Barrel and cylinder are machined.

COLT 45 Cal. "FRONTIER" model kit, \$1.45
1 1/2" barrel "FRONTIER" model kit, \$1.85
COLT 45 Cal. "FRONTIER" model kit, \$1.70
COLT 45 Automatic Pistol kit, \$1.00
THOMPSON SUB MACHINE GUN model kit, .50
COLT 25 Cal. automatic pistol kit, .50 \$3.00
Savage Cal. 32 automatic pistol kit, .75
LUGER 9 M/M auto. pistol kit w/4" barrel, 1.75
LUGER 9 M/M auto. pistol kit w/5" barrel, 1.90

All kits make beautiful full scale models.
Postpaid in U. S. A.
GUN MODEL CO.
Dept. F64, 2908 N. Nordica Ave., Chicago, Ill.

Modelbuilder's Super Catalog!

You'd spend scores of hours and many, many dollars if you wrote to all the concerns whose products are now shown in this one big book!

The C-D Catalog No. 6 is a regular handbook of Kits, supplies and materials. Bargains galore. Everything for all kinds of modelbuilders—and for all purses. Greatest lineup of flying, solid and gas powered airplanes ever presented in one book—and that's only the beginning. There are gas motors, gas engines; Kits for: Model RR (O, CD, OO and HO-Gauge); model ships, model auto race, model speedboat, Candid and movie cameras and projectors, telescopes, microscopes, home workshop equipment. And of course everything imaginable in parts, materials and supplies. Wide variety of tiny electric motors, and other very hard-to-get hardware items. Don't be without this super catalog. Rush your name, address and 10c for your copy at once—NOW!

THE CLEVELAND MODEL & SUPPLY CO., INC.
4508-C17 Lorain Ave., Cleveland, Ohio, U.S.A.

A portion of the carrier's "island" superstructure then toppled across the deck and floundered across the last three Mitsubishi fighters waiting to get away.

CR-R-R-UMP! BR-R-R-R-UM!

Flame, smoke, and concussion battered at Kirk as he slewed off to starboard. He turned and saw Tank sending a wild burst of fire down at a group of bluejackets huddled about a 3-incher. A light flashed out and blinded him for a moment, but he cleared and danced in the concussion of a burst of anti-aircraft fire that fanged out from a hidden turret below the battered flight-deck.

The remaining Bredas of his flight followed him and rained their explosives down upon the teak and steel deck, then skudded through the welter of flame and debris each bomb threw up. One Breda ran smack into the lip of the carrier deck and scattered its parts all over the flight deck. Flame billowed out and Kirk knew another brave British crew had gone west.

But by now the Jap pilots were in action against the raiding Bredas. Off to

the right, young Cliff was weaving his flight—or what was left of it—in and out of a Mitsubishi formation. The gunners were fighting like Waterloo heroes from their rear turrets, and the British pilots were hammering heavy caliber stuff at the dancing single seaters.

The sky was a mad theater of tumbling fire-balls. Bredas and Mitsubishi fighters locked wings, rammed noses, and slithered into each other from all angles.

Kirk led his mob into it all and gave signals calmly as he slapped short but deadly bursts at the Jap single-seaters. Tank, dancing his jungle war hop, still blazed away madly at the indistinct carrier from which sizzling 3-inch shells continued to blaze.

"Where's Evans and his Big Berthas?" raged Kirk: "Where the devil is that bird?"

Now the American rammed through a scattering formation of Mitsubishi fighters and sought the Fiat. His guns splashed lead at a Jap directly in his path and blew it to bits. He darted clear

of the debris and banked to avoid three attacking Mitsubishis. Two Britons in Bredas somewhere above picked two more Japs off, sending one down in flames and ripping the wings off another. A third Nipponese hoiked so hard he flamed up dead into the path of another and they both went down in a swirl of smoke and flames.

Then, out of the corner of his eye, Kirk caught the outline of the Wing-Commander's Fiat. It was fighting its way through a veritable wall of Mitsubishis. Kirk changed his course, barked a crisp order into his phone, and went to the rescue. Number Two Flight slammed at the heavy formation of Mitsubishi fighters, sprayed it with Italian lead, and broke it up.

A report then came through from the Fiat, and Kirk slammed at the Japs again—keeping them in the clear until Evans could get set for his personal raid.

Kirk saw Evans dive for the carrier and then saw three more Bredas kick out of nowhere and blast at the deck, too. It was obvious that they were still trying to get at the carrier deck with what bombs they had left.

"Look out!" screamed Kirk. But the Breda guys were intent on doing what they came to do. They slammed full at the *Akudo* and released everything they had left amid a welter of anti-aircraft fire and the blinding glare of a lone searchlight that was picking out the raiders.

Kirk saw them hoik up and saw the first blast of flame from their bombs. Then, as the *Akudo* belched forth a mass of searing flame, the Fiat flew into the middle of the lot just in time to take the full force of a massive explosion.

"Wow!" gasped Kirk. "One of those Bredas put a bomb through that caught their magazine!"

BRRR-R-R-OOOM!

The decking of the carrier suddenly blew out and engulfed the Fiat which had roared in to lose its heavy armor-piercing stuff.

The great carrier's blazing maw now spewed gigantic blossom of scarlet flame. Great forks of fire flashed out, pierced the Fiat—and hurled it over the side of the still speeding hull!

"Lord!" Kirk raged. "He flew right into it. What the—"

He himself now cleared the doomed hulk and saw men leaping into the sea. He tried to glance down and see where the Fiat had hit, but the blinding glare of flame and the mushrooming smoke blotted out all vision of the water below.

"Poor old Evans—and not a boat anywhere."

He roared past again and drew his wing men with him as Cliff rounded up his formation to chase the fleeing Mitsubishi fighters. There was now no carrier deck left, and it was obvious that the Nippon planes left in the air must scurry off.

THEN, before his startled eyes, appeared the most beautiful formation Kirk had ever seen. Six majestic flying boats, glinting in steel gray, and gay with red, white, and blue cocardes came

A "BUCK"

Will Bring You a Whole Year's Subscription To

FLYING ACES

Greatest of Aero Mags

Yes, a year's subscription means 12 copies—one each month for a whole year! If bought singly they'd cost you \$1.80. If bought one subscription at a time they'd cost you \$1.50. But if you'll just get two other fellows to join you in subscribing at the same time (three in all) you and your two friends will have your subscriptions for only a dollar apiece!

YOU ARE SAVING REAL MONEY

when you snap up this swell offer. Why, think of the models and materials you can buy with this surplus cash! And all you have to do is to get two of your pals to go along with you. Each pays a dollar—that's \$3.00 in all—and your favorite magazine, FLYING ACES, will be mailed to each of you for a whole year, starting with our very next number.

Subscription Dept. 49, FLYING ACES
67 West 44th St., New York, N. Y.

Gentlemen:

Enclosed is \$3.00 for which you are to enter a whole year's subscription to FLYING ACES for each of the three fellows whose names are written below. This is in accordance with your special offer. My name is the first on the list.

Name

Street and No.

City and State

Name

Street and No.

City and State

Name

Street and No.

City and State

TAKE ADVANTAGE

of this chance to save NOW. Special offers like this—meaning extra cash in your pocket—don't come along every day. So get busy and let's hear from you right away. Just use the accompanying order form.

This offer is good only in the United States and possessions. It does not include the F.A.C. Ring or Bracelet.

roaring over!

"Cripes, the Navy—our Navy!" gulped Kirk. "What the devil! Who called 'em?"

He caught the identification numerals on the sides of the hulls and saw them go down to the water, great landing lights laying broad pathways for them. He realized that they were Consolidated PB3Y-1 patrol boats out of Manila. They had made the 750-mile flight that afternoon. The Philippine Navy radio somehow had caught the faint sparks of warning sent out of Sandakan. And these planes had hastily flown south.

All this flashed through Kirk's mind as he watched a long silver pencil of light from the blunt nose of a Consolidated pierce the smoke and flame to pick out a floundering Fiat. That beam showed Evans standing on the roof of the cabin and waving—of all things—a handkerchief!

"Oh, well. Let the Navy clean up. They always do," muttered Kirk. "I'll take my lads home—what's left of them, at any rate."

He did, and later watched the battle-weary R.A.F. pilots crawl out of their planes at Sandakan and stagger off toward the medical hut. Kirk and Tank then rolled up to the "A" Flight hangar and asked that their tanks be filled.

Finally, the American went in to Evans' recording office. Here he conversed with the Adjutant and told him what had happened. Then, while the adjutant hurried off to get a short message through to Singapore, Kirk sat down and scrawled a note. He stuck it

GET ACQUAINTED WITH SKYWAY!

FREE with all purchases over \$1.00 your choice of: (1) Model Water Sprayer, (2) Model Builder's Knife, (3) Choice of 2-20" Model Planes—Curtis, Heath, Boeing, Driggs.

18" Balsa Planks 1/2x2 2 for 5c 1x1 1 for 5c 1x2 1 for 8c 2x2 1 for 22c 2x6 1 for 38c 3x6 1 for 72c NOSE BLOCKS 1x2x1 1c 2x2x1 2c 2x2 1/2x1 3c 3x3x1 4c 3x3x2 7c 3x3x3 10c 5x5x2 25c 18" Balsa 1/16x1/16 100, 5c 1/16x3/16 35 for 5c 1/16x3/16 18, 5c 1/16x3/16 15 for 5c 3/32x3/32 30, 5c 3/32x1/2 30 for 5c 3/32x1/2 12 for 5c 3/8x3/8 16 for 5c 3/16x3/16 8, 5c 3/8x1/2 6 for 5c 3/4x1/2 3 for 5c 18" Balsa Sheets 1/64x2 6 for 10c 1/32x2 9 for 10c 1/16x2 8 for 10c	3/32x2 7 for 10c 3/8x2 6 for 10c 3/16x2 3 for 8c 3/8x2 3 for 9c 3/2x2 2 for 11c 3" sheets or 36" lengths, double the price; add 10c packing charge for 36" lengths. PROP. BLOCKS 1/2x 3/4x 5 7-3c 1/2x 3/4x 6 6-5c 5/8x1 x 8 3-5c 3/4x1 1/2x10 2-6c 3/4x1 1/2x12 3c ea. 1 x1 1/2x12 6c ea. 1 x1 1/2x15 6c ea. WHEELS per pr. Borch Balsa Cell 1/2 .01 .03 .05 3/4 .02 .04 .05 1 .03 .05 .07 1 1/4 .04 .07 .10 1 3/4 .06 .10 .16 2 .08 .12 .18 3 .10 .15 .30 Alum. Tubing 1/16 1 1/2 .6c ft. 3/32 1 1/2 .7c ft. 3/16 1 1/2 .9c ft.	PROPELLERS Balsa Paul-O-Mach. Cut Wina 5" 2c 7c 7" 3c 9c 7" 4c 12c 8" 4c 15c 9" 5c 19c 10" 6c 23c 12" 8c 28c 13" 12c 40c 13" X 40c 16" 15c 40c ALUM. WHEELS 1" pr.6c 1 1/2" pr.9c 1 3/4" pr. 1.2c Sheet Aluminum 10" x 30. ft. 10c ALUM. LEAF 5 Sheets for 5c TISSUE, AA All col., doz. 19c Silver 4c Superfine, wh. 5c CAMEL'S HAIR BRUSHES Small 3c; med. 5c Large 8c Wood Veneer 20x30" .1 for 9c 2 for 17c	BAMBOO PAPER White ... 5c ea. Colors ... 2 for 15c 11 in. BAMBOO 1/16x3/4 6 for 3c Shredded 40-3c Read—for 3c: 1/32 10 ft. 1/4 6 ft. 1/16 8 ft. 1/4 3 ft. CEMENT CLEAR DOPE THINNER 1 oz. 5c, 1/2 pt. 30c 2 oz. 9c, pint 50c Colored Dope 1 oz. 6c, 2 oz. 11c 1/2 pt. 35c. SHEET CELLULOSE 2x2-2c 5x7-4c 14x17 15c MICROFILM RUBBER LUBE WOOD FILLER 1 oz. 9c, 2 oz. 15c RITZ GAS PROPS 10" 40c 12, 13, 14, 15, and 16 in. 50c 18" \$1.00 Gas Model Silk per yard 40c	CONDENSERS each 25c BROWN RUB. 1/16 sq. 15 ft. 5c 3/16 flat 15 ft. 5c 3/16 flat 12 ft. 5c Skein 225 ft. 70c 5 FOOT BALSAs 7/8x3/16 15 20c 3/4x3/16 10 20c 3/16x3/16 8 20c 3/4x3/4 6 20c 3/4x1 3 20c 3/4x2 2 20c 3/4x3 2 20c Sheet costs 4 times 20c pack. charge on 5 ft. lengths DUMMY RAD. ENGINE (Cellu.) 1 1/2" dia.08 2" dia.12 2 1/2" dia.14 3" dia.17 NOSE PLUGS. 1 1/2" dia. 5c 3/4" 1 doz. 10c MODEL PINS Pkg. 100 1/2c	Gas Motors—P.P. Ohlsson 23 \$16.50 Gold Seal 18.50 Brown Jr D 10.00 Brown Jr B 21.50 Syntro Ace 9.95 M&M 17.50 Dennyrite 17.85 Dennyrite Stand 15.85 Bunch Midg. 9.50 CHAMPION SPARK PLUGS or 1/4" 60c ea. WIRE .014 6 ft. .2c .020 .028 6 ft. .3c .031 .040 6 ft. .6c 1/16" 3 ft. 5c 1/8" 5 ft. 25c PROP. SHAFTS Small .7 for 5c Large .4 for 5c AUSTIN FLIGHT TIMER 0-2 min. \$1.25 ea. SMITH IGNITION COIL each \$2.50 MODEL KNIFE Surgical steel blade 10c
--	--	--	---	--	--

Send 3c stamp for complete 1939 Catalogue
FREE POSTAGE ON ALL ORDERS IN U.S.A. Add 10c for packing cost on all orders. For U.S. possessions, Canada or foreign countries add 15% on orders over \$1.00; under \$1.00 add 15c.

SKYWAY MODEL AIRCRAFT SUPPLY CO.

383 Seventh Ave., Dept. F, Brooklyn, N. Y.

in an envelope and addressed it to Wing-Commander Evans.

It read:

Sorry not to be here on the welcoming committee, but we can't stand scenes. Hope you get your shirt dried out in time for the decoration that is sure to come. But we have other things to attend to, Tank and I. It has just occurred to me that we must track down those birds who flew the Bredas in. And so—we may meet again, on less exciting terms, I hope. Thanks for the memories, as the song goes—and lots of luck.

Brian "Coffin" Kirk—and Tank.

All Questions Answered

(Continued from page 26)

not say where they are, and no one seems to have seen them. Is it true they are not assembled but have been packed away in storage for quick assembly? Who can—or will—say? Also, they do not tell us how many are bombers, how many are fighters, and how many are Army or Navy types. So far, for instance, not one of the experts has stated what kind or type guns all these German planes carry. You have to select one person's story and believe it—or not believe any. As for me, I have my own opinions and ideas based on what facts are available—and not on estimated figures.

W. Jankowski, Chicago:—The Heinkel He. 51 is a fighter biplane fitted with the 750-h.p. B.M.W. engine. It has a top

speed of 206 m.p.h., a range of 445 miles, a wing-span of 36 feet, an overall length of 27 1/2 ft., and a height of 10 1/2 ft. Its full-up weight is 4,180 lbs. As for photographs used by this magazine, all are purchased for reproduction purposes alone. They cannot be sold or given away.

George Cole, Jersey City, N. J.:—The foreign magazines you mention can be purchased at the Shultz News Agency, at Sixth Avenue and 42nd. Street, New York City. You might write to the Sixth Fighter squadron, U. S. Naval Air Service, care Headquarters in Washington, D.C., for the details and information on their pilots.

BY ARCH WHITEHOUSE

Sky-Power Facts vs. Sky-Power Fancies

(Continued from page 55)

a capable mind that controls his reflexes and enables him to carry out the duties for which that particular aircraft was designed.

We must have trained pilots, super-trained observers, and gunners who can make the most of any target under the most trying conditions. Without men, our air service is much worse than obsolete. And the sooner this condition is seriously considered, the sooner American air power will attain its true im-

portance and become a weapon worthy of the land it is to defend.

Streamlined planes are beautiful to watch in maneuvers. Machine guns gleam and sparkle and have a certain blue-black air denoting power. The instrument boards are intricate and intriguing. Bombs have a sturdy mastiff scowl of authority. And the engines impress us with their potency.

But until the hand of a man is placed on the controls that guide the airplane,

GIVEN **Send No Money**



GIRLS! LADIES! BOYS! WATCH OR CASH COMMISSION
 Just Send Name and Address. Popular shaped chromium finished case and adjustable wrist band. Non-breakable crystal. Marvelous! This watch given for simply **GIVING AWAY FREE** big colored pictures with our famous **WHITE CLOVERNE SALVE** used for chaps, cuts, burns, sores, etc., which you easily sell to your friends at 25c a box (with picture **FREE**) and paying as explained in premium plan book. **SPECIAL**—Catalog shows twenty premiums for returning only 83 collected. We are fair and square. 44th year. Salve sold **most** every home. **BE FIRST!** Write quick for order of Salve and Picture sent. **POSTAGE PAID.**
WILSON CHEM. CO., INC., Dept. 120-35, Tyrone, Pa.

Life of the Party or Star of Stage and Radio

Learn to Play Rosati NEW IMPROVED Accordions

Want to be 'the life of the party'?— want to make big money as an accordionist with a band, on stage or radio?— use this amazing new Accordion. Easiest of all instruments to play, you can quickly learn jazz, swing or classics. Cathedral-toned with the famous Rosati quality reeds, beautifully designed, reasonably priced. You can buy it on liberal credit terms. Many dealers also feature a **COMBINATION PURCHASE and LESSON PLAN**. Write for **FREE CATALOG and name of nearest dealer.**

Gene Raymond is only one of the many famous screen stars who play the Rosati Accordion.

ROSATI
 42 E. 20th St., N. Y. C.

Please send me catalog 'F' and name of nearest Rosati dealer.

NAME _____
 ADDRESS _____
 CITY _____ STATE _____

the effective factor of the plane is zero!

Many new planes will be needed should an emergency arise. The normal wear and tear of active service flying takes a great toll. And aerial conflict, whether the engagement is won or lost, will deplete the flying equipment by at least 50 percent in the first six weeks of action.

America's real strength, then, lies in her *potential* man power. We believe there would be something like 25,000,000 persons available for active service duty if war comes within the next couple of years. A great percentage of these can be trained for air duty if a suitable selection system and pre-war training is established.

Man power? Yes, the United States

certainly has it—and it should not be wasted through neglect. Now is the time to begin some form of primary training—not after hostilities start.

That we have a splendid basic air force in the way of material has been shown. And the American system of mass manufacture, as far as it can be carried out in aircraft building, is as good if not better than any in the world. We should consider sound types of planes and eradicate the multiplicity of types in order to speed up production. Fortunately, this point has already been considered; for here in the United States we now find fewer types filling the service hangar than in any other major air power in the world.

In closing, we might repeat the fact

that our air strength is materially boosted by America's exceptional geographical position. But though the European and Oriental powers now have all they can handle in the way of trouble right in their own backyards, we cannot afford to rely on the Atlantic and Pacific oceans to set us off from them forever.

Already other big nations are building long-range bombers that can cross oceans, stage raids, and return. It is against this future menace that a great American air power—boasting plenty of good planes—should be established.

And with the present attendant inroads of dictator theories in South and Central America, that black future may be upon us long before we expect it.

“Attack Formations are Ticklish!”

(Continued from page 16)

at the beginning! The German then proceeded to lead us a merry chase for a couple of hours, “attacking” trains, highways, and bridges, sometimes in column and sometimes in normal squadron formation. His final surprise was a sham raid on a wealthy rancher's private airport up in the hills—and that was where we almost came to grief.

After we crossed the airport, a small hill appeared beyond. We “climbed” it all right, but at the top the German decided to turn—not *away* from the other planes, but *toward* them. And worst of all, he continued to climb as he turned.

In the “meat element,” we all cut our throttles instantly—for even the wing men could see what was happening. But the immediate effect of cutting an airplane's throttle is very slight, and at that embarrassing moment we seemed to lose no speed at all. I saw my element leader stiffen his neck for a brief instant as he tried to determine the proper reaction. And that brief moment of thought probably saved us, because if we'd tried to dive under the planes crossing our path we would have crashed into the hill beneath.

What's more, if we'd tried to turn and pass to the rear of Fluger, we would have collided with his wing-men, who were lagging a little. And if our element leader had pulled up suddenly—as any pilot is likely to do in a moment of surprise—we would have climbed into the third element which was hovering just over our shoulders.

Instead, our element leader turned as the German turned and managed to reduce speed enough to keep the nose of the German's plane in sight as he skidded across just above his tail, thus prolonging the suspense—and also prolonging the lives and usefulness of the pilots and airplanes.

BUT THE RESULT was *still* in doubt! I saw our element leader's tilted wing passing just above the upper wing of the German's plane. The German, meantime, was looking at the hill-top beneath and was blissfully unaware of the predicament he had caused. But our element leader luckily was peering over the side and trying to gauge our

distance above the first element as closely as possible before these lead planes disappeared into our blind spot underneath.

Now we were all climbing steeply. And at last I was sure that we “meat element” boys were outclimbing the first element. But what about the third element? It had also been cut-off on the inside of the turn and would have to climb over all the rest of us!

Our element leader glanced back at them—and I saw a frightened look come into his eyes. Whether they would miss us or not, nobody knew. But I was on the inside! I would be the first to find out!

Although I dared not shift my attention from my own leader, I stole a glance backward—and my heart stopped beating! The third element was only a few short yards to one side, turning sharply but sliding toward me, and on the same level! Trying to slow down enough to keep us in sight as they crossed-over, they had lost more speed than they could do without and were about to stall right into us!

I had about two seconds to go. Looking toward my element leader again, I could no longer see the first element beneath us. Maybe they were still there, or maybe we had already crossed them. But at least their chances were better than mine; for the third element had already slowed down, climbed, and turned as sharply as it could. Yet *still* it was coming toward us!

Suddenly, I heard above the sound of my own engine, the roar of another. It was so close that I thought I could feel the propeller beating the air just above my head. Every muscle in me stiffened with fear, but I managed to push forward just a little on the stick . . .

It is most annoying for a man's conscience to bother him at such a time. But mine did. I couldn't help thinking about the first element wing-man who might be beneath me. Even so, a fellow can also think of an excuse in a split second, and mine was that if I was hit I would drop on him anyway—which was true.

. . . But what a relief! The roar of a wide-open engine swept over my head and was gone! My leader began to

straighten from his turn, and as he did so he noted my slightly lower position. A look of angry surprise and a jerk of his head indicated that I had better pull up and look on the other side in pronto fashion.

I did both at the same time. And I saw my lower wing rising from somewhere very near—entirely *too* near—the cockpit of another plane. The pilot was sitting upright, so I knew that my wing-tip had not struck him. But I felt like a man caught in the act of shooting someone in the back—for he had never seen me at all.

In another instant, I was back in position and my heart was trying to make up for lost beats. Quickly, I counted nine planes. What a relief. Nobody lost! We had crossed above the first element and dropped beyond and beside it as the third element stalled toward us. They had opened their throttles just in time to hold altitude and miss our heads as they passed over.

I felt numb and weak. My left leg began to vibrate against the rudder pedal so helplessly that I had to laugh. It was the first time I got so badly frightened that I quivered afterward, and it was all because I had too little faith in the leader of the third element.

“Say, what's the idea?” he cracked at me after we landed. Don't you know I'm not going to hit you? All you have to do is stay in place.”

I was ashamed of myself. And mighty sad, too, I might add, when seven months later he lost his flying speed—and his life—trying to hold position on the inside of a climbing turn at low altitude.

FOR an Attack pilot, the unpardonable sin is a variation of altitude during a maneuver in formation. Leaders who sometimes climb on their turns are disliked by other pilots, and those who seem to forget the men behind them are dreaded.

After this particular experience with the German, our formation often failed to keep as flat as it might have been while he was doing the leading. And meanwhile we all longed to get out of the school and into a good tactical squadron where we could fly more safely

with leaders of long experience in Attack work. Even with the best of flight and element leaders, embarrassing moments are bound to occur. But actual collisions in the air are remarkably rare among experienced pilots.

After you get used to it, you don't mind flying flat Attack formations—as

long as you know the men who are with you. When a wing-man of the third element tells you that his leader grazed your head during an unexpected turn, you say "Oh, that's all right. Close shaves do happen every once in a while—but he's never hit me yet."

And the chances are he never will!

If the "New Caesar" Raids "Carthage"

(Continued from page 17)

the Maginot Line has been constructed in the south (near the Libyan border) and is kept manned at all time. This is called the Mareth Line.

THE PRESENT DISPUTE over Tunisia began back in 1869 after the French occupation. Financial troubles in Tunis proper resulted in a British-French-Italian board of control which eventually resulted in the territory becoming a French protectorate in 1881. There was simply the usual border "incident" and the French marched in. British opinion backed the move, but Italy protested at the time. Then in 1896, Italy officially recognized the French acquisition.

As the years went by, the number of Italian residents in Tunisia increased. In 1935, the French agreed to allow the Italians living there to maintain their Italian citizenship and own their own schools—which of course resulted in Fascist instruction, plus propaganda in favor of a transfer of sovereignty. About 80 per cent of the "New Carthage" Italians are Fascists, and they have a common leader in the very active M. Santamaria, a newspaper editor.

On the strength of all this, then, Italy feels that the time is now ripe for occupation. And they've "talked it up" in no uncertain terms. To forestall action, the French quickly put over a diplomatic gesture in which Premier Edouard Daladier made an official visit to Tunisia and won the formal declaration of loyalty from the Tunisians. But this move was dubbed an "act of provocation" by the Italians, thus anything may now result.

So it would not be surprising if Italy—eager for more area in which to expand, more fertile lands on which to grow food for an increasing population, and for continued maintenance of the "New Roman Empire" military policy—unleashes an air attack on the site of old Carthage.

In these days of undeclared war, an air attack is the ideal means of opening

a campaign. Such a blow can be delivered with speed and power. And it costs little compared with a major attack involving troop transports and surface-fleet action.

What would be more reasonable than to assume that Italy, in its drive to capture Tunisia, will use its air arm as a "feeler" to find out how much strength there is in the French colony, and whether all the arms and armament supposed to be there are *actually* there?

OUR ARTIST has presented on this month's cover, his idea of what an Italo-French sky skirmish over Carthaginian Tunis might be like. He depicts a fast-action dog-fight between two groups of ultra-modern single-seat fighters. It is assumed here that the Italians have launched their raid from a secret air base in Sicily, employing a formation of sleek single-place Bergamaschi A.P.1 attack-fighter monoplanes, a new type recently accepted in the Italian Air Service.

These planes, especially designed for low-altitude duty, have a top speed of about 217 m.p.h. They carry three machine guns for ground-strafting, plus a special bomb rack inside the fuselage. The bomb-sight aperture is covered with a series of rolling shutters set in the floor.

The French pursuits we show on defense are new Morane M.406's—reported capable of startling performances (see zooming Morane in foreground of scene). They carry an air cannon in their Hispano 12Y engines, also two ordinary machine guns. Their top speed is 310 m.p.h.

Here, then, are all the elements of a rare battle as the Italians attack the ground points and the Moranes fight to repulse them with high speed performance and high caliber lead.

Could the air fleet of the "new Caesar" be victorious—or would French "Carthage" turn back the Roman invader? That is the question. And we may not have to wait long for an answer.

Slaked Limeys

(Continued from page 12)

topkick, was concerned. But Boyles-Ryce finally began to complain of a terrible disturbance in his mid-section. Then another Limey Camel driver got as green as turtle soup and staggered out to gulp at the fresh air, and two more pilots lost interest in the war and called for double-quick first aid. Major Fyer-Sayles felt a little gaga himself and weaved an uncertain path back to

his sanctum. After swallowing three pills, he sat down heavily to think things over.

"Blarst it! Not the pot," he muttered. "An' not the bloomin' tea. Jolly well stumped! Cawn't imagine—pot—water—water—? Gad! Something in the well, no doubt. Cawn't empty the blarsted thing—cawn't—!" The Major got up and went out into the mess kitchen. The

GIANT SUPER MAINLINER
42 PASSENGER PLANE 26" WINGSPAN



ONLY 50¢

BOATS
TRAINS
MOTORS
ENGINES
CHARTS
GUIDES

The United Air Lines New Giant. A new type easy to build kit, exactly scaled—21" wing span—18" fuselage. Kit contains printed Balsa and Veneer sheets, ioneron skins, blocks for nose, tail and coving. Also rib jig, glue, aluminum props, insulators in correct colors for name, license numbers, etc. Full size plans and instructions, 50c, postage 10c. This same Kit complete with 4 chrome plated—exact scale—3 bladed propellers. (The type used by the airplane companies in their own models.) \$1.00, postage 10c.

THE SHARPIES—Designed for model builders. A pair of permanent, keen, double-edged knives in protective fountain pen type handles and covers. No extra blades to buy. Cannot slip out while working. In 2 sizes—**one for work on Balsa and light woods or materials, and No. 2 for cutting and carving heavier woods, leather, tinolium, etc.**—20c per set of 2 (add 10c to cover cost of postage and packing). Send 10c for complete catalogue.

International Models (Dept. F) 251 W. 55th St., N. Y. C.

"HI, BUTCH! IF YOU WANT AN AIRPLANE LIKE THIS, SEND A DIME FOR HAWK'S CATALOG!"



New 1939 24-page Hawk Model Catalog now ready, showing the latest complete scale model airplane and railroad kit attractively priced. 1/2" scale solid models. Parts and supplies available.

HAWK MODEL CO. 3521 West Fullerton Avenue Chicago, Illinois Dept. F. 49

Spectacular Sale Stock Up Now While Liquid Prices Are At The Lowest Point in History.

COMPARE OUR PRICES

Send 5c For Completely Detailed Price List. Because of Bargain Prices We Cannot Pay Postage. Kindly Remit With Order.

Cement, Clear Done Thinner, Rub. Lub. 1 Qt. 58c
1/2 Pt. 20c, 1 Pt. 36c
5 Gals. \$5.95, 1 Bhl. \$37.50

DE LAND AIRWAYS
57-58 Whitehall St. N. Y. C. N. Y.

STUDENT FLYERS OF AMERICA, INC.

Expert flying instruction by Gov. approved instructors. New flying equipment. Ideal planes for winter flying. Free Ground School. Comfortable club room. Excellent airport. Cost within the reach of everyone. No down payment. No obligation to continue. Credit extended. Opportunities to earn expenses. Write for FREE interesting pamphlet No. 6.

Hangar No. 3, Floyd Bennett Field, Brooklyn, N.Y.

If You Take Pictures--
don't miss the April issue of

EVERYDAY PHOTOGRAPHY MAGAZINE

This issue is packed with interesting and helpful articles written by experts for the amateur picture-taker. In addition there are special departments on every interesting phase of photography. Special features in the April issue include:

WHAT MAKES A PRIZE PICTURE?
by Karl Barleben, F.R.P.S.

PHOTOS, THE PERFECT GIFT
by Mario and Mabel Scacheri
TAKE THEM IN SERIES!
by Jacob Deschin

THE TRICK OF HUMAN INTEREST
by Victor De Palma
and many others

Plus prize pictures—kamera kinks—newest ideas and a wealth of other new and interesting information.

EVERYDAY PHOTOGRAPHY MAGAZINE
15c At Newsstands Everywhere

water pail had been emptied so he hot-footed it out to the well. There he saw two pilots drawing up a bucketful of water.

"We let the bucket down deep, sir," one said to his superior. "If hanything fell into the well, we 'ope to find a trace—"

A Limey pilot played a flashlight on the bucket of water. "'Ullo! By jove, Major!" He lifted something off the top of the bucket, a strip of colored paper. Holding it up to the light, he read: "*Ropo-Stinko*. Odd name, eh, what?" He looked more closely: "*Cigars That Go Boom*. *Kid-Ribber Novelty Company*. Five cents each."

"Strike me pink!" broke in Major Fyer-Sayles. He drew himself up in high dudgeon. His jowls inflated and quivered like a wind sock. "Tobacco juice! That's what! In the bloomin', blinkin' tea. Quite filthy, an' all that. Frightful joke, don't you think? Find the chap—spread him to a gun carriage. Shoot 'im!"

"I know the bounder," Captain Boyles-Ryce said, after fighting off a swoon and wiping large beads of nausea dew from his face. "It's Lieutenant Pinkham of the Ninth Pursuit over at Bar-le-Duc, yes. Stood 'ere by the well this morning, he did that. Dropped in for a spot of petrol, though there was ample in 'is Spad. Gad!"

Major Fyer-Sayles got apoplectic again, fairly blew off steam. He strode to the Operations Office, promising dire punishment for the offending Yank. Muttering something about co-operation with the Spad outfit, he rang up the Old Man of the Ninth and reported the terrible act of sabotage.

"That's what I said, Garrity! Tobacco juice in the squadron's tea, no end! Four of my brave chappies unfit for service at the moment, Sir. Proof? Egad, man, you shall jolly well 'ave it! '*Ropo-Stinko*. *Cigars That Go Boom*.' Bah-h-h-h-h-h! I demand that Lieutenant Pinkham be put under arrest. Attempt to incapacitate British flying squadron, an' all that! Treason! Criminal assault, Major! The blinkin' bloomin' idiot. Shoot him!"

"With pleasure," Garrity roared. "I'll have him under arrest in just three minutes. Sorry, Major. In the tea, eh? Tobacco juice—that's bad, yes. The man's a menace to—" The Old Man broke off, hearing the Limey Major hang up on him. Then he bellowed for Phineas Pinkham.

When the Boonetown patriot got to the carpet, the Major casually asked him for a trick cigar. He wanted to fool a smart brass hat in Nancy, he said.

"I—er—I'm all out of 'em, Major," Phineas confessed. "Haw-w—er—I get it! Trappin' me, huh? Oh, don't try to stall! I know what you're up to. Awright, I fixed the Limeys tea wagon. They asked for it. Them bums!"

"Pinkham, you've got the Frog flyers making faces at us. Now the British are out to nail us. If we want to lick the Boche in this sector, we've got to have full co-operation from the other outfits. You're wrecking the works, you fan-eared imbecile! I promised that

Limey Major I'd have you arrested. If I don't, he'll go to Chaumont and demand—"

"Awright, arrest me!" Phineas said. "See if I care. Then somebody else will have to get von Frankenstein. Haw-w-w-w! You know how they'll decorate the outfit that gets that big hunk of weeny-wurst. The squadron will get decorated, an' Pershin' will come to shake hands with all the flyers and their C. O. Well, I had an idea how to get the bum, but I will forget it. I'm not appreciated. Bong swar to you, Major—"

"You're still in circulation, Pinkham!" the old man fairly screeched. "But you keep out of Bar-le-Duc and take your name off that Spad. That Limey won't know whether you're in the klink or not. If he finds out—and if I catch you aggravating those British flyers in any way again—I'll—I'll—"

"Oh, you wouldn't do that!" Phineas grinned, backing out. "You won't be sorry for such leniency, Sir. A Pinkham never forgets."

NOW over on the Limey drome there was terrific excitement. A visitor had arrived and strode into squadron headquarters. Thereupon, a batman ran into the quarters maintained by Captain



Ronald Boyles-Ryce and whispered excitedly into the flyer's ear.

"What, Muggins? You're pullin' my leg, Muggins!"

"I 'opes to drop dead, I do, Captin, if I ayn't givin' hit to yer str'ight, Sir. Yuss—hit's 'im!"

"Pip! Pip! Fetch my new boots, Muggins, 'op to it, old chap!"

The British Camel outfit was all agog. A little grease monkey came as close to the officers' mess as he dared and stared in the window. "Gor blimie, 'e's in there—lawks!"

The flight sergeant then sent his men scurrying about the drome to police up. Camels got extra inspection in the hangars. Batmen dressed up their flying gentlemen and sent them out of their quarters looking as if they were about to meet Mata Hari. Yes, the Camel drome had been highly honored. The tea outrage was forgotten.

PHINEAS PINKHAM spent most of that same night scheming in his hut. Bump Gillis complained that the noise of his thinking kept him awake, but Phineas only grinned and shoved his hutmate's head down under the blankets.

"A thousand dollars," he grinned. "I could use that nicely!" Getting Frankenstein for the Ninth was imperative, too, for the reputation of Garrity's fly-

ers had suffered at Chaumont during the past few weeks. Why it had been Brigadier Wofford of the British Army who had had to jump out of his motor car and capture a Jerry flyer carrying important information on his person. Von Frankenstein was going to be as hard to get as a six weeks furlough to Paree, Phineas admitted, but he had knocked off the other vons who were supposed to be immune to Yankee skullduggery. By midnight Phineas had it all figured out.

Aerial warfare was at a standstill for the best part of the next day. The sun did not dry up the soup in the sky until four in the afternoon. Phineas Pinkham went out with the dusk patrol and left Howell's flight over the back area. He circled in the ozone back of Metz, then dropped a corn syrup can weighted down with a chunk of iron. In it was a written defy to Baron von Frankenstein, the Munich Monster, the Scourge of the Skies.

That night Phineas sneaked into Bar-le-Duc and while there kept an eye peeled for signs of Limey pilots. He saw none—but one of them spotted him. This fellow followed the Yank to a Frog bazaar that sold hardware and, when the Boonetown trickster ankleed out into the darkness, the Limey went in and asked the merchant what Phineas had purchased.

"*Mais oui! Ze paint of gold, oui, mon ami,*" the Frog squeaked. "*Ze Americaine* he say somezing about ze 'Limehouse bums,' *oui*. Zey steal eet no more of ze *descendus*, *non*. *Je ne comprend pas!*" He made a voluble negative gesture with both hands and shoulders.

"But I jolly well think I do, Frenchy. Ha! Ha!" the Britisher chuckled. "*Donnez moi ze same thing, oui? Ze Americaine*, he play the trick, *comprenez?* So the English have no sense of humor, eh? Pip! Pip! How much *argent, mon chappez?*"

Phineas made another purchase, however, that the snooping Limey knew nothing about—a bag of the strongest cayenne pepper that could be procured in France. When he got back to the drome, he scouted around for an inner tube and when he had found one, he hied to his hut and went to work. Yes, skullduggery was a prowl all over the sector.

And over back of Metz, a Hun with a head as bald as an egg sat in his quarters reading a challenge. Von Frankenstein's fierce black mustache seemed to leap from one side of his face to the other. "*Gott!* he ground out. "*Ofer Mont Sec at fife by der glock on next Vendsday, if you haff der nerfe! Donnervetter mit Blitzen*. Pingham! I will do vhat all der odders could nodd do, *ja! Gott sie dank!*"

Now the next day a Camel and a Spad happened to spot a Rumpeler over the Meuse and the two Allied crates went to work on it. They washed it up and it drifted down inside the Yankee lines near Thiaucourt. The Camel pilot went back to the drome and reported, in the presence of the aforesaid distinguished visitor, that he had shot down a German Rumpeler. The distinguished visitor shook his hand, all of

which made the Limey's head swell to mammoth proportions.

But then came the argument. Major Rufus Garrity called up Major Fyer-Sayles and demanded proof that his Spad, Lieutenant Bump Gillis up, had not had something to do with the descendu. He asked the British C. O. to accompany him over to Thiaucourt to get a look at the wrecked Rumpier. Fyer-Sayles complied and when they arrived, Lieutenant Bump Gillis pointed to a bullet that had flattened itself against the Mercedes cylinder head.

"Haw-w-w-w!" Bump guffawed. "Carbuncle Pinkham had us paint the bullets in our gun belts with gold paint. Laugh that off, you Limey—er—old chaps!"

"Deucedly odd, isn't it?" Captain Boyles-Ryce said with a wide grin in the direction of Fyer-Sayles. "No end, old bean. You should take a look at our Vickers ammo. The bullets were gilded last night. Rippin', eh, what?"

"H-huh?"

"Our compliments to Leftenant Pinkham," Fyer-Sayles chuckled. "Smart fellow, eh, what? Tell the chap to sit down on his cell bunk and think up some more jolly ol' tricks. Cheerio!"

The Old Man had a time of it keeping Bump from trying to choke the Limeys. In fact he had to use all his own will power to keep from punching Major Fyer-Sayles' laugh down his throat.

Back in Bar-le-Duc Phineas got the news and he threw a conniption fit. "Why the dirty tea sponges! Those bums had me followed, I bet. They—oh, I'll get hunk! You wait!" he raved. "Nobody can steal a Pinkham's stuff for long. It is poison."

MAJOR RUFUS GARRITY bit pieces of his mustache and was about ready to back Lieutenant Pinkham in anything the Boontown plotter planned to do. Anything short of murder—and even that if he could guarantee a good alibi. But luck had been against the Old Man for weeks. He had to play safe.

Not so Phineas Pinkham. In mid-afternoon of the next day, his Spad shorn of all identity, he flew high over Souilly with Captain Howell and the others who made up "A" Flight. He was still smarting under the backfiring of his trick. Then, unwittingly, he got separated from the other buzzards and three wild-eyed Boche spotted him from their ambush behind a cloud. They came tumbling down on the intrepid Yank, opening up with everything they had—and it was more than a handful of popcorn.

"Ow-w-w-w-w!" Phineas ululated, and he tried to get back downstairs with a whole pelt. But then the first Fokker D-7 came in from right angles, the second shot up under the Pinkham seat, and the third jockeyed into a position where he could get a pot shot at the nape of the Yankee wonder's neck!

Phineas stunted the Spad as if it were only a kite in an attempt to save \$10,000 worth of insurance money for the U. S. Government. *Ping!* A wire snapped.

Even so, the Spad was kind to Phineas and did everything he wanted it to do. It even churned out more revs per minute than the maker had ever intended it should. And if it had gone through the maneuvers that the Pinkham stomach was running through, it would have been well beyond the reach of the Fokker trio.

Br-r-r-r-rt! One Boche got too anxious and cut across in front of Phineas. Garrity's problem shot the Fokker's tail off and there were now but two D-7's left. They were plenty, though.

The Spad was getting well used up when a Bristol Fighter appeared off to the left. Two Camels were nursing it along—two Camels whose identification numbers showed brightly in the sun.

"Good ol' Limeys!" Phineas yelled. "I was only kiddin' you chappies. Haw-w-w-w-w! Well, there goes the Heinies! Come back, you yellow bums! I was only startin' to fight!"

But the Bristol kept on going—and so did the Camels.

Phineas called them terrible names. Then the Huns came back and started in on him again, and the miracle man from Iowa was pretty sure he would never survive to keep a date with von Frankenstein. The Hisso coughed and Phineas felt his heart merge with his tonsils when he looked at the loss of revs on the tachometer. Another cough and the prop in front of him wagged indolently. Fabric curled up from a wing and laid its ribs bare.

Phineas started for the linoleum with Spandaus slugs ripping close to his fanlike ears. The limbs of a tall pine tree now made a swipe at the Spad and held on for a few seconds. Phineas, however, had himself unstrapped from the pit by the time the Spad tumbled across Frog real estate. He fell out and went face first into a patch of blackberry bushes. When he crawled away from the prickly entanglement, a couple of doughs were looking down at him.

"Cripes, are ya alive, Lootenant? Ya look like ya was used for a target in a knife-throwin' contest between two cross-eyed—"

"Haw-w-w-w-w!" Phineas laughed. "You are a scream. Start runnin' before I get on my feet or I will cut your throat!"

"I was bettin' my pal, here, ya would git down from that fight all right, Lootenant. Pay me, Pooley."

As groggy as he was, Phineas got up and chased the doughs across two meadows. Then he sat down and promised plenty of trouble for the Limeys. "I will go right to their faces an' tell 'em what I think! The first truck that comes along—er—what's that I see over there? Why it's a motorcycle! Them doughs—I better get to it before they double back." He jumped up.

Over the hills and through the woods to the Limey drome went Lieutenant Pinkham. He rode right by a shouting Limey sentry and right into the drome where three Camels crouched. He saw no sign of the Bristol—but he recognized the two Camels that had been with it.

Across the field squatted a long shack with an elephant-iron roof. Little slits



P. W. MAKES MODELING EASY

PLASTIC WOOD is the ideal modeling medium. It handles like putty, and hardens into real wood that can be carved, sanded, lacquered, painted or varnished.

You'll find PLASTIC WOOD corrects errors and fills cracks or holes easily. Get it at paint, hardware, and 10¢ stores.



PLASTIC WOOD

JOINS AND REPAIRS

At Paint, Hdwe., and 10¢ Stores.

Excellent for use in model airplane making. Joins and repairs china, glass, wood, celluloid—quickly and permanently. Try it!

TRANSPARENT OR METAL COLOR Old English CEMENTS

Given WATCH, CAMERA or RIFLE
Given for selling 20 packs of Garden Seed. We trust you. SEND NO MONEY. Write today.

EASTERN SEED CO.
Dept. A-32, Lancaster, Pa.

WRIST WATCH
We also have Wrist Watches, Gorgeous Dinner Sets, 35 other Prizes. **WRITE TODAY**

NOW ONLY \$5.00 REAL ENGINE VALUE

Over 7,000 GHQ Gas Engine kits have been sold at \$8.50. Now is your chance to buy the New Improved Kit for \$5.00. Absolutely complete with coil, plug, etc. Send only \$1. Shipped Exp. Coll. for balance same day. Catalog 3c.

All Parts Finished & Guaranteed
Total 1/3 H.P.

A screwdriver is the only tool needed. Average assembly time 30 minutes. For Boats, Planes, etc.

GHQ MOTORS, 854F East 149 St., New York

of light were visible at the windows. To the ample Pinkham auditory assembly came muffled sounds of revelry. Toward this center of social activity he rode. He hopped off the mechanical bug and tramped right into the Limey mess hall.

British flying officers, red tabs, and the like, stopped in the midst of a toast and eyed the bedraggled Yankee pilot. Phineas announced that he wanted to talk to two Camel pilots that had acted as nursemaids to a Bristol a few hours ago. "Oh, I know the bums are here!" he ripped out. "Their Camels are out there. They are cowards in the enemy's face. They flew right by a dogfight I was in and didn't even stop. They left me fightin' three Krauts. Where are them Limey tramps?"

"That's enough!" exploded Major Fyer-Sayles, extricating himself from the group. "You've got colossal cheek, you ugly, jail-breaking beggar! There were no Camels up with any Bristols this awfternoon, you bloomin' blighter! I was at Vaubecourt myself. But I gave orders. A Bristol? Ha! Ha! You're balmy, ol' chap. Now you leave here before I have you—"

"Oh, yeah? I will lick every Limey

pilot here who says I'm a liar," Phineas erupted. "They left me to get washed up! Have I got to send you tickets to my fights? Oh, I will report this. See if I don't."

THE LIMEY PILOTS looked flustered. Major Fyer-Sayles coughed with embarrassment and tried to calm Phineas down. "Leftenant, ol' bean, you are not yourself, man! We have a very distinguished guest here, and—"

"I don't care if it's King George!" the Yank snapped. "You Limeys are goin' to listen to what I think of you bums. I almost 'went west' just because—"

A lithe figure now wormed through the knot of officers and moved toward Phineas. He wore the uniform of the British Flying Corps and his visored hat shaded his eyes. "I'd like to talk to the American chap," he said to the Limey C. O. "Jolly sort of fellow, isn't he?"

"Oh, don't be sarcastic," Phineas countered. "If you were up there gettin' your pants burned with tracers an'—"

Horror and consternation wrestled

for supremacy on the faces of the Limey flyers. The C. O. was fighting off a stroke and looked as though he would lose. "Leftenant Pinkham," he finally gasped, "you are talking to His Royal Highness, the Prince of Wales!"

"Haw-w-w-w!" Phineas snorted. "Don't kid me. You know how I am, ol' chappie?" he said to the distinguished guest. "I am the King of Spades. Haw-w-w-w! What prince would get this close to a *guerre*?"

"Damme!" a red tab said. "This is a positive affront! Major, have that man placed under—"

The guest of the Limey squadron smiled and waved the C. O. back to his place. "Heard a lot about you, old fellow," he said to Phineas. "Been anxious to meet you, Leftenant. But I jolly well will not accept a cigar, eh, what? Ha!"

"Do you know I like you, ol' tomato," Phineas chortled suddenly. "You've got a sense of humor and look more human than these other sour pussers. No kiddin', are you a prince?"

The young officer reached inside his spick and span tunic and withdrew a thin leather case. With a smile and a snappy salute, he handed it to the flyer from the U. S. A.

Phineas' eyes popped out when he examined the credentials. He was looking at the coat-of-arms of the House of Windsor, plus plenty of other proof that here, standing in the flesh, was the heir to the British throne. The shock unsteadied Lieutenant Pinkham for a moment, numbed his senses.

But only for a moment. In the next few seconds, while red tabs and Limey pilots stood as if frozen, the Pinkham brain clicked with the usual rapidity. The two-seater Bristol! Camels nursing it! Hurrying away and leaving an Allied ship to the mercy of the bad Boche! Sure, that was it!

Phineas then quickly resorted to prestidigitation as he fumbled with Wales' leather case. Sleight of hand was one of his many accomplishments. He pushed a hand into his pocket, quickly drew it out again as though embarrassed, and with a grin he closed the leather case and handed it back to the Prince.

"Gosh, I never figured on meetin' you, Your Highness," he beamed. "How's everything in London? Do they still have swell fish and—"

"Har-r-rumph!" rumbled the Limey C. O. "Don't mind the blighter, Your Highness."

Windsor held up his hand. "I'm enjoying this no end, Sir. Fine chap, indeed. Somebody give the fellow a drink."

"Now you're talking my language," Phineas laughed. "Haw-w-w!" A drink was put in his hand.

The Prince lifted his glass. "Happy landings, old chap!"

"You said it," Phineas glowed and drank the brandy at a gulp. "And if you're around Mont Sec tomorrow, you will see me knock off von Frankenstein. Toodle-oo, old chap! Wait 'til the boys back in the barbershop in Boonetown hear about this. You're a sport, Sir! One of the best I ever met. Cheerio an' all that. Pip! Pip!"

What Do YOU Do When You Miss FLYING ACES?

THERE isn't much you can do! You're "grounded" until next month. And if you don't take-off then for your newsdealer, right smack after the publication date, you may be out of luck again.

Insurance companies won't protect you against "sold out" reports on your favorite aviation magazine. But *we* will—with our special \$1.00 "Insurance Policy" which guarantees you a copy of FLYING ACES magazine every month.

SHARE IN THE "DIVIDENDS" TOO

HERE'S how our "policy" works. F.A. costs 15c on the newsstand. Seven copies cost \$1.05. But keep that extra nickel and send us the dollar bill direct. And we'll send you—not the next seven copies—but the next nine! Thus you really get a 35c "dividend" and are sure of your magazine direct by mail for the next nine issues.

HOW'S that for a bargain? And you'd be still more pleased if you could inspect our F.A. "flight plans" for the next several months. They cover the finest flying features *any* magazine could ever offer at *any* price. Fill out the coupon *now*—and see for yourself.

THIS OFFER DOES NOT INCLUDE
F.A.C. RING OR BRACELET

GOOD ONLY IN U. S.
AND POSSESSIONS

Subscription Dept., FLYING ACES, 67 West 44th St., New York, N. Y.

Gentlemen:

You betcher goggles I'm insuring! Shoot those nine issues direct by mail. I enclose \$1.00 to pay for seven of them—the other two are my "dividends." Start with the issue.

Name

Street and No.

City and State

PHINEAS went back to the Ninth Pursuit and directly to his hut. He sat down and pulled a piece of folded paper from his pocket. It bore the crest of the Windsors. He read some writing, then folded the paper up and put it back into an inside pocket.

"Wow!" he said. "I've got the Limeys where I want 'em now! Strike me pink, an' all that slush! Haw-w-w!"

An orderly interrupted with a message that Phineas was wanted in the Operations Office.

When Lieutenant Pinkham limped into the O. O., Garrity roared at him: "Where've you been?"

"Out with the Prince," Phineas retorted. "Boys, he is a swell guy!"

The C. O. looked askance at his thorn-in-the-side and swore. "Get out of here," he bellowed. Then he calmed down suddenly. "Ha! Ha! I was only kidding. How about a drink, Pinkham? Could use it, eh? Here—help yourself. Come back later and we'll talk."

The next day would be Wednesday, Phineas mused as he went out grinning, when he had a date over Mont Sec. He had a job to finish before that time, though. The biggest slingshot that was ever invented. He would have to get Casey in the right mood to help him, so he went over to his hut and got a deck of marked cards out of his trunk. Casey would go for them.

And Casey did. "Gee, t'anks, Loo-tenant," the flight sergeant enthused when Phineas gave them to him in the hangar housing "A" Flight's Spads. "I need some francs. Now who ya want killed?"

"Haw-w-w-w!" Phineas guffawed. "Only the C. O. But why end his worries? I have a tricky job to figure out and put on my crate by tomorrow late in the P. M. Now shake a hand that's held the hand of the next King of England, Sarge."

"Huh? Say, Loo-tenant, that last crackup maybe—?"

"Awright. Forget it and let's get to work. Now we take this inner tubing and fix the ends to this chunk of wood. We've got to figure out a way to hold . . ."

Anyhow, Phineas didn't get back to his hut until about two in the morning. As soon as he hit his bunk he started dreaming that he was in Buckingham Palace with short pants on and silk hose, teaching Royalty how to make an omelet in a high silk hat without spoiling the hat.

EARLY THE NEXT MORNING there was a pow-wow in Captain Boyles-Ryce's quarters over at the Limey drome. "The balmy Yankee Leftenant has got a scrap on today with the Boche Baron. I'm jolly well certain of it, old chaps, for I've had a man busy checking up on him. Now the Prince would be no end disappointed if an American should down the great von Frankenstein. Frightful black eye to us an' all that, y'know. Follow me?"

"Quite, old chap," replied the pilots in chorus.

Boyles-Ryce poured three jiggers of brandy. The Limeys drank to the King and to the Camel skipper who was going to make a try at snatching Frank-

enstein out of the Pinkham clutches. Captain Boyles-Ryce was certain that the downing of the Munish Monster was entirely up to him. He spoke disapprovingly of the Pinkham prowess, drank to the King again. He hoped to bring von Frankenstein in on the hoof and give him to Windsor as a memento of his visit to the British Camel squadron.

The day wore on. At 4:45 P. M., the Pinkham Spad was trundled out onto the field and Major Garrity and a dozen pilots swarmed around it. The contraption that had been built onto the fuselage behind the pilot's pit was really something to look at. It was a cross between an ancient cross bow and a modern slingshot. The missile that was set in place provoked much guesswork on the part of the buzzards who were not in on the know. Phineas came across the field as nonchalantly as though he were on the way to a strawberry festival.

"You'd better not come back if that Kraut licks you," the Old Man warned him. "That Limey brass had called me up twenty minutes ago. He's going to call up Chaumont and find out why you can't be kept under arrest. I called him a poisoned airedale, Pinkham, and he's

Now is the time to . . . Get Into AVIATION Train at LINCOLN

AVIATION CALLS YOU TO GOOD PAY JOBS!

Bill Burgess, the Pilot pictured below, trained at LINCOLN. Now he pilots his plane all over the country in aerial mapping service. Travel, adventure, good-pay are Bill's reward for training at Lincoln, a Government Approved School.

BE A PILOT, MECHANIC or an AERONAUTICAL ENGINEER

Lincoln Training has helped hundreds to success in Aviation. It can help YOU prepare for a good position as Licensed Pilot, Mechanic or as Aeronautical Engineer. Here you can learn to fly fast, modern airplanes; overhaul and repair modern aircraft motors; assist our Engineers in building real airplanes.

GOOD POSITIONS and GOOD PAY in Aviation. Many make \$200 to \$600 a month. We train you and assist our Graduates in locating positions.

MAIL COUPON TODAY for complete information.

LINCOLN AIRPLANE & FLYING SCHOOL
264 Aircraft Bldg., Lincoln, Nebraska

I'd certainly like to get into Aviation. Please send complete information about Lincoln Training.

Name

Address

City State



Send Sixteen Different Signals By Radiol



Learn How To Build Model Radio Controlled Boats & Planes

Operate Planes, Boats, Etc., by Wireless

Build Model Radio Controlled Boats and Airplanes! We have developed a simplified plan for constructing the mechanism that will operate boats and planes by remote control. It's fun to build—and it's fun to operate. When completely built, you can control boat or plane by means of a telegraph key. There are 16 different signals that can be transmitted so you can control as many different contrivances—lights, rudder, motor, etc. These plans are the result of research by U. S. Government, engineers, etc. Simplified, comprehensive plans for the radio control unit and model are given. There are no wires or connections. It is by wireless radio. Description and interpretation of plans accompanies drawings. Get in and enjoy this new field in model building. First, it was model planes, then came Gas Engines, and NOW RADIO CONTROLLED PLANES! COMPLETE SET OF PLANS, POSTPAID ONLY. **25c**

Practical Remote Control



PRINTING PRESS



Does Real Job Work!

\$2.98 PAID

DO YOUR OWN PRINTING

A REAL PRINTING PRESS! Prints STATIONERY, TICKETS, CARDS, NOTICES, CIRCLERS, BILLS, ETC., ETC. In 16 metal type—any color. Prints several hundred copies per hour. Also makes many business forms, etc. Press rigidly constructed of metal. 11 1/2 inches high. Has removable chase, self-inking roller. Paper feed guides. Prints 2 1/4 x 3 1/2". PRICE of complete outfit including type, paper, ink, brush and directions. Shipped Postpaid Only **\$2.98**

Ready-To-Fly Airplanes Nothing To Build

It's fun building airplanes, but it's more fun flying them. These airplanes are all built, you just have to wind them up and let them fly. They are made of Balsa, LONG ENDURANCE PLIERS that look good up in the air. Nothing to build.

Contest Model Climber Lightly built rubber band motor. A good contest model. 18" wingspan. Price Postpaid **15c**

Hi Flyer Deluxe Beautifully finished, lightweight plane that flies on many forms in endurance and high flying. Price Postpaid **29c**

IT GOES! Under Its Own Power!

A well-balanced craft, light and graceful—a boat that fairly skims over the water at a high rate of speed—just like a real boat—by its own power. Flies on in a lake, bath or wash tub. Made of ocean resistant and highly finished material. Has its own motor, fuel tank, in motion makes a noise not unlike the exhaust of an airplane motor. **PRICE POSTPAID ONLY. 25c**

CRYSTAL RADIO 25c

This is a special gift! It is possible to receive radio signals within 25 miles of a station or up to 100 miles under good conditions. All you need is an aerial and ear phone. Completely assembled & wired with super-sensitive crystal stand, battery, crystal cup, arm with coil, etc. Reception guaranteed. **25c**

ELECTRIC BASEBALL GAME

The New Baseball Game Sensation!

The player can "pitch" a "Slow Ball," "Fast Ball," "Outsider" or "Batter" with a "Pitcher" that works on new principle. Dozens of different plays. Strikes, swings, and Texas Leaguers, Doubles, Home Runs, Errors, Base-runner hit by Batted Ball, Out at Home, etc. Scientifically constructed. Thrills, excitement, that Out of This World! Fun! Includes Batter, Home Run Shifter, etc. **PRICE POSTPAID. \$1.00**

MIDGET RACER

Complete diagrams for 3 different racers. The one illustrated can be built very cheaply. All about racer parts, gears, transmissions, dirt track racing, track racing, etc. How to build a racer. Includes diagrams, Midget Motor, etc. Examined & stamped full of instructions. Over 25 illustrations. **PRICE POSTPAID, 25c.**

MYSTOPLANE

A wave of the future controls the plane. No connections, no springs. What makes the plane fly? It's mystifying—but there is the airplane soaring through the air, while you control it with the Magic Wand. Drive a plane, etc. Outfit includes wand, planes. **Price Postpaid. \$1.10**

ALL-METAL MODEL AIRPLANE!

The most sensational model airplane made entirely of light-weight metal. Aluminum and brass. Includes complete instructions. Will fly right from the start and stand up to the very last. Complete shown as the last detail in spreading streamlined about engine block, adjustable tail assembly, etc., etc. Wingspan 25". **25c**

Build Rocket Planes

The "Rocket" is built with a fast powerful Rocket Ship. It's a real flying model of your own. Be the first in your neighborhood to build one. Book tells how to build rockets used in model airplanes, etc. Rockets easily built from inexpensive materials readily obtainable. **PRICE POSTPAID. 15c**

One Passenger Airplane plane. Includes complete plans. Built from old tin. **25c**

OUR BIGGEST CATALOG 576 PAGE CATALOG FOR 3c!

★ 6000 AMAZING, SENSATIONAL NOVELTIES ★

Rush 3c for this jumbo catalog of unusual novelties. Radio, optical goods, novelty jewelry, unusual books & cards, puzzles, hobby kits, free animals, punchboards, films, games, fireworks, etc. Surprises, job goods, magic, outdoor & sport items, household labor-saving devices, musical instruments, puzzles, watches, etc. **3c**

Johnson Smith & Co., Dep. 724, Detroit, Mich.

Reg. Catalog, 3c. Cloth Bound Edition, 25c.

Name

Address

— THEY ADVERTISE — LET'S PATRONIZE —

after my skin, too. Why didn't you join the Navy?"

"Keep your chin up and your blood pressure down, Major," Phineas chirped, climbing into his Spad. "Frankenstein has chalked up his last kayo and he will be a stumblebum by suppertime. Adoo, bums! Contact! Pip! Pip! An' all that rubbish, eh, what? Haw-w-w!"

Meanwhile, there was a Camel purring on the Limey drome with Captain Boyles-Ryce, Limey ace, standing nearby, his monocled eye glued to a wrist watch.

At this time, too, Baron von Frankenstein winged out of Alsace, his eyes as cold as an Eskimo's back porch, his dental assembly bared. "*Ach, der Tag!*" he gloated. "*Nefer I lost yedt, nein! Das Pingham he ist already yedt by Mein victory list Noomber Eightdy, ja. Verdammst oopstardt! Cumst der Morgen und I gedt idt der Iron Cross from Potsdam—and Pingham he gedts idt der vooden cross by der grafeyard, vunce!*"

Hissos, Mercedes, and Bentley Rotaries were built during the gigantic embroglio to get people places in a hurry. Von Frankenstein got over Mont Sec in his favorite Albatros forty-one seconds ahead of Phineas. And when he spotted Garrity's duelist, he had four thousand more feet of altitude than the Yank. "*Dumkopf!*" he gutturalized gleefully, shoving the stick away from him. "*Ach, das ist too easy yedt, ja!*"

THE Boonetown ace had hardly started fencing with von Frankenstein when he sighted the Camel coming up, and he gnashed his buck teeth until the enamel threatened to chip off.

"Hornin' in on my party! Trying to steal the Von, huh? The Limey bum! That's what he thinks!"

The Munich Monster was not in a good humor himself. "*Ach, two off der flyers they need, hein? Der trick ist. Das Pingham ist ein sport, hein? I show der bummer. I gedt Pingham first, den afterwards I shoodyt down das Camel, too. Hoch der Kaiser!*"

The Albatros blazed right after the Spad and got within fifty yards of the Pinkham tailboard just as Captain Boyles-Ryce winged over and came shooting down.

Abruptly, Phineas whipped out a knife and cut a cord that was strung along his pit.

KER-WHA-A-A-A-ANG! TW-W-W-ANG!

Baron von Frankenstein saw an object hurtling at him—saw it too late. It smacked into his prop before he could lift the nose of the Alb out of range and the whirling piece of engine lumber banged what turned out to be a bag of pepper to bits and sucked in great whiffs of the cayenne condiment that packed a mule's kick. The Von's nostrils were

filled with it! So was his throat! He felt as if he were on fire from the neck up. Tears streamed down from his peepers and fouled his goggles. He coughed, then went into sneezing spasms. And the Alb followed suit. The Munich Monster was now rendered as harmless as a kitten, and his crate spun down through the ether.

Then the Limey ace hopped on him before Phineas could go up and spiral down. Vickers pounded.

"Oh, you dirty tea sipper!" Phineas howled, now feeding von Frankenstein a lot of mayhem himself.

The Munich Monster cracked up fifty yards from a Yankee communication trench and Captain Boyles-Ryce and Lieutenant Pinkham swooped low to see some doughs rush out to inspect the remains. Both pilots then went home. And fifteen minutes after Phineas landed on the tarmac of the Ninth, the news came through that Captain Boyles-Ryce had downed von Frankenstein.

"Oh ye-e-ah?" the Yank grinned. "Why I peppered the pants off of that bogey man. Get the squadron car, as we are goin' over an' pay a call on them pip-pip palookas. An' tomorrow we will really see who shot down von Frankenstein. Yes, sir!"

MAJOR GARRITY, Phineas, and Flight Captain Howell sped toward the British drome. They arrived there with their dander up and walked directly into the Limey Operations Office.

"So Boyles-Ryce shot the Baron down, huh?" Phineas began, pointing a finger right at Major Fyer-Sayles. Why, Boyles-Ryce knows he is a liar. I got that Kraut ready for the cleaners, and—"

"Garrity," exploded the Major, "this is the last straw, by jove!"

"Blarst it, Pinkham," the Limey ace said, coming in from the mess bar, "you jolly well don't question my victory over the Biffing Baron, do you? I'll have you know confirmation came from—"

"Now just sit down, all of you," Phineas broke in, drawing folded paper from his pocket. "Here's a note—a sorta diary note—written on Buckingham Palace stationery with a coat-of-arms on it and everything. I mean it don't belong to no panhandler. Listen—"

"Today, twenty-eighth April, Nineteen-Eighteen, I experienced the greatest thrill of my life, no end. After much difficulty I persuaded the pilot of a Bristol fighter—who landed on the Camel drome for fuel—to take me for a trip over the lines. Two Camels accompanied us as escort and on the way home I witnessed an aerial fight between three Boche and a brave American flyer. The pilot of the Spad fought gloriously, but in vain. I suggested that we take

a hand in the fuss, but my pilot insisted that he must not risk my life. So he continued on home"

Major Fyer-Sayles looked as if he had swallowed a spider. Captain Boyles-Ryce tottered a little and looked around to see where he had left his drink.

"Cripes!" breathed Major Garrity.

"Awright," Phineas grinned. "Now, should I tell that to the King? What will the Queen Mother say when she finds out you took the heir to the throne over the lines, huh? I bet even the Air Minister will get fired. Boys, what a shake-up in the R.F.C., eh, what, ol' turnips? Pip! Pip! Cheerio, an' all that rot. What I mean is—er—well, Who shot von Frankenstein down, huh?"

Major Fyer-Sayles looked daggers, stilettos, and broadswords. "Uh—er—Leftenant Pinkham, I—er—will 'phone Brigade to that effect. Tell the blighters there was a—er—slight mistake—er—uh—now if you'll give me that note—"

"Oh yeah?" Phineas chortled. "I will see you after the *guerre* about that. Haw-w-w-w! Anyhow, we must have co-operation if we are to defeat the Boche in this sector. Comprenny? Anyhow, when I get the two hundred pounds cash, I will throw a binge, as our outfits should get better acquainted, eh, what, ol' potatoes? Now just call up Brigade while we are here."

Major Fyer-Sayles obeyed with alacrity. When the error regarding the descendu was rectified, Phineas bowed low. "Bong swar, ol' beans. A cheerio and a couple of jolly whats, strike me bloomin' pink, white, an' blue! C'mon, Major!"

"Pinkham," the Old man enthused as the squadron car rolled toward Bar-le-Duc, "you're a positive genius."

"It took you a long time to find out. Haw-w-w-w!"

BUT, dear reader, there is an anticlimax to this tale. At that very moment a big car was trundling across France toward Laon. In the back seat a young man drew a leather case from his pocket looking for a diary note that he wanted to finish. He plucked a folded piece of white paper loose and spread it open. Then the heir to the British throne gulped in great surprise. He read:

Nifty Novelty Co., Inc.
Milwaukee, Wis.

To Phineas Pinkham, Debtor:

3 Rubber pistols, No. 45 J \$2.25

Please remit. This account is long overdue and we are losing patience with you. If we do not hear from you within three weeks, we will put this matter in the hands of our lawyers for immediate action.

J. Muzzygummet
Credit Department.

On the Light Plane Tarmac

(Continued from page 23)

think my swell idea is so hot. "The plane is much too busy," they tell me. Or they "don't like the looks of that haze" over their pet weather hill.

Another stock refusal goes: "Sure,

you can have our ship. But it will cost you flying time all the while it is away from the field." Well, who wants to go visiting a friend at a field an hour's flying time away if it's going to cost

\$8.00 an hour to talk to him after you get there?

That's just on wheels. Well, I like floats. So do lots of other people I know. But the law says we can only land on

tide water! So we in New Jersey have three strikes on us before we start. We have beautiful lakes and lots of friends on them—but we can't go to see them.

Yet even if there wasn't such a law, the operator would probably crack: "But is there a dock?" . . . "Can you beach a plane?" . . . or "I've never been there myself, so I don't think you'd better go."

That's the sort of thing that makes us renters give up and disgustedly drive back home through the Sunday traffic.

And did you ever want to rent a plane and stay overnight somewhere with it? Camping out, I mean. I suggested that to one operator—and was he shocked! "Where would you land—just in a field?" he began. Then: "Sorry, but I couldn't let you do that at all."

So there went another of my favorite dreams—postponed until I get my own skyster. And maybe I should be patient until I do obtain it. But get this: I'm willing to pay good money to rent one now, so why can't I do these things? I could, and would, stand the occasional charges of chartering a plane for my week-end pleasure. I have spent about \$400 already to get my private ticket, and I wish I could make more use of it without letting myself in for the costs of my own ship and its upkeep at this time.

Other flyers I've talked to see along with me on these difficulties, so I'm not talking alone or through my hat.

Some one may get the idea at this point that perhaps I've been refused because I'm a novice with no cross-country experience or avigating ability. But such is not the case. I have about 100 hours, lots of cross-country behind me, and a good knowledge of avigation to boot.

Don't get the idea that I'm writing this just to grumble. Far from it! I'm really quite a happy sort—and I'll fly regardless. But I do have hopes that

some field operator will read this letter and offer a solution to some of these problems.

W. J. SUTTON.
Elizabeth, N. J.

Yes, that's Mr. Sutton's story. And we hope some operator will take a gander at this letter of his and shoot us a reply. We'll be glad to run it here in the Tarmac. Now then—are there any takers?

Happy Landings

(Continued from page 25)

ment for these flying volunteers, depending upon the true military aspects. No one, either civilian or professional soldier, should be expected to assume air duty without life insurance behind him. This was the first obstacle the members of the British Civil Air Guard faced, and later insurance had to be underwritten by several large companies. Eventually, the candidate carried it himself at a small premium fee, and his policy covered him while he was actually carrying out C.A.G. duty.

Second, the candidate should be assured that he is signing up for aviation only. His acceptance must protect him from any emergency draft plan which might compel him to serve in some other branch against his will. After all, he is a volunteer and is entitled to such considerations.

Third, all training should be under the supervision of the Government and carried out at recognized training centers by professional flight-training instructors who are fully qualified for this work. This will protect the present

schools and civilian instructors and promote co-operation between the civilian schools and the services.

Fourth, selection should not hinge on university training or the lack of it. Such education is necessary for Cadets who are to become Regular Army officers. But we think any civil air training plan should be successful, include candidates ranging down to two years of high school training. A small commission could be formed to investigate the backgrounds of the most successful Air Corps cadets and to study the particular qualifications which have made them good pilots. We should find out whether it is primarily education, native intelligence, athletic ability, family background, or simply some inherent quality that makes a man into a fine pilot.

Finally, we should play square in making the selections. No candidate should be accepted simply on his family name, his personal acquaintances, or his political affiliations. Every man who can spare the time—and the program should

IMPERIAL

Visit or mail your orders direct to our new showrooms
263 Main St., Hackensack, N. Y.
Open Saturdays to 9 p. m.

Special! 1 pair 3 1/2" Pneumatic Wheels (value \$1.50) with each order of \$1.50 or over. Add 60c handling charge to order.

- 18" BALSAL 1/16x1/16 100, 5c
1/16x1/16 85 for 5c
1/16x3/16 18, 5c
1/16x1/16 15 for 5c
9/32x3/32 30, 5c
3/16x3/16 30 for 5c
3/16x3/16 12 for 5c
3/16x3/16 10 for 5c
3/16x3/16 8, 5c
3/16x3/16 6 for 5c
1/8x2 4 for 10c
1/32x2 8 for 10c
1/16x2 8 for 10c
3/32x2 7 for 10c
1/4x2 6 for 10c
1/2x2 3 for 10c
5" sheets or 88" lengths, double above prices; add 10c for pkg. charge for 30" lengths.
- 18" PLANKS 1x1 5c; 1 1/2x 6c
1 1/2x 9c; 1 1/2x 10c
1 1/2x 15c; 2x2 18c
2x3 25c; 2x4 30c
2x3 40c; 3x6 75c
- BAMBOO 1/16 sq. 12, 30, 5c
1/16x1/16 15, 5c
- GLASS DOPE OR THINNER 5c per oz.; Large bottle, 8c; 1/2 pt. 30c; 1 pt. 40c
- COLOR DOPE 6c per oz.; Large bottle 10c;
- CLEAR CEMENT 5c per oz.; large bottle, 8c; 1/2 pt. 35c; 1 pt. 50c
- PROPELLERS Balsa Paul-O Mach. Cut Wina 5" 4c 10c
6" 5c 15c
7" 6c 20c
8" 7c 25c
9" 8c 30c
10" 9c 35c
12" 10c 45c
14" 14c
15" 15c 60c
- RUBBER 1/4" dia. 5 ft. 25c
1/2" dia. 5 ft. 35c
3/8" dia. 5 ft. 30c
1/8" dia. 5 ft. 15c
- RUBBER LUBRICANT Lge. bottle .10c
- BAMBOO PAPER White, 2 for 15c. Red or Yellow, 10c ea.
- NOSE BLOCKS 1x2x1 .10c
2x2x1 .15c
2x2 1/2x1 .20c
3x3x1 .30c
3x3x2 .40c
3x3x3 .50c
- CAMEL'S HAIR BRUSHES Small 3c; Lge. 5c; Extra large 8c
- THRUST BEARINGS, dz Sm. 10c; lge. 15c
- PROP BLOCKS 1/2x1 x 8 6-5c
1/2x1 x 10 3c ea.
1 1/2x12 4c ea.
1 1/2x15 7c ea.
- SANDPAPER Doz. sheets. .50c
6-8-10-12-14
2 ft. 1c
1/16 dia. 5 ft. 12
8/32 dia. 5 ft. 15
7/8 dia. 5 ft. 25c
- PROP. SHAFTS, REAR HOOKS Doz. 8c
- TISSUE, AA All col., doz. 10c
Silver 5c
Superfine, wh. 5c
- ALUM. TUBING 1/16, 3/32, 1/4, 7c
3/16, 1/4, 10c
- BUSHINGS 1/16 4 for 1c
- MODEL PINS 1/2" or 1" pkg. 5c
- WASHERS 1 doz. 1/4 or 1/2 1c
- CELLULOID 6x8 5c
12 1/2x16 18c
- REED 1/32-1/16 2 for 1c
3/32x 1 ft. 1c

Used Motors bought, sold, exchanged, or overhauled. Send in your motor for estimate. Motor will be returned at our expense if allowance is unsatisfactory.

- 5-FOOT BALSAL 1/8x3/16, 12 for 20c
3/8x1/4 10 for 20c
3/16x3/16 8 for 20c
3/8x1/4 6 for 20c
1/4x1/2 3 for 20c
3/8x1/4 1 for 8c
3/8x1/4 2 for 20c
Add 25c pkg. charge. Specify hard or soft.
- STREAMLINED ALUM. TUBING 1/4x1/4 ft. 15c
5/16x3/32 ft. 16c
3/8x1/8 ft. 18c
- MOTOR FUEL Pint 30c
- FLIGHT TIMER 50 Sec. 50c
0 Sec. to 1M. 2.00
- INSIGNIA 24 and stripes 5c
- WOOD VENEER PAPER 20x30 . . . 1 for 10c
- MODEL STANDS Sm. 15c; lg. 25c
- PLASTIC BALSAL Large can. . . . 25c
- METAL PROPELLERS 2 blades 3 blades
1 1/2" .5c 08
2 1/2" .10c 15
3 1/2" .15c 20
4 1/2" .20c 25
- NOSE PLUGS 1/2" 12 for 8c
- DUMMY RAD. ENGINE (Cellu.) with or without cowling
1 1/2" d. 15c; 2" d. 20c; 3" d. 25c
- CELLULOID PANTS, per pair 1/4 to 1" 18c
1 1/2 to 1 3/4" 38c
- ALUM COWLINGS 1 1/2" 15c 2" 18c 3" 25c
Specify whether anti-drag or closed
- BOMBS 3/4" .4c 1 1/4" .7c 3" .12c
- GUNS WITH RING MOUNT 1 1/2" 10c 1 3/4" 15c
- WING AND TAIL LIGHTS 12" 10c; 15" 15c 24" 20c
- PURSUIT MACH. GUNS 3/4" 1 1/4" or 1 3/4" each 5c

FREE! One of these FREE OFFERS with all orders for \$1.00 or over. 1. Large bottle clear cement. 2. 2 pr. 1 1/2" Birch Wheels. 3. 3 sheets silver tissue

FREE POSTAGE On all orders in U.S. Add 10c packing charge on all orders (large or small) in U.S.; Canada, U.S. possessions, and foreign, over \$1.00 add 150c. For airmail, add \$1.00. Add 15c. No C.O.D. No stamps.

Dealers: Send for Wholesale Price List 16-page Catalog and List of gas-powered and rubber-powered models and supplies—5c stamp.
IMPERIAL MODEL AERO SUPPLY
416-B McDONALD AVE., BROOKLYN, N.Y.
263-B MAIN STREET, HACKENSACK, N.J.

Rebuilt by WOODSTOCK BUILDER

Winner... Most World's School Contests—**EASY TERMS—FREE TRIAL**
WRITE FOR LITERATURE DEPT. B-26
WOODSTOCK TYPEWRITER CO., WOODSTOCK, ILL.

ATTENTION

We will give FREE with each 36" FLYER a beautiful 9" aluminum prop.
1—Army Boeing P26A 4—Curtiss Robin
2—Seversky B7B 5—Champ Endurance 65c
3—Curtiss Army Hawk PGE 6—Cessna.

SEND FOR FREE GAS AND RUBBER CATALOGUE DEALERS, CLUBS, SCHOOLS WRITE FOR SPECIAL DISCOUNTS
H & F MODEL AIRPLANE CO.
459 BRISTOL STREET, BROOKLYN, N. Y.

BENJAMIN AIR PISTOL WITH LEVER HAND PUMP

For Target—Small Game—Camping—Etc.
Guaranteed—Accurate—Practical—Economical—Safe—Clean—Quiet—Adjustable Force—Amazing Maximum Velocity. No Smoke or Puff. Bolt Action—Hammer Fire—Hair Triggers—Safety Lock—Hand Pump. Single Shot BB \$8.50; Single Shot cal. 177 or 22 with rifled barrel \$8.50; BB \$8 Shot \$10.00; Holster \$2.50. Also a complete line of Benjamin Gasoline Compressed Air Rifles for BB and cal. 177 or 22. No license required from dealer or factory. Ask for complete specifications and free targets.
BENJAMIN AIR RIFLE CO., 850 MARION ST., ST. LOUIS, MO., U. S. A.

GIVE ME 7 DAYS TO PROVE I CAN MAKE YOU A NEW MAN—

I changed myself from a 97-lb. weakling to winner of title, "World's Most Perfectly Developed Man." Let me prove—in 7 days—that my secret of Dynamic Tension will make a NEW MAN of YOU—give you glowing health, smashing strength—banish constipation, bad breath, indigestion. Thousands praise my natural method. Write for FREE BOOK of actual photos. **CHARLES ATLAS, Dept. 49-D, 115 E. 23rd St., N. Y. City.**

SEND FOR MY FREE BOOK

BUYERS' DIRECTORY

Airplanes and Accessories, Schools—
Flying Instruction
\$5 per inch—Payable in Advance

APPRENTICE TRAINING

AVIATION APPRENTICES

Airminded young men interested in training for entering the well-paid field of Aviation as apprentices—Write immediately, enclosing stamp.
Mechanix Universal Aviation Service Co.
Wayne County Airport, Box 867, Dept. K
Detroit, Michigan

AIRPLANE SUPPLIES

LEARN TO FLY

In your plane. The Flying Ground Trainer. Eligible in every state in the Union. Shipped with a sealed throttle, oversize air wheels. Sled runners for winter use. Detach wings and use as high speed ice sled. Welded steel tube construction. Equipped with 40 h.p. aircraft motor. Easy payments, only \$12.50 down. Rush 25c for illustrated information.

UNIVERSAL AIRCRAFT CO., Ft. Worth, Texas

PATENT ATTORNEY

PATENT YOUR IDEAS
Send a Sketch or Model of your invention for **CONFIDENTIAL ADVICE** FREE CONSULTATION LITERATURE
J.H. Polachek
REG. PATENT ATTORNEY
1237 BROADWAY
NEW YORK
LONGACRE 5-3088

NAME _____
ADDRESS _____

CLASSIFIED DIRECTORY

Use this Directory for prompt response. Rate: 10c per word (minimum 20 words). CASH WITH ORDER.
Make remittances payable to:

FLYING ACES
67 West 44th St., New York

MODELS—MATERIALS—EQUIPMENT

DEALERS—SCHOOLS—CLUBS
NEW 1939 CATALOG, complete selection of supplies, kits, motors, specialties. New low prices. Special FREE deals. Write on letterhead. Mercury, 1592 (F4), Lincoln Place, Brooklyn, N. Y.

PLANES FOR SALE

C2-AERONCA \$125; LINCOLN-SPORT, \$95 less motor; WACO-10 uncovered \$85; Curtiss Robin, \$125; OX-planes \$100 up flyaway. 130 others, located everywhere. Terms, trades. Spring catalogue 25c complete. Used Aircraft Directory, Box 0-456, Athens, Ohio.

INSTRUCTIONS

AVIATION APPRENTICES—Airminded Young Men interested in training for entering Aviation as Apprentices see Mechanix Universal Aviation Service ad above.

1939 U. S. GOVERNMENT JOBS, \$105-\$175 month. Men-Women. Prepare immediately at home, for (next) examinations. List positions free. Write today. Franklin Institute, Dept. H43, Rochester, N. Y.

STAMPS

1939 STAMP ANNUAL FREE—Features Canadians, Newfoundland, United States, Colonials, Foreign, Sup-plies, Sixty pages with Hundreds of Illustrations. Sent FREE. GRAY STAMP COMPANY, Dept. FA, Toronto, Canada.

INVENTORS

TIME COUNTS—don't risk delay in patenting your invention. Write for new FREE book, "Patent Guide for the Inventor," and "Record of Invention" form. No charge for preliminary information.

CLARENCE A. O'BRIEN
& HYMAN BERMAN
Registered Patent Attorneys

5847 Adams Building, Washington, D. C.

COMET CLIPPER, JR.



LOOKS, SOUNDS, FLIES LIKE A GAS MODEL

Motor roar device, imitation gas motor, big 64" wingspan; metal cylinder flanges, detachable wing, finished propeller, plenty of rubber. Complete kit, \$1.00; postage 15c, or buy from dealer. Send 5c for catalog to COMET, 2509 Cermak Rd., Chicago, Dept. F-4.

\$1.00

JUST OUT—36 PAGE CATALOG

Hundreds of models, 10c up, including famous Comet Clipper Gas Model, \$4.95; also motors and accessories. Send 5c stamps to COMET, 2509 Cermak Rd., Chicago, Dept. F-4.

be designed with a very wide scope so that the fellow who works ten hours a day can still be included—should be given an opportunity to take part in this all-important volunteer plan.

Twenty thousand pilots are a lot of pilots. But the plan can be put over if a sane system is first devised. The farm boy should be given the same chance as the city boy. And how much money a

fellow's father makes should have nothing whatsoever to do with it.

And so, reader, if you're really interested in the training plan sit down and weigh and sift the facts carefully. Don't take it for granted, either, that the Powers-That-Be already see it your way. Write to your congressman and respectfully tell him of just how the plan stacks up to you.

Gas Job Knee Action

(Continued from page 46)

iron and flow enough solder on to insure a good bond. Then attach the complete outfit to your model, using the small ball and socket joints depicted in the drawings.

After placing several rubber bands on the sliding members, fasten the lower ends of the struts together with size 2-56 bolts. Fit wheels with cotter-pins, or with drops of solder, on the ends of the axles.

Adjustment of the gear will be determined by the weight of your particular ship. The number of rubber bands you

should use can readily be determined by experimentation. But do not be afraid of trying a great number the first time, because the gear flexes surprisingly, even with a lightly loaded plane.

Reduce the tension gradually until the landings are smoothed out to your liking. Then try her a few more times to be sure that your calculations were not all cockeyed. And if, after several more landings, the ship still settles the way you want her, then head for the nearest and roughest field and—give her the gun!

The Curtiss XP-40

(Continued from page 35)

Lower one end of the rubber motor into the fuselage and fasten it to the rear hook. The other end is attached to the hook on the prop-shaft. Be sure the opening in the front of the fuselage nose is large enough to allow the rubber strands clear operation.

ASSEMBLY AND FLYING

IN ASSEMBLING the wings and tail members to the fuselage apply plenty of cement at all joinings. It is advisable to use small wood props under the extreme ends of the wing tips and horizontal tail members. These will hold the parts in position while drying as well as to serve in properly aligning the members in relation to the others.

The ship is painted aluminum throughout. To get an exceptionally fine finish, apply three coats of wood filler to all wood parts. After the last coat, sand over the wood surfaces with wet emery paper and then dry thoroughly with a rag. Now apply a single coat of bright aluminum paint to every part of the ship.

Parts such as the radiator, wheels, and hinge-lines are touched up with black paint. The rudder markings in red, white, and blue are painted in position. And regulation stars on both upper and lower surfaces of the wings are also attached. The words "U. S. ARMY" are divided by placing "U. S." on the under surface of the left wing and "ARMY" on the under surface of the right wing. The letters should be black.

Before test hopping, glide the model over clear ground. You'll be able to determine in this manner just which way the model should be balanced for power flights. Give the prop about fifty turns for hedge-hopping flights at first. Tricky characteristics, if any, will manifest themselves during these first flights.

Now, if everything is all set, take

your XP-40 out to the nearest field, wind 'er up to capacity, and let 'er go—but have plenty of room around you!

Answers

TO QUESTIONS ON PAGE 24

- 1—Firms are now experimenting with the building of airplane bodies out of plastics (formed in moulds under great pressure). If successful production will be speeded up in this manner.
- 2—A sirocco is a hot, oppressive dust-laden wind experienced in Northern Africa. Nope, flyers don't like 'em.
- 3—The Fairey "Flycatcher" was a single-seat fighter biplane formerly used by the British Fleet Air Arm. It was powered with a 385 m.p.h. Jaguar engine.
- 4—To our knowledge, no German multi-seat plane has yet appeared with any form of automatic turret aboard.
- 5—The Bergamashi A.P.1. is a single-seat attack-fighter plane designed for the Italian Air Service.
- 6—Some Still Live was written by F. G. Tinker, an American flyer. In it he describes his experiences while flying for the Loyalists in Spain.
- 7—The new Halford-Napier "Dagger" engine, of 24-cylinder design, is now rated at 1,000-h.p.
- 8—There is no record anywhere showing that poison gas has been successfully discharged on troops or cities by bombs dropped from airplanes.
- 9—Aircraft motors can be stopped if ice is allowed to form on the carburetor. When humidity is high, the evaporation of gasoline drops the temperature of the mixture below the freezing point and the moisture contained in the air condenses on the manifold walls and freezes. This ice gradually builds up and chokes off the manifold passage, eventually stopping the motor.
- 10—The word "aerostation" refers to the art of flying or handling lighter-than-air craft, as opposed to heavier-than-air jobs.

POLK'S — Pioneers in Power Plane Promotion — PRESENT

SMALL BORE ENGINES

We've Got 'Em All!

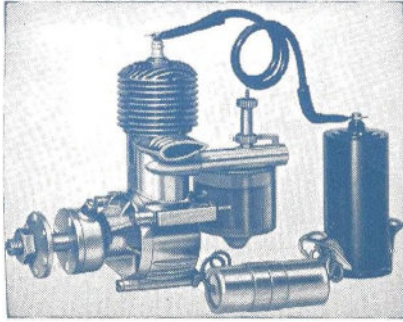

OHLSSON "23" \$16.50
 HI-SPEED \$12.75

AND ALL THE OTHERS
 LARGE OR SMALL

POLK'S O. K. THE O. K.

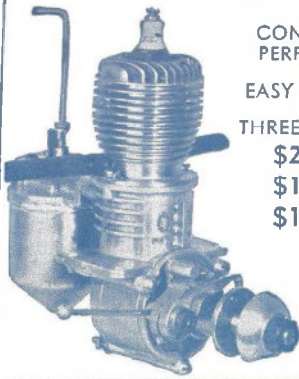

CONSISTENT PERFORMER
 EASY STARTER
 THREE MODELS
 \$21.00
 \$17.80
 \$11.80

Bore .900,
 Stroke 31/32.

Complete with coil & condenser

POLK'S PERFECT PITCH
 SHAPED
 PROPELLER



JUST
 SAND IT!

Only 35¢ POST PAID

FOR SMALL JOBS—10"—25¢

Streamlined
 Aluminum
 Tail Wheel
 and Fork.. 50¢



12 Different Photos 10¢
 plus 3¢ postage

Your choice of 30 different sets. Each set consisting of 12 different 2 3/4 x 4 1/2" photos. 10¢ a set plus stamp.

ALBUM 35¢
 Filler No. 1 & No. 2 10¢ ea.



ASSORTMENT

consisting of Album, 2 extra fillers, 72 different photos and 6 Free Gift Coupons \$1.25 P.P.

DEALERS write for discounts.

OUR NEW QUARTERS

at 429 Seventh Avenue, New York are in the heart of Manhattan, Between 33rd and 34th Streets, Opp. Pennsylvania Station.

"THE LEADING HOBBY SHOP IN THE EAST"

2 in 1

POLK'S DE LUXE MIDGET GAS MODEL

2 in 1

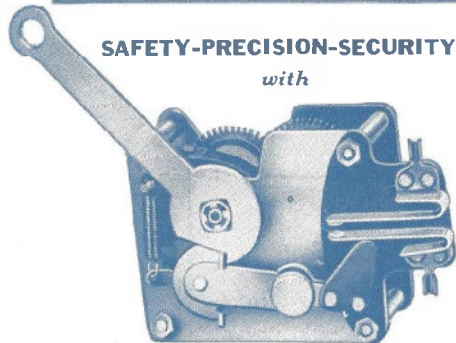

SAFETY-PRECISION-SECURITY

with

POLK'S PRECISION CONTEST TIMER

Weights 1 oz., with built-in snap action switch. 0 to 55 seconds. Postpaid \$1.95

"A Contest Necessity"

MODEL "D"
 ONLY
 \$10.00

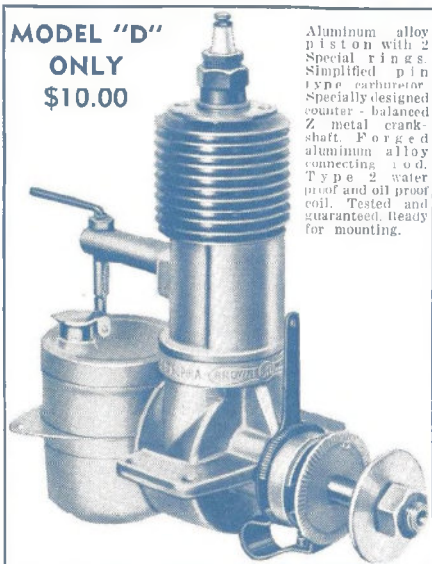

Aluminum alloy piston with 2 special rings. Simplified pin type carburetor. Specially designed counter - balanced Z metal crankshaft. Forged aluminum alloy connecting rod. Type 2 water proof and oil proof coil. Tested and guaranteed ready for mounting.

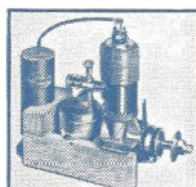

"MODEL B" Hardened steel piston, GROUND and LAPPED to fit. Micrometer type needle valve control. Type 1, Deluxe, waterproof, oil proof and gas proof coil. Completely mounted on skids. Tested and guaranteed. Cadmium plated to a high lustre rust proof finish.

\$21.50

For Small Bore Engines

HUMMING BIRD

BIPLANE OR MONOPLANE

The Humming Bird is the only model designed to fly as a biplane or monoplane • Removable motor unit • Ready cut notched ribs • M & M Pneumatic Wheels • Two colors bamboo paper • Shaped propeller—not a blank • Designed by Frank Ehling • Full size plans • Simple construction • Berryloid liquids • 100 per cent complete Kit only \$3.95 postpaid

The engine which has set the pace in making gas model history is now within the reach of everyone. Lack of money will not prevent you from owning a BROWN JR. ENGINE now. The MODEL D has everything that modellers have come to expect of Brown Jr. Motors—power, speed, stamina, reliability and smooth running.

THE BROWN JR. ENGINE IS WITHIN THE REACH OF EVERYONE. . . Buy yours from POLK'S

The leading Gas Model House in America, who have pioneered in power plane promotion. You get satisfaction and peace of mind when you deal with POLK'S. We show you how to run your engine, advise you on its care and will service and guarantee it. Order yours now.

NEW IMPROVEMENTS

Each engine contains the following improved features: Newly designed "concentrated spark" plug. New extra strength die cast aluminum silicon alloy crank case with high speed bronze bearing. Improved tension spring timer with tungsten contact points. New type, two piece, detachable fuel tank.

WE ALWAYS MAINTAIN A COMPLETE STOCK FOR OUR MANY LEGITIMATE DEALERS

SPECIFICATIONS

Each engine has original specifications. 7/8" Bore, 1" Stroke, 1/5 Horse Power, 1,200 to 10,000 R.P.M. Bare Motor 6 1/2 oz., with coil, tank and condenser 11 1/2 oz., ready to run with gas, 2 batteries, and P.P.P. Propeller 20 1/2 oz.

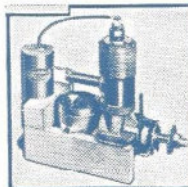

"MODEL C" Aluminum alloy piston with 2 special rings. Simplified pin type carburetor. Type 1 Deluxe coil. Mounted on skids tested and guaranteed. Cadmium plated to a high lustre finish. This engine is just like Model "B" except that the saving in production of the valve and piston is passed on to you.

\$17.00

ALL REPLACEMENT PARTS IN STOCK

We Have In Stock every Gas Engine and Gas Model Kit

POLK'S MODEL CRAFT HOBBIES, INC. (Dept. F) 429 7th Avenue New York (Second Floor) Between 33rd and 34th Streets

SCIENTIFIC MODELS Mighty big values at Mighty Low prices.

COMMODORE deluxe GAS MODEL

This new Scientific gas model has been designed by the well known "Eaglet" gas model designer, Ben Shere-shaw. The "Eaglet" proved so successful that demands were made by hundreds of modelers for a larger model of this type by the same designer. Any inexpensive 1/2 horsepower engine such as the Brown Jr., Ohlsson, Midget, Gwin, Desnymite, Syncro, or any other reliable make motor may be used with success. Kit is



100% complete, including highest quality sheet and strip balsa, finest spring steel wire, all metal fittings, ignition wire. Complete kit, less wheels

Wingspan 6 feet	Airfoil section Gottingen 549	\$6.95 Postpaid
Overall length 50"	Glide Ratio 16 to 1	
Wing Area 5.2 sq. ft.	Rate of Climb	\$7.95 Postpaid
Total weight with motor and ignition mounts . . . 3 1/2 lbs.	Approx. 700 ft. per min.	

Complete kit, including a pair of 3/4" Scientific Pneumatic rubber wheels

The New JITTERBUG Endurance Model

25" Wingspan
Length 20 1/2"
Light Weight
**FLIES OVER
1 MILE
(6,000 FEET)**

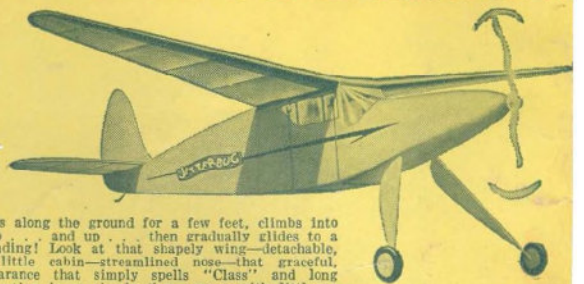

Here's another famous Flying Model originated and designed by Scientific. It speeds along the ground for a few feet, climbs into the sky—spirals up . . . and up . . . then gradually glides to a perfect 3-point landing! Look at that shapely wing—detachable, too!—that classy little cabin—streamlined nose—that graceful, thoroughbred appearance that simply spells "Class" and long flights. The construction is so simple that anyone with little or no past experience can easily build the "Jitterbug" in a few hours. Kit is complete with all materials including streamline wheels and a ready made propeller, full size plans and explicit instructions.

Priced exceptionally low. Complete kit ONLY **50c**
Postpaid or at your dealer.

THE EAGLET for Small Gas Engines

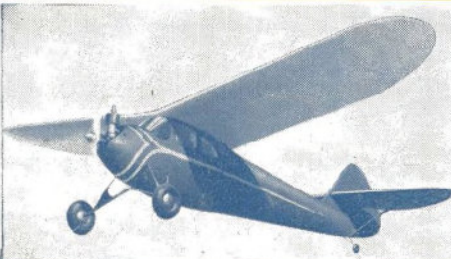

Wingspan 44". Length 32". Flying Weight with Motor 17 ozs. Finest small gas model in existence. Kit is 100% complete.
**DELUXE KIT
\$3.95**
Postpaid or at Dealer. Including M & M Pneumatic Rubber Wheels.

"ORIOLE" CONTEST ENDURANCE MODEL AIRPLANE FLIES 2 to 3 MILES

So simple, even the beginner can complete the model in a day. This Model will clear the ground in a short take-off and climb with amazing speed. Every detail of the "Oriole" conforms with N.A.A. Contest requirements. Kit is 100% complete.
\$1
THE BIGGEST KIT VALUE IN AMERICA TODAY
**50 inch Wingspan
OVERALL LENGTH 34"**
Postpaid or At Your Dealer

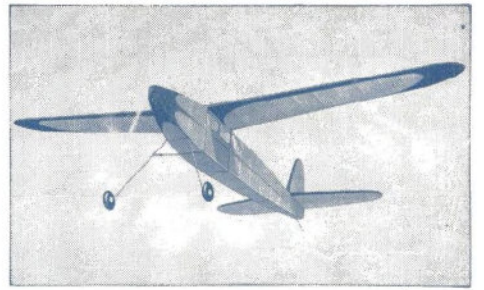

All the Thrills of Gas Model Flight

THEY LOOK, FLY AND SOUND LIKE REAL GAS MODELS

MISS AMERICA

GAS TYPE — RUBBER POWERED MODEL AIRPLANE
40" Wingspan, Weight 4 1/2 ozs., Length 27 1/2". Flies 1 Mile (5200 feet). This is an exact replica of the full size Miss America gas model. Recently a Miss America gas model flew for 46 minutes on a motor run of only 27 seconds, breaking all world's records for so short a motor run. This new small Gas Type Model has all the features of the large model. Can easily be built.
PRICE \$1.95
Postpaid including a pair of M & M pneumatic rubber wheels.

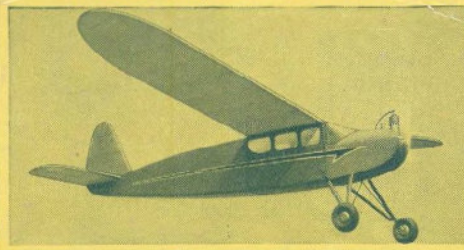

GAS TYPE RUBBER POWERED MODEL AIRPLANE

The "FIREFLY"

Wingspan 36". Length 28". Weight 4 ozs.
The kit is complete. All formers printed on balsa; tru-pitch 10" mahogany propeller; rubber lubricant; brown contest rubber; wire washers; tissue; motor hooks; cement; and all necessary metal for building the ratchet motor-tumb effect. Full size detailed drawings with explicit instructions. A real value. Order your kit now!
\$1.95
Postpaid, including M & M Pneumatic rubber wheels



BUNCH MOTORS

Mighty-Midget Uprt. Asbld. \$9.50
Mighty-Midget Upright Kit 7.85
Mighty-Midget Inv. Asbld. 9.75
Mighty-Midget Inverted Kit 7.85
Gwin-Aero Upright Asbld. 12.00
Gwin-Aero Upright Kit . . . 9.85
Gwin-Aero Inverted Asbld. 12.50
Gwin-Aero Inverted Kit . . . 9.85
Including Prop, 70 Oil and Double Guarantee.



MONOCOUE Guaranteed Flyers

15" Wingspan
Complete Kit with many finished parts only 25c postpaid.



WACO

ROBOT TIMER

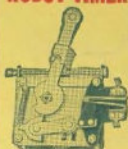

100% Accurate and Guaranteed. Price **\$2.50** Postpaid
Without Automatic Attach. **\$1.95** Postpaid

RED ZEPHYR Gas Model

6 ft. wing, length 56", weight (less motor) 2 1/2 lbs. Complete kit less motor and wheels Postpaid
Price including pneumatic rubber wheels **POSTPAID \$5.95**

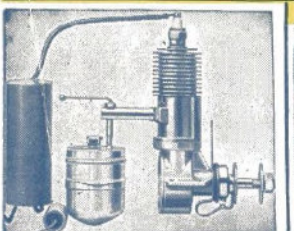

BROWN Jr. \$10 ENGINE-D

Postpaid WITH SCIENTIFIC DOUBLE GUARANTEE



Ready-to-Fly Stick Models **25c** POSTPAID

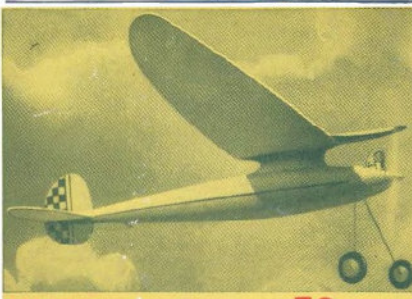

VALKYRIE Special Now - Only **50c** Postpaid
Drastic Reduction. Always sold for \$1.00

"SCIENCE-CRAFT" GUARANTEED KITS

50c each postpaid — 20 inch wingspan



Waco Custom Cabin
Waco F-5
Waco "D"
Grumman Fighter
Curtiss Hell Diver
Mr. Mulligan
Curtiss Hawk P6-E
Howard "Ike"
Beeing Fighter

MONOCOUE-90-A 50c

HUSKY MOTOR

An ideal motor for the Eaglet Gas Model 5/8" bore, 5/8" stroke, weight ready to run only 5 1/2 Ozs. complete. Only **\$12.50** postpaid including propeller, bottle of oil—instruction manual and Scientific's double guarantee.



The FLEA

Gas type, rubber powered. Real motor sound. James Clark's Flea flew 10,000 ft.
Complete Kit Postpaid, including M & M Wheels **\$1.95**

Add 15c postage on orders up to \$1.50, and 10% postage on orders over \$1.50. Orders over \$4.00 are sent postpaid. Kits and motors are sent postpaid.